

US005761485A

# United States Patent [19] Munyan

[11] Patent Number: 5,761,485

[45] Date of Patent: Jun. 2, 1998

[54] PERSONAL ELECTRONIC BOOK SYSTEM

[76] Inventor: Daniel E. Munyan, 805 Mt. Gretna Rd., Elizabethtown, Pa. 17022

[21] Appl. No.: 565,915

[22] Filed: Dec. 1, 1995

[51] Int. Cl.<sup>6</sup> ..... G06F 15/02; G06F 17/40; G09G 1/02

[52] U.S. Cl. .... 395/500; 345/901; 326/8; 395/187.01; 455/411

[58] Field of Search ..... 395/2.69, 500, 395/145, 2.82, 186, 187.01, 188.01, 200.09, 650; 455/89; 379/98, 368, 58; 348/134; 382/14, 56; 345/192, 127, 130, 901; 434/317; 326/8; 364/286.4, 286.5, 949.81, 260; 365/185.04; 462/903; 463/29; 902/4

### [56] References Cited

#### U.S. PATENT DOCUMENTS

3,718,906	2/1973	Lighter .	
4,159,417	6/1979	Rubincam .	
4,545,023	10/1985	Mizzi .	
4,649,499	3/1987	Sutton et al .	
4,682,161	7/1987	Bugg .	
4,763,356	8/1988	Day, Jr. et al. ....	379/368

(List continued on next page.)

#### FOREIGN PATENT DOCUMENTS

2149544	6/1985	United Kingdom .
WO 87/01481	3/1987	WIPO .

#### OTHER PUBLICATIONS

Bryant ("The electronic book—a user's wishlist", IEE Colloquium on 'Human-Computer Interface Design for Multimedia Electronic Books', pp. 9/1-9/3, Jan. 1, 1995).

Miyazawa et al. ("An Electronic Book: APTBook", Human-Computer Interaction—Interact '90, Proceedings of the IFIP TC 13 Third International Conference, 1 Jan. 1990, pp. 513-519).

(List continued on next page.)

Primary Examiner—Emanuel Todd Voeltz  
Assistant Examiner—Phallaka Kik  
Attorney, Agent, or Firm—Earl F. Clifford; Clifford & Clifford Law Firm

### [57] ABSTRACT

The Personal Electronic Book System invention replaces a standard handheld book with an electronic equivalent. The invention is sized and configured to be book size and to open like a book for use. When opened, the user sees two facing page-like touch-sensitive, display screens with black print on white background. Icons represent the electronically stored material, "artwork, audio clips, books, E-mail, faxes, games, magazines, movies, musical compositions, newspapers, photographs, software, video clips, etc.", which are selected by touching the icon. When a book, magazine, newspaper, or the like is selected, its table of contents is displayed and the user can then read page by page or go directly to a particular page by touching the selection listed in the table of contents. Closing the Personal Electronic Book automatically shuts down the device. Touching a page number before closing the Personal Electronic Book inserts a bookmark so that when the Personal Electronic Book is re-opened, the user is returned to the same page. New printed or multimedia material can be downloaded from an remote server, that is, "a bookstore," and old material, books read, etc., can be deleted to make room for the new material.

21 Claims, 2 Drawing Sheets

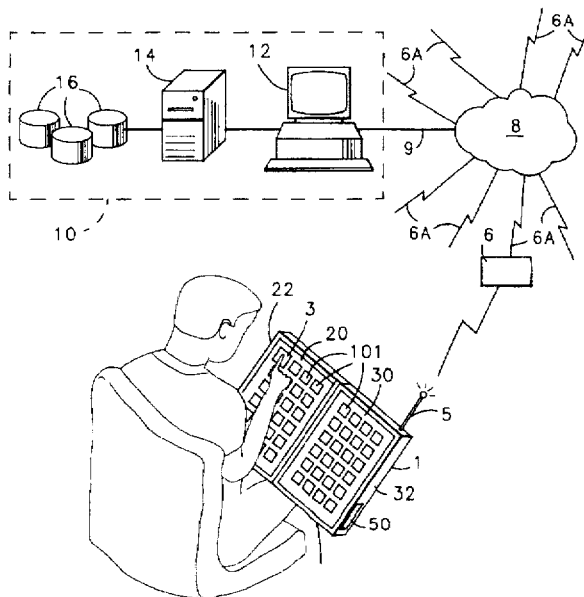

## U.S. PATENT DOCUMENTS

4,855,725	8/1989	Fernandez .	
4,918,632	4/1990	York .	
5,031,119	7/1991	Dulaney et al. .	
5,105,468	4/1992	Guyon et al. ....	382/14
5,109,354	4/1992	Yamashita et al. .	
5,146,552	9/1992	Cassorla et al. ....	395/145
5,267,334	11/1993	Normille et al. ....	382/56
5,291,598	3/1994	Grundy .....	395/650
5,333,152	7/1994	Wilber .....	379/98
5,339,091	8/1994	Yamazaki et al. .	
5,379,057	1/1995	Clough et al. .	
5,410,326	4/1995	Goldstein .....	348/134
5,465,401	11/1995	Thompson .....	455/89
5,500,991	3/1996	Luther .....	395/2.69
5,561,705	10/1996	Allard et al. ....	379/58

## OTHER PUBLICATIONS

Keates et al. ("Copyright protection of artistic materials in electronic form: the CITED approach", *Information Services & Use*, vol. 13, No. 4, Jan. 1993, pp. 389-398).

Brownrigg et al. ("An Electronic Library Communications Format: A Definition and Development Proposal for MARC III", *Library Hi Tech*, vol. 8, No. 3, Jan. 1990, pp. 21-26).

Bryant ("The paperless book", *IEE Review*, vol. 41, Issue 6, 16 Nov. 1995, pp. 245-247).

Gray ("Evolution of Data Management", *Computer Magazine*, vol. 29, Issue 10, Oct. 1996, pp. 38-46).

Pobiak ("Adjustable access electronic books", *IEEE Comput. Soc. Press. Proceedings of the Johns Hopkins National Search for Computing Applications to Assist Persons with Disabilities*, 1 Feb. 1992, pp. 90-94).

Carey et al. ("Towards heterogeneous multimedia information systems: the Garlic approach", *IEEE Comput. Soc. Press. Proceedings RIDE-DOM '95: Fifth International Workshop on Research Issues in Data Engineering-Distributed Object Management*, 6 Mar. 1995).

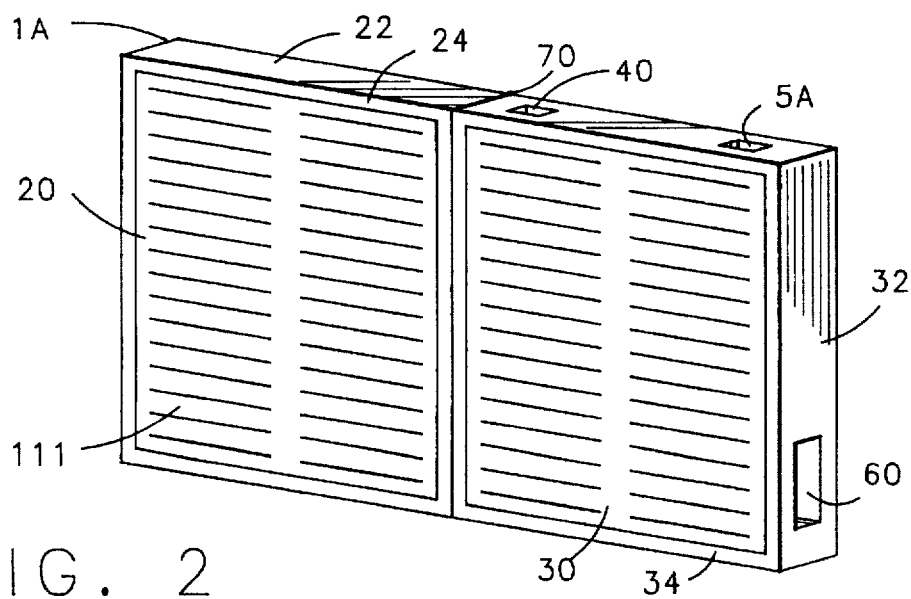
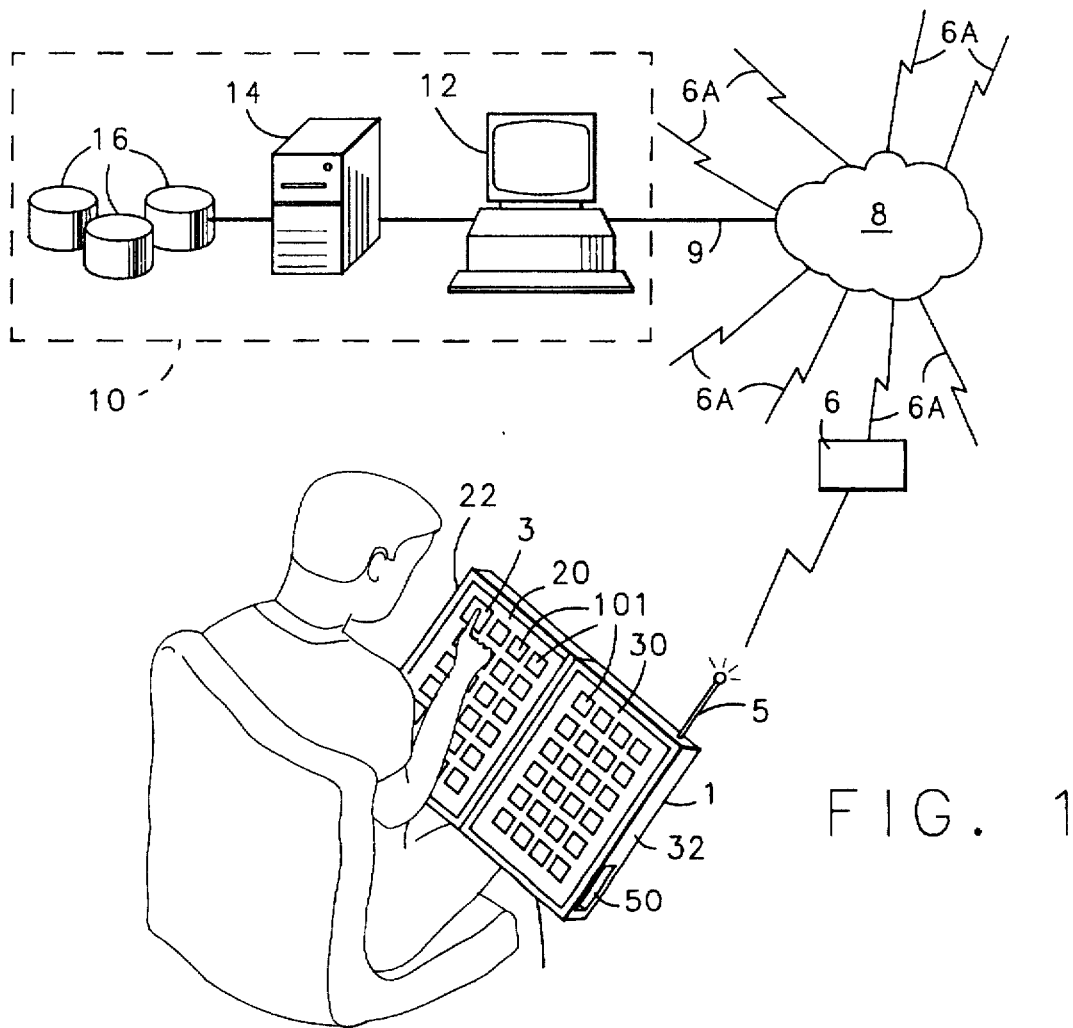

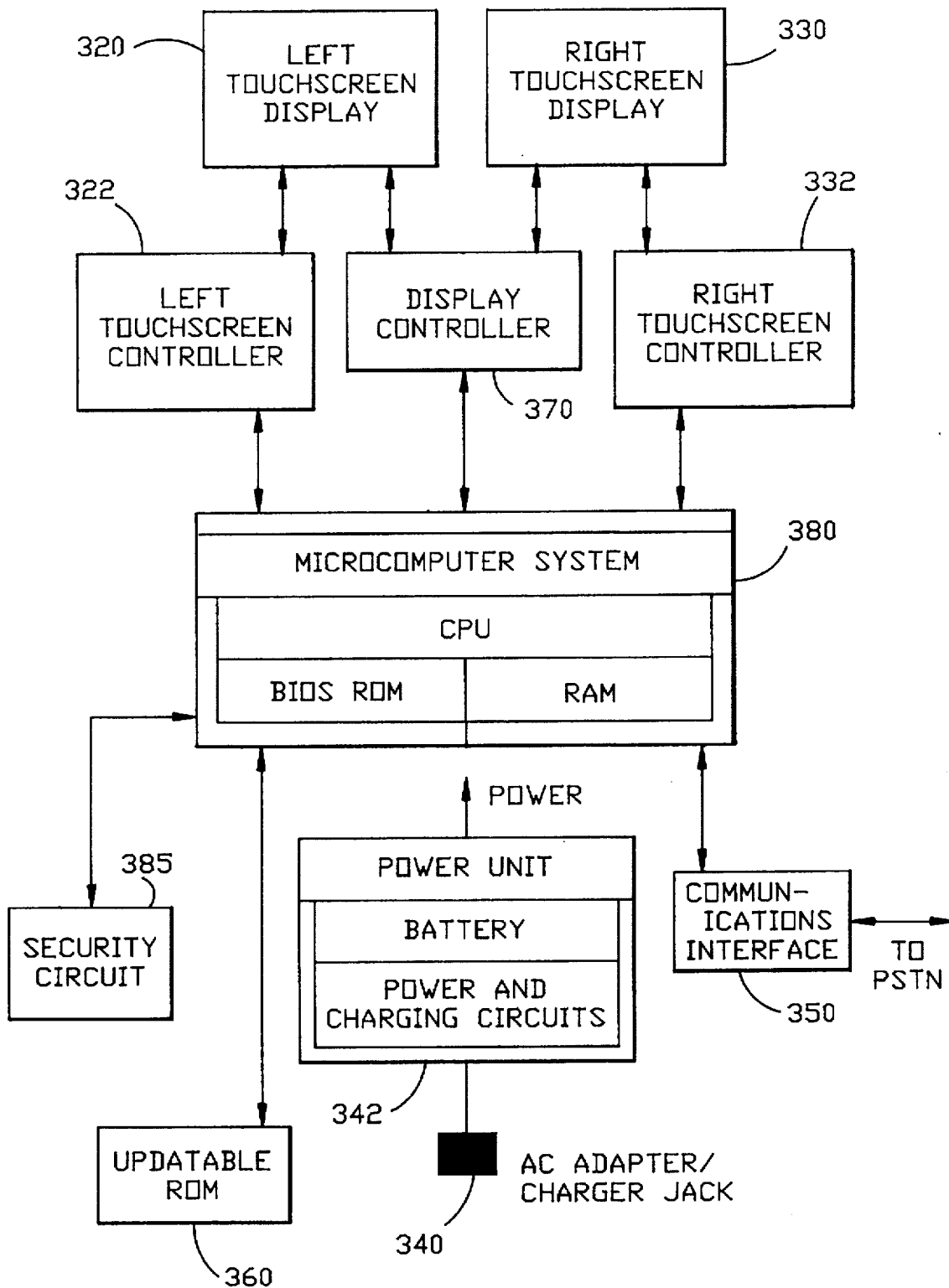

FIG. 3

PERSONAL ELECTRONIC BOOK SYSTEM

BACKGROUND OF THE INVENTION

1. Field of the Invention

The present invention relates to information and multi-media storage and display systems and specifically to paperless books, personal electronic books, personal electronic communicators and readers, personal electronic message communicators, personal electronic facsimile communicators, on-line computer database communicators, and downloadable computer database products such as artwork, audio clips, books, E-mail, faxes, games, magazines, movies, musical compositions, newspapers, photographs, software and video clips.

2. Description of the Prior Art

Vast amounts of printed material are widely distributed in the form of printed books, magazines and newspapers. These traditional media are printed on paper with a page printed on each side of the paper so that when reading a book, magazine or newspaper, two pages of printed material are exposed to the reader. These printed materials consume vast quantities of paper and also shipping resources to transport them to bookstores or newsstands for sale to the ultimate consumer, to libraries or to warehouses for storage. In recent years, virtually all commercially printed media are printed from computer-based databases and yet these same databases are only slowly becoming available to users of personal computers (PC). Even with the availability of book-like material displayed in page format on the PC, consumers have shown a very low acceptance level to reading from a computer screen. Readers want to hold and cradle the item they are reading, view entire pages at once, and look down at their reading material.

Newspapers and magazines spend about 100 million dollars a year producing electronic editions of their publications. More than 120 newspapers currently offer electronic editions. Dozens of magazines covering a diversity of subjects are available in electronic editions. The Wall Street Journal reported that an April, 1995 survey of 650 newspapers indicated that 12 percent of these are already offering on-line electronic editions and that 40 more newspapers expect to offer electronic editions by the end of 1995. A major deficiency of electronic editions of newspapers and magazines is that these editions typically bear little resemblance to the printed publications especially in terms of graphics, page layout and typography.

With the accessibility and ready availability of the PC, accessing information stored in computer databases and in multimedia formats has transcended the computer mainframe and has been popularized in various media now available to the PC. As yet, this information and multimedia explosion has failed to deliver a personal, dedicated electronic device that is as easy to use or even as desirable to use as the common book, printed on paper and bound in a soft or hard cover. The present invention provides a personal, portable electronic book that overcomes these deficiencies.

The prior art which may be relevant to this invention is described hereinafter.

U.S. Pat. No. 3,718,906 to Lightner discloses a method and apparatus for a computer controlled host to transmit customer selected sound (or video) recordings stored on constantly running endless master tapes over AT&T's picturephone telephone lines to remote vending machines where the sound recordings are recorded onto cassettes and

into a remote computer-controlled storage facility and ordering the transmission of stored information such as sound or video recordings to a remote device where the information is duplicated onto a tape cassette and paid for by the customer.

U.S. Pat. No. 4,159,417 to Rubincam discloses a portable, battery powered electronic viewer that reads and displays data stored in a holographic memory card. The memory can be page oriented so that each hologram represents a page in a book and the entire book can be stored on one card. An alternative embodiment provides a book-sized container hinged like a book so that 2 opposing displays can be read in a manner similar to the reading of a book. The device incorporates controls for controlling pagination, for adjusting the speed of leafing through the book and for displaying and entering page numbers. This disclosure describes facing displays mounted in a hinged book-sized device with plug-in memory card storage for a single book and functions that provide page control.

U.S. Pat. No. 4,545,023 to Mizzi discloses a handheld, battery-powered computer comprising various electronic cards and a flat touchscreen. The touchscreen eliminates the need for a keyboard or other input keypads. The screen can display alphanumeric characters and graphics. Any area touched on the screen is identified by its coordinates. The device can be connected to a remote host computer via an acoustic coupler and a telephone line. The device can be adapted for particular uses such as hand-writing recognition or TV or radio receiving by plugging in special purpose electronic cards. This disclosure describes a battery-powered, handheld computer that uses a large, flat touchscreen display to replace a mechanical keyboard and that has the facilities to communicate with a remote host over telephone lines.

U.S. Pat. No. 4,649,499 to Sutton et al. discloses computer programs designed to emulate a three dimensional object such as a rotary card file or a hand calculator on a computer touchscreen. Functions are performed by touching appropriate symbols on the touchscreen, for example, a knob to rotate the cards, a tab label to select and view a card, plus softkeys to perform other functions on the cards. An emulation that puts up a functional calculator touchscreen display is also disclosed. This disclosure describes the interaction between a touchscreen and the operation of a computer and software to present a display of information with softkey areas that are used to provide user control of the associated information or function.

U.S. Pat. No. 4,682,161 to Bugg discloses a video display terminal connected via a modem over a telephone line to a remote source for the purpose of acquiring and transmitting information. This disclosure describes the logic circuits used to transfer digital codes to the terminal so that the data can be displayed on a raster scan display device in either normal or enlarged character size. This disclosure describes communicating over a telephone line via modem and transferring data to be displayed on a screen.

U.S. Pat. No. 4,855,725 to Fernandez discloses a simulated book that uses a battery-powered microprocessor with ROM for the program and RAM storage for data and a large LCD screen to display up to 2 pages of information transmitted from a CD-ROM equipped PC over an attached infrared transceiver to a transceiver incorporated into the simulated book. The book uses a touchscreen to display the data and to control paging through the material. The device automatically requests additional pages of information to be

# Explore Litigation Insights

Docket Alarm provides insights to develop a more informed litigation strategy and the peace of mind of knowing you're on top of things.

## Real-Time Litigation Alerts



Keep your litigation team up-to-date with **real-time alerts** and advanced team management tools built for the enterprise, all while greatly reducing PACER spend.

Our comprehensive service means we can handle Federal, State, and Administrative courts across the country.

## Advanced Docket Research



With over 230 million records, Docket Alarm's cloud-native docket research platform finds what other services can't. Coverage includes Federal, State, plus PTAB, TTAB, ITC and NLRB decisions, all in one place.

Identify arguments that have been successful in the past with full text, pinpoint searching. Link to case law cited within any court document via Fastcase.

## Analytics At Your Fingertips



Learn what happened the last time a particular judge, opposing counsel or company faced cases similar to yours.

Advanced out-of-the-box PTAB and TTAB analytics are always at your fingertips.

## API

Docket Alarm offers a powerful API (application programming interface) to developers that want to integrate case filings into their apps.

## LAW FIRMS

Build custom dashboards for your attorneys and clients with live data direct from the court.

Automate many repetitive legal tasks like conflict checks, document management, and marketing.

## FINANCIAL INSTITUTIONS

Litigation and bankruptcy checks for companies and debtors.

## E-DISCOVERY AND LEGAL VENDORS

Sync your system to PACER to automate legal marketing.