

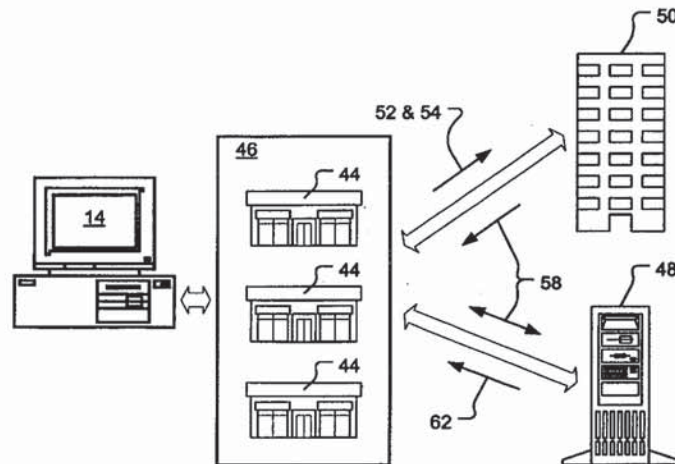

INTERNATIONAL APPLICATION PUBLISHED UNDER THE PATENT COOPERATION TREATY (PCT)

<p>(51) International Patent Classification ⁶ : G06F 7/06, 17/60, H04R 9/00, H04L 9/00</p>	<p>A1</p>	<p>(11) International Publication Number: WO 99/13398 (43) International Publication Date: 18 March 1999 (18.03.99)</p>
<p>(21) International Application Number: PCT/US98/18948 (22) International Filing Date: 11 September 1998 (11.09.98) (30) Priority Data: 60/058,623 11 September 1997 (11.09.97) US (71) Applicant (for all designated States except US): FAULT LINE TECHNOLOGY, INC. [US/US]; Suite 100 A, 380 El Pueblo Drive, Scotts Valley, CA 95066 (US). (72) Inventors; and (75) Inventors/Applicants (for US only): PETERSON, Harold, L. [US/US]; 17300 Debbie Road, Los Gatos, CA 95033 (US). WILLIAMS, James, B. [US/US]; 11345 Empire Grade Road, Santa Cruz, CA 95060 (US). (74) Agents: HUGHES, Michael, J. et al.; Intellectual Property Law Office of Michael J. Hughes, Suite 295, 1171 Homestead Road, Santa Clara, CA 95050 (US).</p>		<p>(81) Designated States: BR, CA, CN, IL, JP, US, European patent (AT, BE, CH, CY, DE, DK, ES, FI, FR, GB, GR, IE, IT, LU, MC, NL, PT, SE). Published <i>With international search report. Before the expiration of the time limit for amending the claims and to be republished in the event of the receipt of amendments.</i></p>

(54) Title: DIGITAL CONTENT VENDING, DELIVERY, AND MAINTENANCE SYSTEM



(57) Abstract

A digital content vending machine, DCVM (10), in which a client (12) on a personal computer, PC (14), contains an infrastructure (16) and an inventory (18). The infrastructure (16) and inventory (18) may both be stored in a hard drive (20), or the inventory (18) may instead be stored on a removable media (24), such as a CD (16), DVD (28), or tape (30). The infrastructure (16) presents a graphical user interface on the client (12) which metaphorically resembles a village (46) containing a plurality of stores (44) operated by vendors (42). Customers (40) shop in the stores (44) by selecting assets (22), constituting the inventory (18), and sending money (52) and an identifier (54) to a clearing house (50) via a communications system such as telephone (118), private network (120), or the Internet (122). The clearing house (50) returns a key (58) used to at least partially remove a digital wrapper (60) protecting the asset (22) from unauthorized use. A master server (48) may also be provided to update the infrastructure (16) and inventory (18), and to provide additional keys (58) used to remove the digital wrappers (60).

FOR THE PURPOSES OF INFORMATION ONLY

Codes used to identify States party to the PCT on the front pages of pamphlets publishing international applications under the PCT.

AL	Albania	ES	Spain	LS	Lesotho	SI	Slovenia
AM	Armenia	FI	Finland	LT	Lithuania	SK	Slovakia
AT	Austria	FR	France	LU	Luxembourg	SN	Senegal
AU	Australia	GA	Gabon	LV	Latvia	SZ	Swaziland
AZ	Azerbaijan	GB	United Kingdom	MC	Monaco	TD	Chad
BA	Bosnia and Herzegovina	GE	Georgia	MD	Republic of Moldova	TG	Togo
BB	Barbados	GH	Ghana	MG	Madagascar	TJ	Tajikistan
BE	Belgium	GN	Guinea	MK	The former Yugoslav Republic of Macedonia	TM	Turkmenistan
BF	Burkina Faso	GR	Greece	ML	Mali	TR	Turkey
BG	Bulgaria	HU	Hungary	MN	Mongolia	TT	Trinidad and Tobago
BJ	Benin	IE	Ireland	MR	Mauritania	UA	Ukraine
BR	Brazil	IL	Israel	MW	Malawi	UG	Uganda
BY	Belarus	IS	Iceland	MX	Mexico	US	United States of America
CA	Canada	IT	Italy	NE	Niger	UZ	Uzbekistan
CF	Central African Republic	JP	Japan	NL	Netherlands	VN	Viet Nam
CG	Congo	KE	Kenya	NO	Norway	YU	Yugoslavia
CH	Switzerland	KG	Kyrgyzstan	NZ	New Zealand	ZW	Zimbabwe
CI	Côte d'Ivoire	KP	Democratic People's Republic of Korea	PL	Poland		
CM	Cameroon	KR	Republic of Korea	PT	Portugal		
CN	China	KZ	Kazakstan	RO	Romania		
CU	Cuba	LC	Saint Lucia	RU	Russian Federation		
CZ	Czech Republic	LI	Liechtenstein	SD	Sudan		
DE	Germany	LK	Sri Lanka	SE	Sweden		
DK	Denmark	LR	Liberia	SG	Singapore		
EE	Estonia						

DIGITAL CONTENT VENDING, DELIVERY, AND MAINTENANCE SYSTEM

This application claims benefit of U.S. provisional application serial number 60/058,623, filed September 11, 1997.

5

TECHNICAL FIELD

The present invention relates generally to the marketing functions of vending and delivery of digital content and services related thereto, and more particularly to interactive computer network systems for such marketing.

10

BACKGROUND ART

Today we are seeing a merging of many products and services into digital formats. Some typical examples of such digital products are computer software; audio content, like music or audio-books; and audio-visual content, like videos and movies. For present purposes, the salient feature of such digital products is that they can often be treated as mere bags-of-bits (BOB's), with the underlying nature of the products ignored during most handling after creation and before use.

15

Somewhat less widely appreciated is that many services are now also digital to a considerable extent. For example, computer users today let applets run tests and communicate the results to providers for obtaining installation, upgrade, and problem diagnosis of operating system and applications software; computer game players send each other hints via e-mail; and Internet "telephone" and "radio" are emerging as replacements for specialized telephone and broadcast systems. Thus, often to a considerable extent services today can be reduced to digital communications, and can then also be treated as BOB's, in a somewhat more dynamic sense.

20

For more stable forms of such digital content, such as the products noted above, it has long been appreciated that the particular storage media used has become largely irrelevant. Tape, disk, and drum media are all common, as are physical, magnetic, and optical means of impressing digital content into them. Similarly, for digital services the channels of communication used have similarly become largely irrelevant. Electrical current through wires, light through fibers, and radiation through space are all common, and substantially interchangeable communications channels.

25

Of relatively recent advent are communications networks, particularly including

public networks like the Internet. Although access to such networks is still far from universal, such networks are increasing the trend towards the irrelevance of the underlying media used to store digital products and the medium used to communicate digital services. Accordingly, in the following discussion the collective term “digital content” is used.

5 Because networks are overwhelmingly computerized, and thus those most familiar already with computers can be expected to most easily appreciate and readily adopt network storage and delivery of digital content, examples in the context of personal computers will be primarily used (personal computer: "PC"; used here in the broad sense, because even most computers in business today are actually termed PC's). It should, however, at all times also
10 be appreciated that the principles being discussed are valid for and extendable to other contexts.

Turning now to an example of how the potential of digital content is not adequately being employed, new PC's today are usually purchased with some specific task in mind, such as word-processing. However, often the customer also wants to try out new PC hardware and
15 software capabilities, much like the child in us all likes to immediately play with a new toy. Further, when a consumer purchases a new PC he or she usually also wants to employ it for such intended and experimental tasks almost immediately. It thus is not surprising that studies show that new PC owners are twice as likely to purchase software, as compared to ones who have owned their computers for longer than three months.

20 Various vehicles for delivery of software for new PC's exist. For example, it can be obtained at the same time as a new PC, or by returning to the store for later purchase. Further, obtaining the software at the same time as the PC can be achieved as a collateral purchase, or it can be obtained as "bundled" software coming with the PC. Unfortunately, there are a number of problems with these methods of delivery.

25 The collateral purchase of software usually occurs only when the consumer knows exactly what he or she wants, or when the price is within the consumer's impulse purchase price range (i.e., relatively low in price). There are various reasons for this, but some typical ones include the divide and conquer approach to getting a complex system working (including even so-called turn-key PC's today), and the palatability of separating hardware
30 and software costs (which are substantial, particularly together).

In theory, the bundled approach to software delivery seems quite desirable. The consumer gets pre-installed working software, and economy of scale keeps the price for this low. Unfortunately, theory and reality do not mesh well here, and the desire of PC

manufacturers today is to reduce the amount of bundled software. In surveys the reasons cited for this include cost (approx. \$20 per system; which is substantial in the low margin competitive field of hardware sales), lack of quality in the software offerings (so-called "shovelware"), and general customer dissatisfaction. In fact, one top-ten PC manufacturer has
5 found that over 20% of its customer survey respondents sent their PC's back because the bundled software "didn't work."

Thus, later purchase of software (i.e., post initial PC sale) remains the overwhelming means by which consumers today obtain software for their PC's, but even this approach has problems which are legend. Obviously there is the awkwardness of a second purchase, or
10 purchases, with the attendant issues of what is now current, where it is in stock, and whether the stores are open. There are also heightened compatibility problems, since the consumer is now back in the store and the PC is now at home or in the office. And there are customer service issues. Even if the consumer returns to the very same store where he or she bought the PC, and perhaps even the very same clerk, he or she is now treated as if the present software
15 purchase is the total extent of the commercial relationship.

However, as noted above, there are emerging new trends in marketing itself. Computer software is one of the leading commodities which has become digital content. For example, less than 2% of all software sales were recorded in electronic distribution channels in 1996, but that figure is expected to increase rapidly. Studies now show that 1/3 of software
20 publishers expect 1/2 of their sales volume to be delivered electronically within the next 12-18 months.

Unfortunately, today electronic distribution of computer software remains merely another form of "later purchase" of software. It does nothing about, and in some cases even exacerbates, the existing technical issues of installation, configuration, and compatibility.
25 And it introduces a plethora of new commercial issues, such as consumer trust in the mechanisms used for transactions, protections for the intellectual property in manufacturer's software products, and legal mechanisms to address breakdowns in these.

Accordingly, from the above it follows that what is today needed is a new mechanism for the marketing of computer software and services. And, by implication, as additional forms
30 of digital content become common as well, such new marketing mechanisms should be extendable to them as well.

Explore Litigation Insights

Docket Alarm provides insights to develop a more informed litigation strategy and the peace of mind of knowing you're on top of things.

Real-Time Litigation Alerts



Keep your litigation team up-to-date with **real-time alerts** and advanced team management tools built for the enterprise, all while greatly reducing PACER spend.

Our comprehensive service means we can handle Federal, State, and Administrative courts across the country.

Advanced Docket Research



With over 230 million records, Docket Alarm's cloud-native docket research platform finds what other services can't. Coverage includes Federal, State, plus PTAB, TTAB, ITC and NLRB decisions, all in one place.

Identify arguments that have been successful in the past with full text, pinpoint searching. Link to case law cited within any court document via Fastcase.

Analytics At Your Fingertips



Learn what happened the last time a particular judge, opposing counsel or company faced cases similar to yours.

Advanced out-of-the-box PTAB and TTAB analytics are always at your fingertips.

API

Docket Alarm offers a powerful API (application programming interface) to developers that want to integrate case filings into their apps.

LAW FIRMS

Build custom dashboards for your attorneys and clients with live data direct from the court.

Automate many repetitive legal tasks like conflict checks, document management, and marketing.

FINANCIAL INSTITUTIONS

Litigation and bankruptcy checks for companies and debtors.

E-DISCOVERY AND LEGAL VENDORS

Sync your system to PACER to automate legal marketing.