



US005940805A

# United States Patent [19]

[11] Patent Number: **5,940,805**

**Kopp**

[45] Date of Patent: **\*Aug. 17, 1999**

[54] **METHOD OF SELLING DATA RECORDS AS WELL AS VENDING APPARATUS, MEMORY DEVICE, CHIP CARD, AND SYSTEM FOR SELLING TELECOMMUNICATIONS SOFTWARE**

3909323	9/1990	Germany	.....	G07F	17/00
3928107	2/1991	Germany	.....	G06F	15/21
3809795	1/1992	Germany	.....	G06F	12/14
3927236	8/1992	Germany	.....	G07F	17/00
9401027	9/1994	Germany	.....	G07F	17/00
9410717	10/1994	Germany	.....	G07F	11/00
4314900	11/1994	Germany	.....	G11B	33/02
9401027	11/1994	Germany	.....	G07F	17/00
4339438	10/1995	Germany	.....	G06F	13/38
5-089360	4/1993	Japan	.....	G07F	17/00

[75] Inventor: **Dieter Kopp**, Hemmingen, Germany

[73] Assignee: **Alcatel N.V.**, Rijswijk, Netherlands

[\*] Notice: This patent issued on a continued prosecution application filed under 37 CFR 1.53(d), and is subject to the twenty year patent term provisions of 35 U.S.C. 154(a)(2).

### OTHER PUBLICATIONS

S.L. Millin, "Object Technologies on-line", Software Industry Report, V.26, n.15, p. 5(2), Aug. 8, 1994.  
 "Connect develops electronic marketplace system for OMG", Electronic Marketplace Report, V. 8, n. 17, p. 7(2), Sep. 6, 1994.  
 John Slitz, "USA: Objects get on-line with the information brokerage", Businesswire. Jul. 25, 1994.  
 Charlotte Dunlap, "Connect offers online link", Computer Reseller News, n. 597, pp: 58, Sep. 26, 1994.  
 "How Much is That Object in the Window?" on p. 54 of the Aug. 22, 1994 issue of "Business Week".

[21] Appl. No.: **08/571,526**

[22] Filed: **Dec. 13, 1995**

### [30] Foreign Application Priority Data

Dec. 22, 1994 [DE] Germany ..... 44 45 847

[51] Int. Cl.<sup>6</sup> ..... **G06F 15/44**; G06F 13/00

[52] U.S. Cl. .... **705/26**; 364/479.07; 364/479.05; 364/479.03; 364/478.01; 331/176; 331/158; 235/301; 235/379; 235/380

[58] Field of Search ..... 364/900, 479, 364/401; 380/23; 235/380; 379/40

*Primary Examiner*—Allen R. MacDonald

*Assistant Examiner*—Pedro R. Kanof

*Attorney, Agent, or Firm*—Ware, Fressola, Van der Sluys & Adolphson LLP

### [57] ABSTRACT

A vending apparatus (AUT) is used to sell data records. The vending apparatus comprises a payment device (PAY), a control device (CONTR), a device for limiting the extent of utilization (RESTR), and an interface device (INTER1). The interface device (INTER1) sends a release signal to the control device (CONTR), when a suitable memory device (MEM2) is coupled to it in such a way, that a data transfer becomes possible. The device for limiting the extent of utilization (RESTR) only permits the storage of data records in the memory device (MEM) to a predetermined extent. The control device (CONTR) causes the transmission of at least one to be sold data record to the device for limiting the extent of utilization (RESTR), if it receives a release signal from the payment device (PAY) and the interface device (INTER1).

### [56] References Cited

#### U.S. PATENT DOCUMENTS

3,679,842	7/1972	Ahy	.....	179/100.2
4,593,376	6/1986	Volk	.....	364/900
4,597,058	6/1986	Izumi et al.	.....	364/900

(List continued on next page.)

#### FOREIGN PATENT DOCUMENTS

0122040	10/1984	European Pat. Off.	.....	G07F	17/16
0191162	8/1986	European Pat. Off.	.....	G06F	12/14
0409701	1/1991	European Pat. Off.	.....	G07F	7/10
0535630	4/1993	European Pat. Off.	.....	G07F	17/06
3412663	10/1985	Germany	.....	G11C	7/00
3700504	11/1989	Germany	.....	G06F	11/08
3906349	9/1990	Germany	.....	G06K	19/073

**13 Claims, 2 Drawing Sheets**

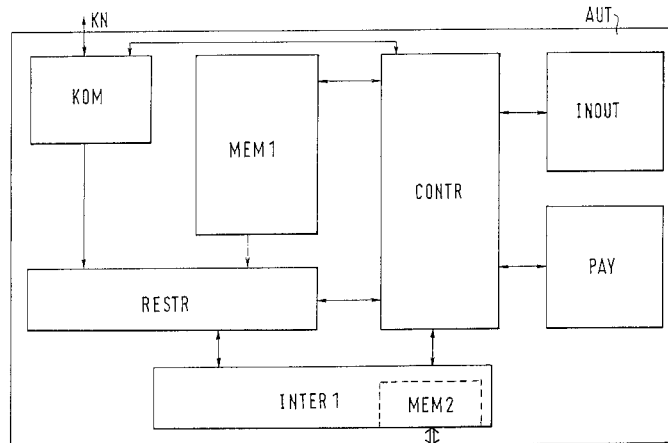

U.S. PATENT DOCUMENTS

4,614,861	9/1986	Pavlov et al. ....	235/380	4,949,257	8/1990	Orbach .....	364/401
4,631,357	12/1986	Grunig .....	379/40	5,027,398	6/1991	Miyoshi .....	380/4
4,650,978	3/1987	Hudson et al. ....	235/380	5,162,989	11/1992	Matsuda .....	364/401
4,674,055	6/1987	Ogaki et al. ....	364/497	5,193,114	3/1993	Moseley .....	380/23
4,740,890	4/1988	William .....	364/234	5,265,075	11/1993	Bergeron et al. ....	369/25
4,787,050	11/1988	Suzuki .....	364/479	5,561,604	10/1996	Buckley et al. ....	364/479.05

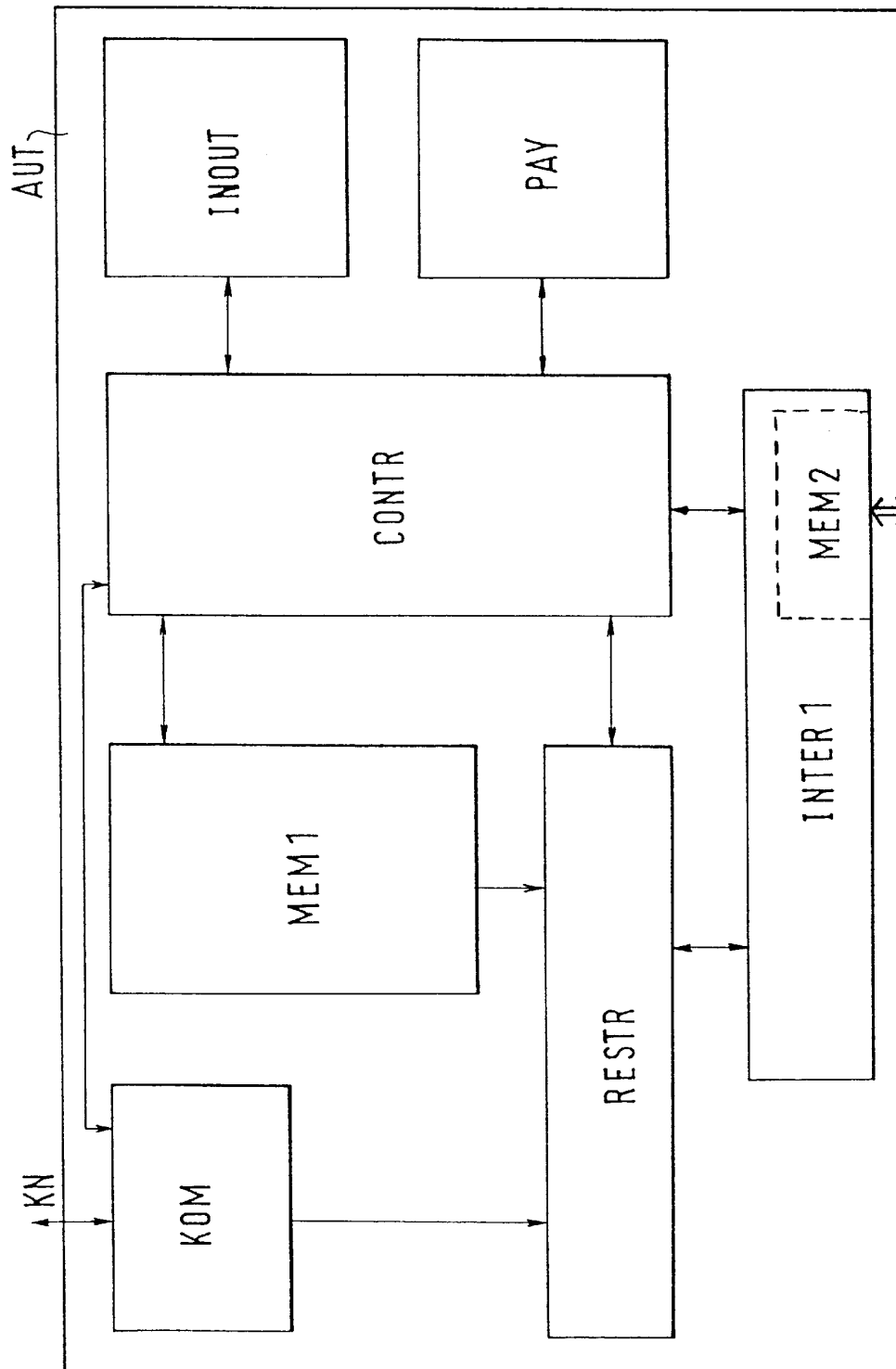

Fig. 1

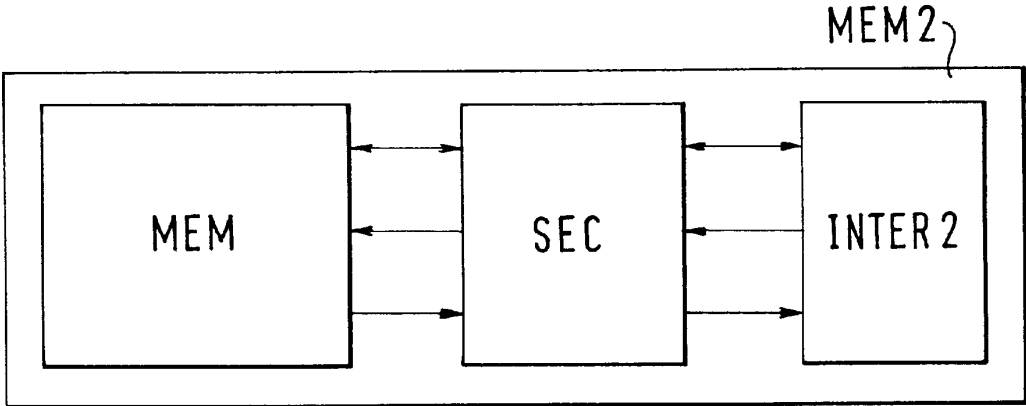

Fig. 2

1

**METHOD OF SELLING DATA RECORDS AS  
WELL AS VENDING APPARATUS, MEMORY  
DEVICE, CHIP CARD, AND SYSTEM FOR  
SELLING TELECOMMUNICATIONS  
SOFTWARE**

**TECHNICAL FIELD**

The invention concerns a method for selling data records by means of a vending apparatus, a vending apparatus, a memory device, a chip card and a selling system for telecommunications software.

**BACKGROUND OF THE INVENTION**

The invention starts with several known software vending methods. As a rule, software programs are acquired by the user in a store, where he purchases a data carrier (e.g. floppy diskettes(s) and CDROM(s)) with the software program stored thereon.

This method has the disadvantage that the buyer must purchase a data carrier in addition to the software program, and could possibly spend much time for the transaction.

Furthermore, software selling systems are known, whereby software programs are electronically sent to the buyers. Such a selling system is described for example in the article "How Much is That Object In The Window?", on page 54 of the Aug. 22, 1994 issue of "Business Week". This selling system offers the buyers software programs from different manufacturers via an electronic communications system, which can be purchased by them through this system. One disadvantage of such a system is that the buyer must have a suitable terminal available for this electronic communications system.

The invention further starts with a vending apparatus for software as described in the German Patent G 94 01 027. This vending apparatus is used to sell public domain or shareware software programs. It contains a hard disk or a CD-ROM drive, a disk drive, a simplified keyboard and a coin checking device. A software program is selected with the keyboard and copied by means of the hard disk or CD-ROM drive to a disk which the buyer has inserted into the disk drive, after the coin checker has verified the insertion of a specified amount of money.

**SUMMARY OF THE INVENTION**

The invention has the task of making data records available for a fee. The task is fulfilled by a method of selling data records for consumer facilities by means of a vending apparatus, comprising the steps of checking whether a suitable memory device has been coupled to an interface device of the vending apparatus in such a way that a data transfer is possible; checking whether a pay device is providing a release signal; and, if these two conditions are fulfilled, storing at least one data record to be sold on the memory device such that the stored data record is released for use only to a predetermined extent.

It also has the task of vending apparatus for selling data records, comprising a pay device for receipt of a payment from a user and for generating a release signal if a payment is made; a control device in cooperative engagement with the pay device; a use-restricting device in cooperative engagement with the control device; and an interface device for coupling memory devices to the vending apparatus, the interface device in cooperative engagement with the use-restricting device, the control device and the pay device so as to send a release signal to the control device when a

2

suitable memory device has been coupled to the interface device in such a way that a data transfer is possible, the use-restricting device for causing data records to be stored on the memory device so that a stored data record will be released only to a predetermined extent, and the control device initiating the transfer of at least one data record to be sold to the use-restricting device when receiving a release signal from the pay device and the interface device.

It further has the task of a memory device for buying data records, comprising an interface device for coupling the memory device to a vending apparatus; a memory within the memory device for storing data records received via the interface device; and a security device in cooperative engagement with the interface device and the memory and which releases the data records stored in the memory for use only to a predetermined extent.

A further task of the device is a chip card for use in consumer facilities, said chip card having a memory device comprising an interface device for coupling the chip card to vending apparatuses and consumer facilities; a memory within the memory device for storing data records received via the interface device; and a security device in cooperative engagement with the interface device and the memory and which releases the data records stored in the memory for use only to a predetermined extent.

A still further task of the invention is a system for selling telecommunications software, comprising a plurality of chip cards each provided with a memory device; a plurality of vending apparatuses for transferring programs onto the chip cards; and a plurality of telecommunication devices each provided with an interface device for coupling chip cards thereto and designed to be controlled in accordance with programs stored on a chip card coupled to the telecommunication device, each of the vending apparatuses comprising a pay device for receipt of a payment from a user and for generating a release signal if a payment is made, a control device in cooperative engagement with the pay device, a use-restricting device in cooperative engagement with the control device, and an interface device for coupling chip cards to the vending apparatus, the interface device in cooperative engagement with the use-restricting device, the control device and the pay device so as to send a release signal to the control device when a suitable chip card has been coupled to the interface device in such a way that a data transfer is possible, the use-restricting device for causing data records to be stored on the chip card so that a stored data record is released only to a predetermined extent, and the control device initiating the transfer of at least one data record to be sold to the use-restricting device when receiving a release signal from the pay device and the interface device.

The basic idea of the invention is to store in this manner a data record on a suitable memory device through a vending apparatus, so that the data record is only released for utilization to a predetermined extent. In this way the buyer no longer acquires a data carrier with a physical copy of the data record, but rather a data record with a specified, limited possibility of utilization.

In this sense a data record comprises software programs or data for software programs, such as for example encyclopedias, but also video and audio recordings, etc.

The invention has the advantage that the data records sold in this manner become a consumable commodity. This makes it possible for a buyer to specify the extent of utilization he wants, to pay only for that and to receive a data record which is only released to this extent of utilization.

It is also an advantage here that by using a vending apparatus, the extent of utilization can be individually speci-

# Explore Litigation Insights

Docket Alarm provides insights to develop a more informed litigation strategy and the peace of mind of knowing you're on top of things.

## Real-Time Litigation Alerts



Keep your litigation team up-to-date with **real-time alerts** and advanced team management tools built for the enterprise, all while greatly reducing PACER spend.

Our comprehensive service means we can handle Federal, State, and Administrative courts across the country.

## Advanced Docket Research



With over 230 million records, Docket Alarm's cloud-native docket research platform finds what other services can't. Coverage includes Federal, State, plus PTAB, TTAB, ITC and NLRB decisions, all in one place.

Identify arguments that have been successful in the past with full text, pinpoint searching. Link to case law cited within any court document via Fastcase.

## Analytics At Your Fingertips



Learn what happened the last time a particular judge, opposing counsel or company faced cases similar to yours.

Advanced out-of-the-box PTAB and TTAB analytics are always at your fingertips.

## API

Docket Alarm offers a powerful API (application programming interface) to developers that want to integrate case filings into their apps.

## LAW FIRMS

Build custom dashboards for your attorneys and clients with live data direct from the court.

Automate many repetitive legal tasks like conflict checks, document management, and marketing.

## FINANCIAL INSTITUTIONS

Litigation and bankruptcy checks for companies and debtors.

## E-DISCOVERY AND LEGAL VENDORS

Sync your system to PACER to automate legal marketing.