

(12) **United States Patent**
Gorelik et al.

(10) **Patent No.:** **US 7,970,713 B1**
(45) **Date of Patent:** **Jun. 28, 2011**

(54) **METHOD AND APPARATUS FOR
AUTOMATIC PRICING IN ELECTRONIC
COMMERCE**

(75) Inventors: **Vladimir Gorelik**, Palo Alto, CA (US);
Andrew Ian Atherton, San Francisco,
CA (US); **Nina Barrameda Zumel**, San
Francisco, CA (US)

(73) Assignee: **OIP Technologies, Inc.**, San Francisco,
CA (US)

(*) Notice: Subject to any disclaimer, the term of this
patent is extended or adjusted under 35
U.S.C. 154(b) by 1340 days.

(21) Appl. No.: **09/568,001**

(22) Filed: **May 10, 2000**

(51) **Int. Cl.**
G06F 17/00 (2006.01)

(52) **U.S. Cl.** **705/400; 705/1.1; 705/7.29; 705/7.35;**
705/26.1; 705/26.61

(58) **Field of Classification Search** **705/400,**
705/1.1, 7.29, 7.35, 26.1, 26.61
See application file for complete search history.

(56) **References Cited**

U.S. PATENT DOCUMENTS

3,581,072	A *	5/1971	Nymeyer	705/37
5,331,544	A *	7/1994	Lu et al.	705/10
5,778,357	A *	7/1998	Kolton et al.	707/2
5,873,069	A *	2/1999	Reuhl et al.	705/20
6,196,458	B1	3/2001	Walker et al.	
6,230,150	B1 *	5/2001	Walker et al.	705/400
6,233,564	B1	5/2001	Schulze, Jr.	
6,424,949	B1	7/2002	Deaton et al.	
6,477,180	B1	11/2002	Aggarwal et al.	
6,539,392	B1 *	3/2003	Rebane	707/101

FOREIGN PATENT DOCUMENTS

WO WO 02/010961 * 7/2001

OTHER PUBLICATIONS

“Navigating the Intersection of forecasting, market research and pricing” by Cook, Aug. 1995, *Pharmaceutical Executive*, v15, n8, p. 54-58.*

“Pricing research for decision making” by Mohn, winter 1995, *Marketing Research, a Magazine of Management & Applications*, v&n1 p. 10-19.*

“Pricing decision in small firms: Theory and practice” by Cunningham, 1993, *Management Decision*, v31n& p. 46-55.*

A guide to conducting marketing research on the Internet by Emery, Jan. 1996 in *Potentials in Marketing* v23, n1, p22, entire document.*

* cited by examiner

Primary Examiner — Janice A. Mooneyham

Assistant Examiner — Michael J Fisher

(74) *Attorney, Agent, or Firm* — Hickman Palermo Truong & Becker LLP

(57) **ABSTRACT**

An automatic pricing method and apparatus for use in electronic commerce environments is described. Automatic pricing uses live price testing to estimate and measure demand for specific products—taking into account where appropriate, a vendor selected segmentation scheme. The results of live price testing are compared using a vendor selected goal function, e.g. profit maximization, to select a new price. A goal function that balances short term gains versus long term gains based on customer lifetime value is described. The live price testing approach used is designed to minimize losses due to price testing through statistical methods. Additionally, methods for distributing price testing across time so as to avoid problems caused by too many ongoing tests as well as side effects from testing are described. The selected price is a win for both purchasers and vendors as the automatic price will approximate the efficiency of a reverse auction without the inconvenience of the auction format while being goal maximizing for the vendor. For example, a vendor that normally sets prices of items for sale to customers can use embodiments of the invention to great effect.

62 Claims, 7 Drawing Sheets

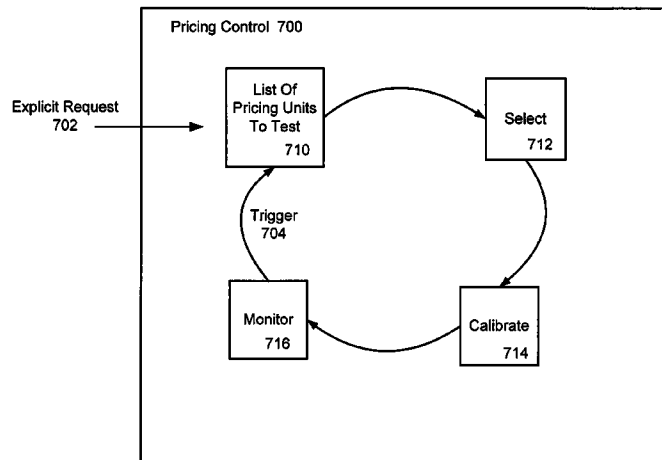

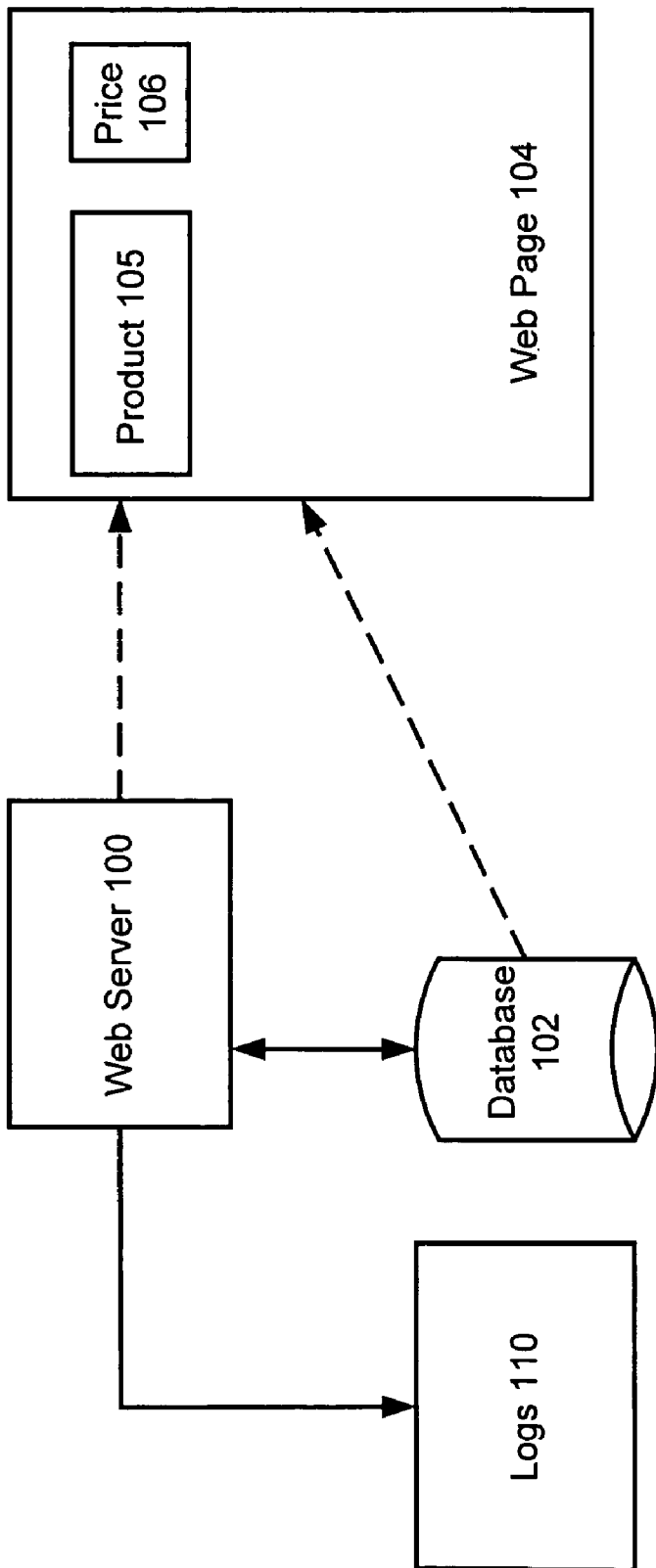

FIG. 1
(Prior Art)

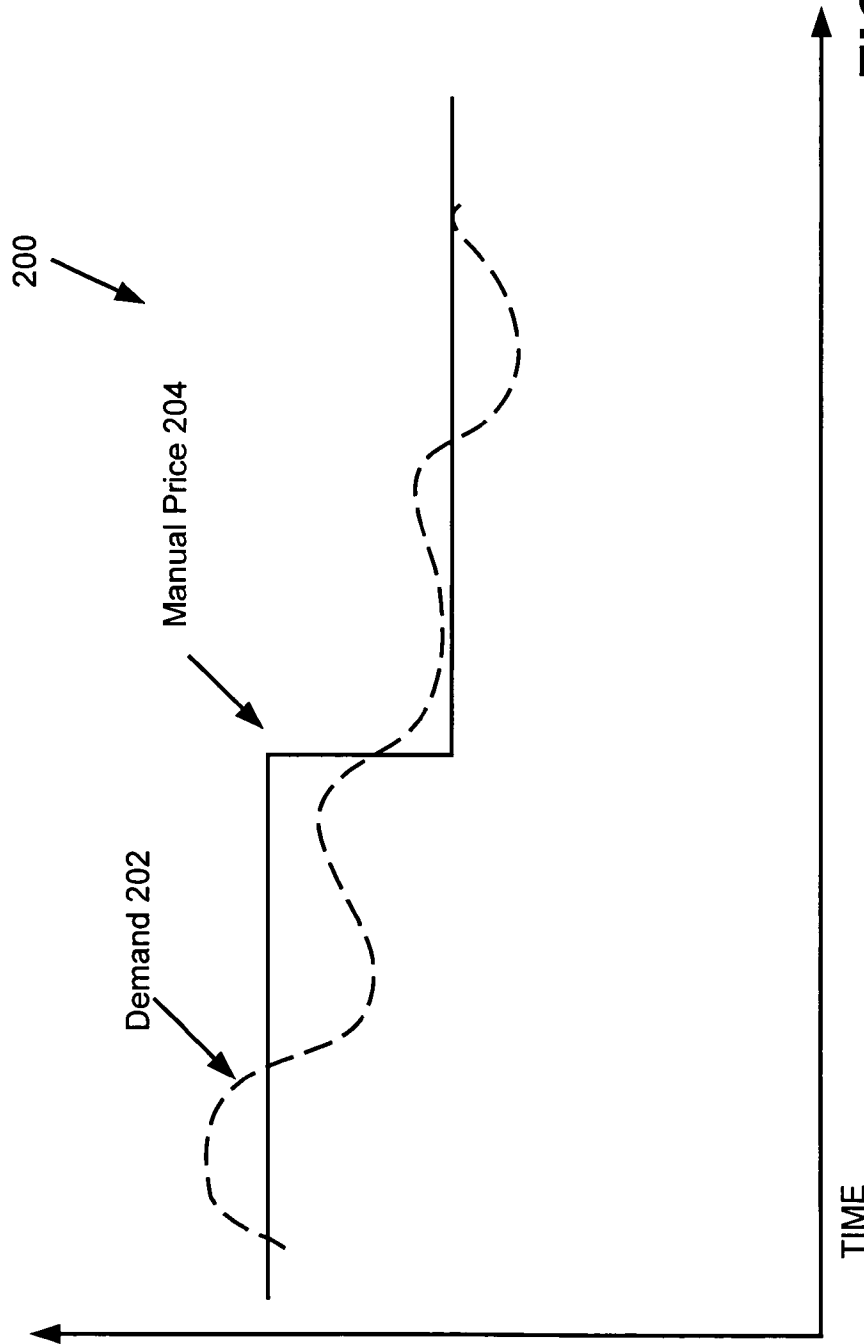

FIG. 2
(Prior Art)

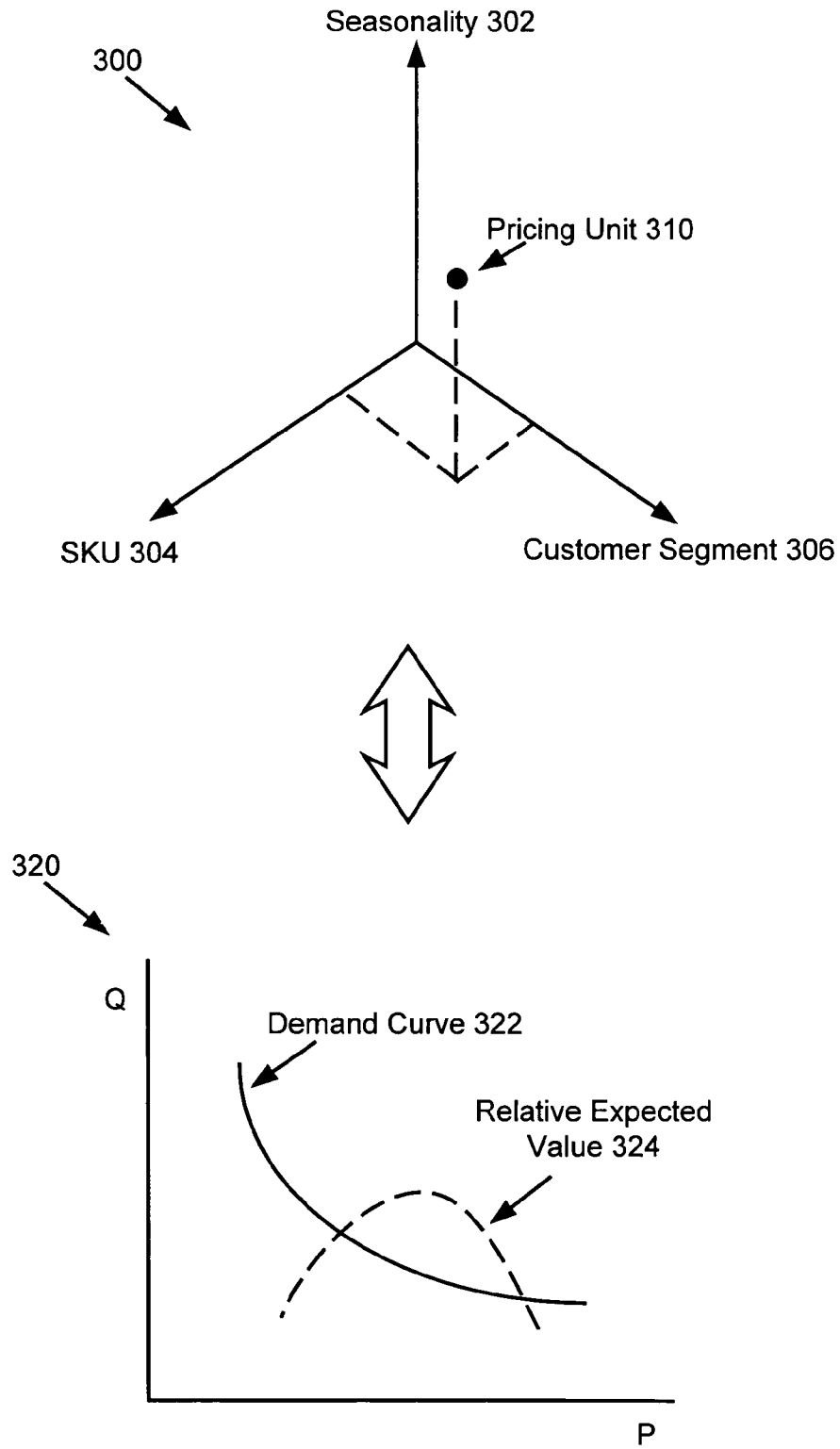

FIG. 3

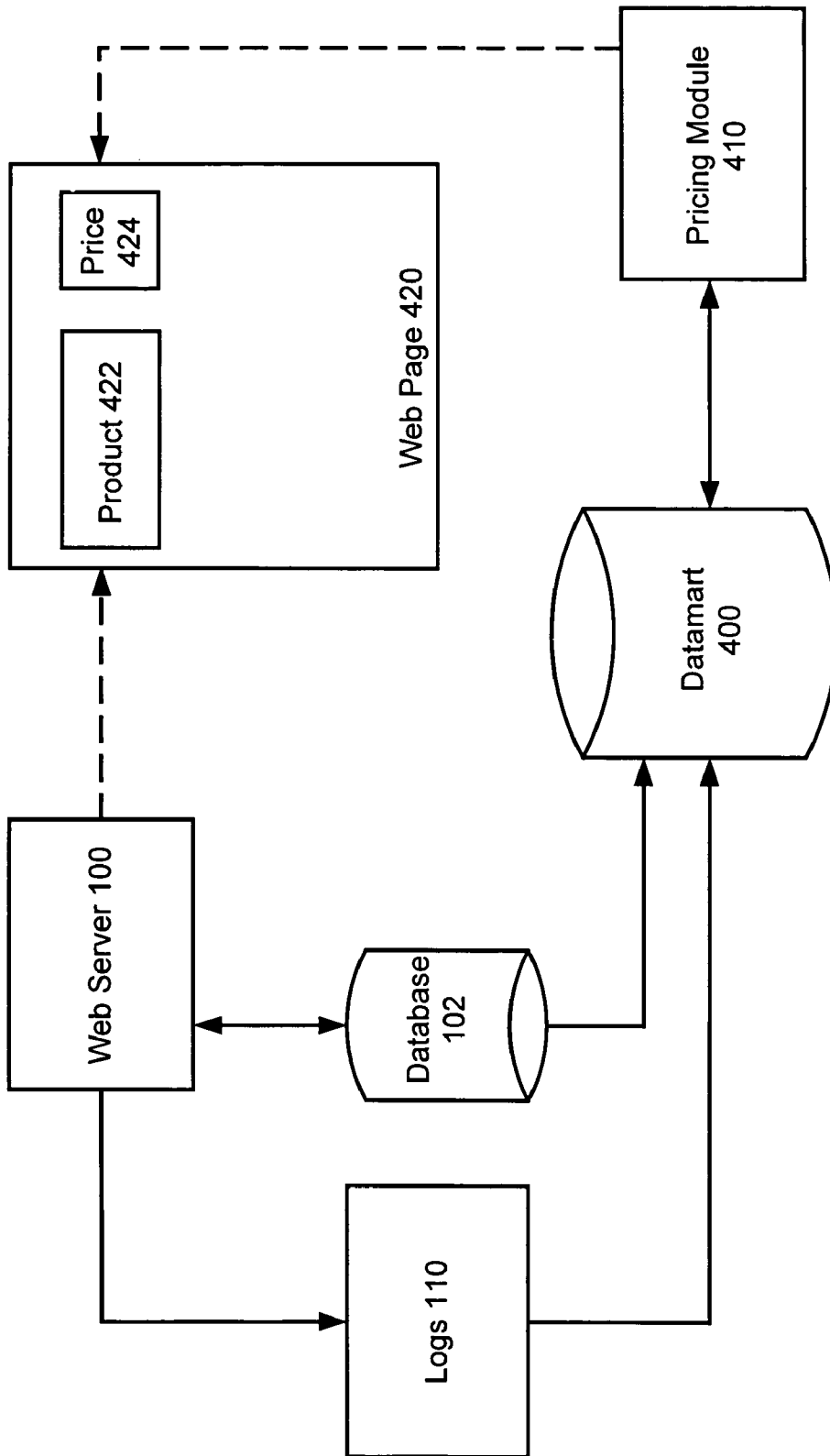

FIG. 4

Explore Litigation Insights

Docket Alarm provides insights to develop a more informed litigation strategy and the peace of mind of knowing you're on top of things.

Real-Time Litigation Alerts



Keep your litigation team up-to-date with **real-time alerts** and advanced team management tools built for the enterprise, all while greatly reducing PACER spend.

Our comprehensive service means we can handle Federal, State, and Administrative courts across the country.

Advanced Docket Research



With over 230 million records, Docket Alarm's cloud-native docket research platform finds what other services can't. Coverage includes Federal, State, plus PTAB, TTAB, ITC and NLRB decisions, all in one place.

Identify arguments that have been successful in the past with full text, pinpoint searching. Link to case law cited within any court document via Fastcase.

Analytics At Your Fingertips



Learn what happened the last time a particular judge, opposing counsel or company faced cases similar to yours.

Advanced out-of-the-box PTAB and TTAB analytics are always at your fingertips.

API

Docket Alarm offers a powerful API (application programming interface) to developers that want to integrate case filings into their apps.

LAW FIRMS

Build custom dashboards for your attorneys and clients with live data direct from the court.

Automate many repetitive legal tasks like conflict checks, document management, and marketing.

FINANCIAL INSTITUTIONS

Litigation and bankruptcy checks for companies and debtors.

E-DISCOVERY AND LEGAL VENDORS

Sync your system to PACER to automate legal marketing.