

48. (new) An information management and synchronous communications system comprising:

- a. a central database containing applications and data,
- b. a first computing device associated with the central database,
- c. a second computing device associated with a second storage medium containing applications and data,
- d. an applications program interface, and
- e. a communications control module;

wherein applications or data are synchronized between the central database and the second storage medium and wherein the applications program interface and communications control module establish a seamless link between the data in the central database and the data on the second storage medium.

49. (new) The information management and synchronous communications system of claim 48 wherein the communications control module and the applications program interface enable the automatic generation of and updating of operator menus or screens on the second computing device based on data from the central database.

50. (new) The information management and synchronous communications system of claim 1 wherein the second menu is generated by manually selecting items from the first menu, adding items to the second menu or assigning parameters to items in the second menu.

51. (new) The information management and synchronous communications system of claim 1 wherein the data is synchronized by digital transmission between the data storage device connected to the central processing unit and at least one other computing device.

52. (new) The information management and synchronous communications system of claim 12 wherein the modified menu is generated by manually selecting items from the master menu.

53. (new) The information management and synchronous communications system of claim 12 wherein the data is synchronized by digital transmission between the data storage device and at least one other computing device.

54. (new) The computer system of claim 31 wherein the data is synchronized by digital transmission between the storage device and at least one other data storage medium.

55. (new) The information management and synchronous communications system of claim 40 wherein the applications and data are synchronized by digital data transmission between the central database, at least one wireless handheld computing device, at least one Web server and at least one Web page.

56. (new) The information management and synchronous communications system of claim 44 wherein the applications or data are synchronized by digital data transmission between the central database and at least one wireless handheld computing device.

57. (new) The information management and synchronous communications system of claim 47 wherein the applications or data are synchronized by digital data transmission between the central database, at least one wireless computing device and at least one wireless paging or beeper device.

a4

16
12

REMARKS

By the present amendment, claims 1, 12 and 31 are amended. Claims 20-30 and 40-43 were allowed. New claims 44-57 have been added. Claims 1-57 are now pending. No new matter has been added.

Claims 1-19 and 31-39 were rejected under 35 U.S.C. 102(e) as anticipated by Cupps et al. U.S. Patent No. 5,991,739. Claims 1, 12 and 31 have been amended to further recite that the data comprising the second or modified menu is synchronized between the data storage device connected to the central processing unit and at least one other computing device. Cupps

describes the dynamic creation of menu web pages that are customized to a customer's request. (See, e.g., col. 9, lines 3-7). However, Cupps does not describe the synchronization of generated menus between different databases or computing devices. As a matter of fact, Cupps describes data transmission via phone or fax (e.g., col.10, lines 26-42) precisely because Cupps did not appreciate what Applicants describe and claim, i.e., real-time synchronization of data on different computers or databases. Claims 1, 12 and 31 as amended are thus believed to be patentably distinguishable over Cupps.

Claims 2-11, 13-19 and 32-39 further contribute to the claiming of the invention because they are directed to further aspects of the claimed device. Claims 2-11, 13-19 and 32-39 depend from claims 1, 12 or 31. With the amendments to claims 1, 12 and 31, it is respectfully submitted that claims 2-11, 13-19 and 32-39 are now allowable.

New claims 44-57 recite further aspects of the invention which Applicants are entitled to claim. Claims 44-49 find support in the specification, e.g., at page 21, lines 8-10 and 14-15; page 20, line 8 – page 21, line 3 and page 25, line 10 – page 26, line 8. Support for new claims 50 and 52 is found, e.g., at p. 12, line 3 - page 15, line 25. Support for new claims 51 and 53-57 is found, e.g., at page 1, line 17 and p. 2, lines 2-3. No new matter has been added. Applicants respectfully submit that new claims 44-57 are distinguishable and patentable over the prior art of record.

To avoid any negative inference, Applicants state for the record that they respectfully disagree with the Examiner's statements with regard to claims 1-19 and 31-39 that Cupps discloses a synchronous communications system. Applicants further disagree with the Examiner's statements with respect to claims 8 and 16 that Cupps discloses creating the second menu in conformity with extensible markup language. In any event, claims 1-19 and 31-39 as amended are asserted to be patentable over the prior art of record as discussed above.

It is therefore respectfully submitted that the invention as now claimed in rejected claims 1-19 and 31-39 and new claims 44-57 is patentable over the cited references and those claims are in condition for allowance. Accordingly, reconsideration and withdrawal of the rejection of claims 1-19 and 31-39 and allowance of the pending claims, being claims 1-57, is respectfully requested.

Respectfully submitted,
Morgan & Finnegan, L.L.P.

Date: February 26, 2001

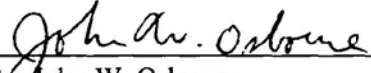
By: John W. Osborne
Registration No. 36,231

Mailing Address:
MORGAN & FINNEGAN, L.L.P.
345 Park Avenue
New York, NY 10154-0053
TELEPHONE: 212-758-4800
TELECOPIER: 212-751-6849



#6

PATENT

Docket No. 3125-4002US1

IN THE UNITED STATES PATENT AND TRADEMARK OFFICE

Applicant(s) : McNally et al.
 Serial No. : 09/400,413 Group Art Unit: 2173
 Filed : September 21, 1999 Examiner: Cao Nguyen
 For : INFORMATION MANAGEMENT AND SYNCHRONOUS
 COMMUNICATIONS SYSTEM WITH MENU GENERATION

AMENDMENT FEE TRANSMITTAL

ASSISTANT COMMISSIONER FOR PATENTS
 Washington, D.C. 20231

Sir:

Transmitted herewith is an Amendment for the above-identified application.

- No additional fee is required.
- The additional fee has been calculated as shown below:

CLAIMS AS AMENDED

	Claims Remaining After Amendment	Highest No. Covered by Previous Payments	Present Extra	Rate	Additional Fee
Total Claims	57	- 43	= 14	x \$18.00	\$252.00
Independent Claims	8	- 5	= 3	x \$80.00	\$240.00
Multiple Dependent Claim(s)	(If claims added by amendment include Multiple Dependent Claim(s) and there was not Multiple Dependent Claims(s) in application before amendment add \$270.00 to additional fee.)				\$0.00
Total:					\$492.00

- Statement of "Small Entity" Status Under 37 CFR § 1.27 filed September 21, 1999
 Reduced Fees Under 37 CFR § 1.9(f) (50% of total) paid herewith. \$ 246.00.

* Includes all independent and single dependent claims and all claims referred to in multiple dependent claims. See 37 C.F.R. § 1.75(c).

602176_1

RECEIVED
 MAR 08 2001
 Technology Center 2100

- Charge fee to Deposit Account No. 13-4500. Order No. _____
A DUPLICATE COPY OF THIS SHEET IS ATTACHED.
- The Assistant Commissioner is hereby authorized to charge any additional fees which may be required for this amendment, including all fees pursuant to 37 C.F.R. § 1.17 for its timely consideration, or credit any overpayment to Deposit Account No. 13-4500. Order No. 3125-4002US1 _____. A DUPLICATE COPY OF THIS SHEET IS ATTACHED.
- ___ Page(s) of substitute Sequence Listing
- ___ Computer disk(s) containing substitute Sequence Listing
- Statement under 37 C.F.R. § 1.825(b) that the computer and paper copies of the substitute Sequence Listing are the same.
- A check in the amount of \$ 246.00 to cover the filing fee is attached.

Respectfully submitted,

MORGAN & FINNEGAN, L.L.P.

Dated: February 26, 2001

By: _____

John W. Osborne
John W. Osborne
Reg. No. 36,231

CORRESPONDENCE ADDRESS:

MORGAN & FINNEGAN, L.L.P.
345 Park Avenue
New York, New York 10154
(212) 758-4800
(212) 751-6849 Facsimile

FORM: AMD-TRAN.NY
Rev. 10/01/00



GAU
2173
PATENT #

Docket No. 3125-4002US1

IN THE UNITED STATES PATENT AND TRADEMARK OFFICE

Applicant(s) : McNally et al.
Serial No. : 09/400,413 Group Art Unit: 2173
Filed : September 21, 1999 Examiner: Cao Nguyen
For : INFORMATION MANAGEMENT AND SYNCHRONOUS
COMMUNICATIONS SYSTEM WITH MENU GENERATION

CERTIFICATE OF MAILING (37 C.F.R. 1.8a)

ASSISTANT COMMISSIONER FOR PATENTS
Washington, D.C. 20231

Sir:

I hereby certify that the attached Amendment Fee Transmittal; Amendment; Check for \$188.00;
Check for \$58.00; and Postcard.

along with any paper(s) referred to as being attached or enclosed and this Certificate of Mailing are being deposited with the United States Postal Service on date shown below with sufficient postage as first-class mail in an envelope addressed to the: Assistant Commissioner for Patents, Washington, D.C. 20231.

Respectfully submitted,

MORGAN & FINNEGAN, L.L.P.

Dated: February 26, 2001

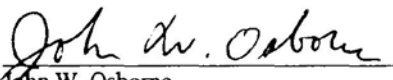
John W. Osborne
Reg. No. 36,231

CORRESPONDENCE ADDRESS:
MORGAN & FINNEGAN LLP
345 Park Avenue
New York, New York 10154
(212) 758-4800
(212) 751-6849 Facsimile

FORM: CERT..NY
Rev. 05/27/98

RECEIVED
MAR 0 8 2001
Technology Center 2100

602254_1



7

PATENT

Attorney Docket No. 3125-4002US1

IN THE UNITED STATES PATENT AND TRADEMARK OFFICE

Applicant : McNally et al. Group Art Unit: 2173
 Serial No. : 09/400,413 Examiner: Cao Nguyen
 Filed : September 21, 1999
 For : INFORMATION MANAGEMENT AND SYNCHRONOUS
 COMMUNICATIONS SYSTEM WITH MENU GENERATION

SUBMISSION OF FORMAL DRAWINGS

Assistant Commissioner For Patents
 Washington, D.C. 20231
Attn: OFFICIAL DRAFTSPERSON

Sir :

Enclosed for filing in the above-identified application are six (6) sheets of formal drawings containing Figures 1-7, corrected as required by the Official Draftsperson in the Notice of Draftsperson's Patent Drawing Review dated February 7, 2000.

Please substitute the enclosed drawings for those presently on file.

Respectfully submitted,

Dated: February 26, 2001

By: *John W. Osborne*
 John W. Osborne
 Registration No. 36,231

Mailing Address:

MORGAN & FINNEGAN, L.L.P.
 345 Park Avenue
 New York, New York 10154-0053
 (212) 758-4800
 (212) 751-6849 (FAX)

RECEIVED
 MAR -8 2001
 TOLSON MAILROOM

602276_1

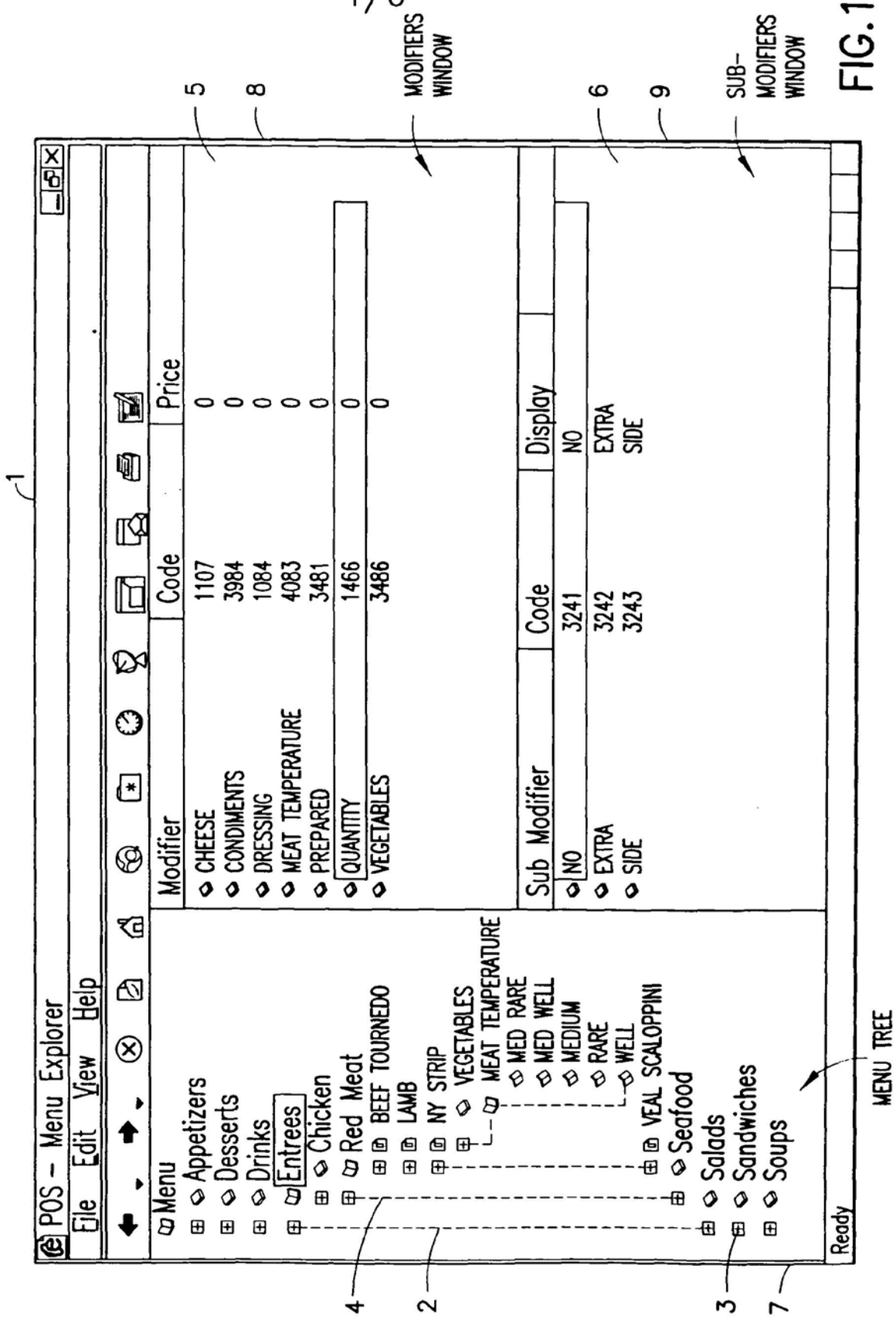

FIG. 1

Modifier ✕

Long Name:

Short Name:

Code:

Price:

10

FIG.2

Menu Category ✕

Long Name:

Short Name:

FIG.3

INFORMATION MANAGEMENT AND
SYNCHRONOUS COMMUNICATIONS SYSTEM
WITH MENU GENERATION

Inventors: Keith McNally

Docket No.: 3125-4002US1

Morgan & Finnegan, LLP

Angus R. Gill, Reg. No. 51,133

Formal Drawing Sheets 2 of 6 (Figs. 1-7)

Menu Item

Long Name: Chicken Alaska Code: 5612

Short Name: ChxAls Price: 12.95 Prep. Time: 12

Recipe

Flame broiled brandy marinated Tender Chicken Breast topped with a creamy cilantro sauce. Served with steamed broccoli, carrots and zucchini.

Spices include lemon pepper, paprika, ginger.

OK Cancel Browse

12

FIG.4

INFORMATION MANAGEMENT AND
SYNCHRONOUS COMMUNICATIONS
SYSTEM WITH MENU GENERATION

Inventors: Keith McNally

Docket No.: 3125-4002US1

Morgan & Finnegan, LLP

Angus R. Gill, Reg. No. 51,133

Formal Drawing Sheets 3 of 6 (Figs. 1-7)

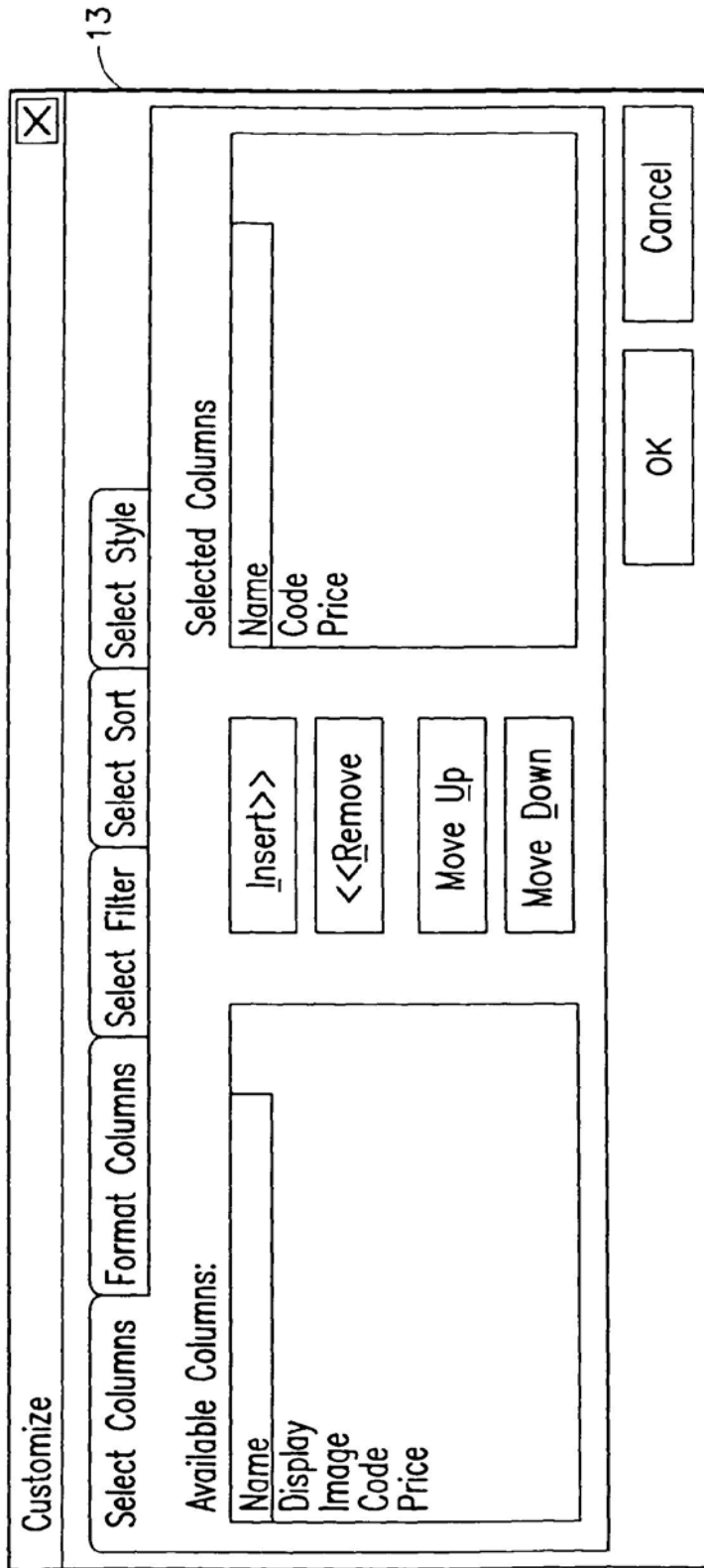

FIG.5

INFORMATION MANAGEMENT AND
SYNCHRONOUS COMMUNICATIONS SYSTEM
WITH MENU GENERATION

Inventors: Keith McNally

Docket No.: 3125-4002US1

Morgan & Finnegan, LLP

Angus R. Gill, Reg. No. 51,133

Formal Drawing Sheets 4 of 6 (Figs. 1-7)

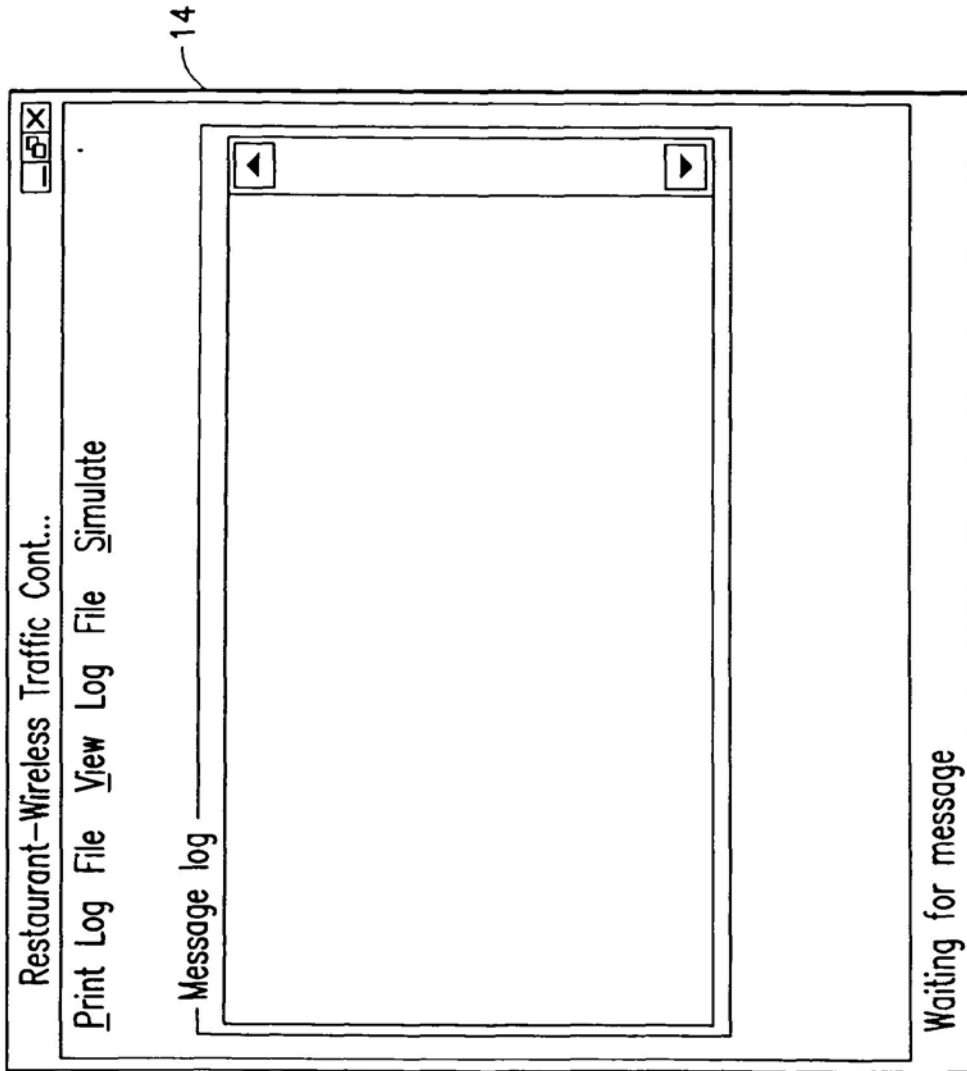

FIG.6

INFORMATION MANAGEMENT AND
SYNCHRONOUS COMMUNICATIONS
SYSTEM WITH MENU GENERATION

Inventors: Keith McNally

Docket No.: 3125-4002US1

Morgan & Finnegan, LLP

Angus R. Gill, Reg. No. 51,133

Formal Drawing Sheets 5 of 6 (Figs. 1-7)

POScE--System

15

16

Close

Login CHECKS ORDER VIEW PAY

Choose Item: Tbl67 5st 2

App	Dessert	Drinks	Entrees
Salads	Sdwch	Soups	

Direction:

MAIN PREV PAGE MODS

Select Guest to Order for:

1 2

Last Selection

REMOVE LAST

OK Cancel Browse

FIG.7

INFORMATION MANAGEMENT AND
SYNCHRONOUS COMMUNICATIONS SYSTEM
WITH MENU GENERATION
Inventors: Keith McNally
Docket No.: 3125-4002US1
Morgan & Finnegan, LLP
Angus R. Gill, Reg. No. 51,133
Formal Drawing Sheets 6 of 6 (Figs. 1-7)

#77/ Formal IP/2173
4/17/01



PATENT

Docket No. 3125-4002US1

IN THE UNITED STATES PATENT AND TRADEMARK OFFICE

Applicant(s) : McNally et al.
Serial No. : 09/400,413 Group Art Unit: 2173
Filed : September 21, 1999 Examiner: Cao Nguyen
For : INFORMATION MANAGEMENT AND SYNCHRONOUS COMMUNICATIONS SYSTEM WITH MENU GENERATION

CERTIFICATE OF MAILING (37 C.F.R. 1.8a)

ASSISTANT COMMISSIONER FOR PATENTS
Washington, D.C. 20231

Sir:

I hereby certify that the attached Submission of Formal Drawings, Six (6) Sheets of Formal Drawings (Figs. 1-7); and Postcard.

along with any paper(s) referred to as being attached or enclosed and this Certificate of Mailing are being deposited with the United States Postal Service on date shown below with sufficient postage as first-class mail in an envelope addressed to the: Assistant Commissioner for Patents, Washington, D.C. 20231.

Respectfully submitted,
MORGAN & FINNEGAN, L.L.P.

Dated: February 26, 2001

John W. Osborne
John W. Osborne
Reg. No. 36,231

CORRESPONDENCE ADDRESS:
MORGAN & FINNEGAN LLP
345 Park Avenue
New York, New York 10154
(212) 758-4800
(212) 751-6849 Facsimile

FORM: CERT..NY
Rev. 05/27/98

RECEIVED
MAR - 8 2001
2600 MAIL ROOM

602279_1



#8/1/01 GAU 2173
T. 2173
3/17/01
Docket No. 3125-4002US1

IN THE UNITED STATES PATENT AND TRADEMARK OFFICE

Applicant(s) : McNally et al.
Serial No. : 09/400,413 Group Art Unit: 2173
Filed : September 21, 1999 Examiner: Cao Nguyen
For : INFORMATION MANAGEMENT AND SYNCHRONOUS
COMMUNICATIONS SYSTEM WITH MENU GENERATION

RECEIVED
MAR 20 2001
Group 2100

Assistant Commissioner for Patents
Washington, D.C. 20231

LETTER CONCERNING NOTICE OF REFERENCES CITED IN OFFICE ACTION

Sir:

The previous communication dated November 29, 2000 (paper no. 5) received from the U.S. Patent and Trademark Office (PTO) indicates an incorrect patent number for item (c) which is listed as document number 5,912,734. The correct number should read "5,912,743".

We enclosed a copy of the Notice of References Cited for your reference. To ensure that the application issues with the correct information, Applicant respectfully requests correction of said item.

Respectfully submitted,
MORGAN & FINNEGAN

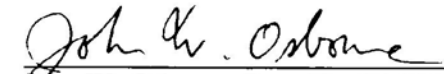
John W. Osborne, Reg. No. 36,231

Date: March 8, 2001

Mailing Address
MORGAN & FINNEGAN
345 Park Avenue
New York, New York 10154
(212) 758-4800



**UNITED STATES DEPARTMENT OF COMMERCE
Patent and Trademark Office**

Address: COMMISSIONER OF PATENTS AND TRADEMARKS
Washington, D.C. 20231

APPLICATION NO.	FILING DATE	FIRST NAMED INVENTOR	ATTORNEY DOCKET NO.
-----------------	-------------	----------------------	---------------------

09/400,413	09/21/99	MCNALLY	3125-400
------------	----------	---------	----------

EXAMINER

TN02/1129

JOHN W. OSBORNE
MORGAN & FINNEGAN, LLP
240 PARK AVENUE
NEW YORK, NY 10154

ART UNIT	PAPER NUMBER
----------	--------------

DATE MAILED:

Please find below and/or attached an Office communication concerning this application or proceeding.

Commissioner of Patents and Trademarks

RECEIVED

MAR 20 2001

Group 2100

MORGAN & FINNEGAN LLP

DEC -4 P 12:22

RECEIVED
BOOKLET DEP. 17.

CASE 3125-4002 ATTY JWD
 DUE DATE February 28, 2001
 STATUTORY DATE May 28, 2001
 BY [Signature]



Notice of References Cited

Application No. 09/400,413	Applicant(s) McNally et al.
Examiner Cao "Kevin" Nguyen	Group Art Unit 2173

U.S. PATENT DOCUMENTS

	DOCUMENT NO.	DATE	NAME	CLASS	SUBCLASS
A	✓ 5,724,069	3/98	CHEN	345	156
B	✓ 5,991,739	11/99	CUPPS et al.	705	26
C	✓ 5,912,734 743	6/99	Kinebuchi et al.	345	348
D	✓ 5,802,526	1/98	Fawcett et al.	707	104
E					
F					
G					
H					
I					
J					
K					
L					

RECEIVED
MAR 20 2001
Group 2100

FOREIGN PATENT DOCUMENTS

	DOCUMENT NO.	DATE	COUNTRY	NAME	CLASS	SUBCLASS
M						
N						
O						
P						
Q						
R						

NON-PATENT DOCUMENTS

	DOCUMENT (Including Author, Title, Source, and Pertinent Pages)	DATE
U		
V		
W		
X		

6



**UNITED STATES DEPARTMENT OF COMMERCE
United States Patent and Trademark Office**

Address: COMMISSIONER OF PATENTS AND TRADEMARKS
Washington, D.C. 20231

[Handwritten signature]

APPLICATION NO.	FILING DATE	FIRST NAMED INVENTOR	ATTORNEY DOCKET NO.
-----------------	-------------	----------------------	---------------------

09/400,413 09/21/99 MCNALLY

K 3125-400
EXAMINER

TM02/0522

JOHN W. OSBORNE
MORGAN & FINNEGAN, LLP
345 PARK AVENUE
NEW YORK NY 10154

ARGUMENT, PAPER NUMBER *9*

DATE MAILED:

05/22/01

Please find below and/or attached an Office communication concerning this application or proceeding.

Commissioner of Patents and Trademarks

Office Action Summary

Application No. 09/400,413	Applicant(s) McNally et al.
Examiner Cao "Kevin" Nguyen	Art Unit 2173

-- The MAILING DATE of this communication appears on the cover sheet with the correspondence address --

Period for Reply

A SHORTENED STATUTORY PERIOD FOR REPLY IS SET TO EXPIRE 3 MONTH(S) FROM THE MAILING DATE OF THIS COMMUNICATION.

- Extensions of time may be available under the provisions of 37 CFR 1.136 (a). In no event, however, may a reply be timely filed after SIX (6) MONTHS from the mailing date of this communication.
- If the period for reply specified above is less than thirty (30) days, a reply within the statutory minimum of thirty (30) days will be considered timely.
- If NO period for reply is specified above, the maximum statutory period will apply and will expire SIX (6) MONTHS from the mailing date of this communication.
- Failure to reply within the set or extended period for reply will, by statute, cause the application to become ABANDONED (35 U.S.C. § 133).
- Any reply received by the Office later than three months after the mailing date of this communication, even if timely filed, may reduce any earned patent term adjustment. See 37 CFR 1.704(b).

Status

- 1) Responsive to communication(s) filed on Mar 1, 2001
- 2a) This action is FINAL. 2b) This action is non-final.
- 3) Since this application is in condition for allowance except for formal matters, prosecution as to the merits is closed in accordance with the practice under *Ex parte Quayle*, 35 C.D. 11, 453 O.G. 213.

Disposition of Claims

- 4) Claim(s) 1-19, 31-39, 44-54, 56, and 57 is/are pending in the application.
- 4a) Of the above, claim(s) _____ is/are withdrawn from consideration.
- 5) Claim(s) 20-30 and 40-43 and 55 is/are allowed.
- 6) Claim(s) 1-19, 31-39, 44-54, 56, and 57 is/are rejected.
- 7) Claim(s) _____ is/are objected to.
- 8) Claims _____ are subject to restriction and/or election requirements.

Application Papers

- 9) The specification is objected to by the Examiner.
- 10) The drawing(s) filed on _____ is/are objected to by the Examiner.
- 11) The proposed drawing correction filed on _____ is: a) approved b) disapproved.
- 12) The oath or declaration is objected to by the Examiner.

Priority under 35 U.S.C. § 119

- 13) Acknowledgement is made of a claim for foreign priority under 35 U.S.C. § 119(a)-(d).
- a) All b) Some* c) None of:
- Certified copies of the priority documents have been received.
 - Certified copies of the priority documents have been received in Application No. _____.
 - Copies of the certified copies of the priority documents have been received in this National Stage application from the International Bureau (PCT Rule 17.2(a)).
- *See the attached detailed Office action for a list of the certified copies not received.
- 14) Acknowledgement is made of a claim for domestic priority under 35 U.S.C. § 119(e).

Attachment(s)

- 15) Notice of References Cited (PTO-892) 18) Interview Summary (PTO-413) Paper No(s) _____
- 16) Notice of Draftsperson's Patent Drawing Review (PTO-948) 19) Notice of Informal Patent Application (PTO-152)
- 17) Information Disclosure Statement(s) (PTO-1449) Paper No(s) _____ 20) Other

Art Unit: 2173

DETAILED ACTION

Claim Rejections - 35 USC § 102

1. The following is a quotation of the appropriate paragraphs of 35 U.S.C. 102 that form the basis for the rejections under this section made in this Office action:

A person shall be entitled to a patent unless --

(e) the invention was described in a patent granted on an application for patent by another filed in the United States before the invention thereof by the applicant for patent, or on an international application by another who has fulfilled the requirements of paragraphs (1), (2), and (4) of section 371© of this title before the invention thereof by the applicant for patent.

2. Claims 1-19, 31-39 and ~~50-54~~ are rejected under 35 U.S.C. 102(e) as being anticipated by Cupps et al. (5,991,739). RB

Regarding claim 1, Cupps discloses an information management and synchronous communications system for generating menus comprising: a central processing unit, a data storage device connected to said central processing unit, an operating system including a graphical user interface (see figure 2), a first menu stored on said data storage device, application software for generating a second menu from said first menu, wherein the application software facilitates the generation of the second menu by allowing selection of items from the first menu, addition of items to the second menu and assignment of parameters to items in the second menu using the graphical user interface of said operating system (see col. 9, lines 42-67).

Regarding claim 2, Cupps discloses an information management and synchronous communications system, wherein the second menu is a restaurant menu (see col. 5, lines 27-67).

Art Unit: 2173

Regarding claim 3, Cupps discloses an information management and synchronous communications system, wherein the second menu is capable of being displayed on the display screen of a wireless computing device (see col. 4, lines 1-55).

Regarding claims 4 and 5, Cupps discloses an information management and synchronous communications system, wherein selections from the second menu are capable of being transmitted to a receiving computer by wireless link.(see figures 1-2).

Regarding claims 6 and 7, Cupps discloses an information management and synchronous communications system in, wherein the computer network is the internet; and selections from the second menu are capable of being transmitted to a receiving computer via the internet (see col. 9, lines 16-65 and figure 8-10).

Regarding claims 8-11, Cupps discloses an information management and synchronous communications system, wherein the second menu is created in conformity with hypertext markup language or extensible markup language (see col. 10, lines 8-56 and figures 7-10).

As claims 12-19, 31-39 and 50-54 are analyzed as previously discussed with respect to claims 1-11 above.

Art Unit: 2173

Claim Rejections - 35 USC § 103

3. The following is a quotation of 35 U.S.C. 103(a) which forms the basis for all obviousness rejections set forth in this Office action:

(a) A patent may not be obtained though the invention is not identically disclosed or described as set forth in section 102 of this title, if the differences between the subject matter sought to be patented and the prior art are such that the subject matter as a whole would have been obvious at the time the invention was made to a person having ordinary skill in the art to which said subject matter pertains. Patentability shall not be negated by the manner in which the invention was made.

This application currently names joint inventors. In considering patentability of the claims under 35 U.S.C. 103(a), the examiner presumes that the subject matter of the various claims was commonly owned at the time any inventions covered therein were made absent any evidence to the contrary. Applicant is advised of the obligation under 37 CFR 1.56 to point out the inventor and invention dates of each claim that was not commonly owned at the time a later invention was made in order for the examiner to consider the applicability of 35 U.S.C. 103© and potential 35 U.S.C. 102(f) or (g) prior art under 35 U.S.C. 103(a).

4. Claims 44-49 and 56-57 are rejected under 35 U.S.C. 103(a) as being unpatentable over Cupps in view of Behr et al. (US Patent No. 6,107,944).

Regarding claim 44, Cupps fails to explicitly teach at least one wireless handheld computing device on which hospitality application.

Behr teaches wireless handheld computing device on which hospitality application (see col. 14, lines 1-57). It would have been obvious to one of an ordinary skill in the art at the time the invention was made to provide wireless handheld computing device on which hospitality

Art Unit: 2173

application as taught by Behr to the internet on-line ordering vendor of Cupps; in order to provide the customer with the hospitality over the wireless communication device. It would enhance user friendly and to remotely access into the hospitality ordering database.

Regarding claim 45, Behr discloses wherein the communications control module and the application program interface enable automatic generation of and updating of operator menus or screen of the handheld (see figures 33-35).

Regarding claim 46, Cupps discloses wherein Messaging format are used which are conformity with HTML or XML message format (see col. 9, lines 8-65).

As claims 48-49 and 56-57 are analyzed as previously discussed with respect to claims 44-46 above.

Response to Arguments

5. Applicant's arguments filed on 03/01/01 have been fully considered but they are not persuasive.

On page 7, Applicant argues that Cupps fails to explicitly teach or suggest "the second menu is synchronized between the data storage device connected to CPU ". However, the limitations set forth to reply upon "A customer accesses the online ordering machine through a client computer that is connected to the Internet. The customer enters the appropriate web address or universal resource locator (URL) for the online ordering machine. The online order procedure interacts with the client computer by providing access to a series of web pages that can

Art Unit: 2173

be downloaded to the client computer for the customer's use. Initially, a home web page is provided to the client computer. The customer can register with the online ordering machine which is accomplished by filling out information requested through one or more web pages. The customer is then provided with a web page that prompts the customer for his location as shown in the exemplary web page. This web page can also obtain the current time at the customer's location which is returned to the online order procedure. The current time is used to determine which restaurants meeting the customer's criteria are currently open. In addition, the web page obtains the type of service that the customer seeks, such as but not limited to take-out service or delivery service." See Cupps col. 9, lines 35-65 and figures 2-3F.

On page 7, Applicant argues that the claims invention describe a real-time synchronization of data on different computers or database. However, the limitation as claimed was not clearly defined in the claim invention.

Allowable Subject Matter

6. Claims 20-30, 40-43 and 55 are allowed over the prior art of record.

Applicant has claimed uniquely distinct features in the instant invention which are not found in the prior art either singularly or in combination. They are an information management and synchronous communications system for generating and transmitting menus a sub-modifier menu stored on data storage device and displayable in a window of graphical user interface, and

Art Unit: 2173

application software for generating a second menu from first menu and transmitting second menu to a wireless handheld computing device or Web page. These features are not found or suggested in the prior art.

The present invention is directed to an information management and synchronous communications system for generating and transmitting menus. Each independent claims 20 and 40 are identified the uniquely distinct features "a sub-modifier menu stored on data storage device and displayable in a window of graphical user interface, and application software for generating a second menu from first menu and transmitting second menu to a wireless handheld computing device or Web page". The closest prior art, Cupps (US Patent No. 5,991,739) and Chen (US Patent No. 5,724,069) discloses convention of user interactive interface providing an on-line ordering distribution, either singularly or in combination, fail to anticipate or render the above underlined limitations obvious.

Conclusion

7. The prior art made of record and not relied upon is considered pertinent to applicant's disclosure and provided on the attached Form 892.

Art Unit: 2173

8. **THIS ACTION IS MADE FINAL.** Applicant is reminded of the extension of time policy as set forth in 37 CFR 1.136(a).

A shortened statutory period for reply to this final action is set to expire **THREE MONTHS** from the mailing date of this action. In the event a first reply is filed within **TWO MONTHS** of the mailing date of this final action and the advisory action is not mailed until after the end of the **THREE-MONTH** shortened statutory period, then the shortened statutory period will expire on the date the advisory action is mailed, and any extension fee pursuant to 37 CFR 1.136(a) will be calculated from the mailing date of the advisory action. In no event, however, will the statutory period for reply expire later than **SIX MONTHS** from the mailing date of this final action.

Response

9. Responses to this action should be mailed to: Commissioner of Patents and Trademarks, Washington, D.C. 20231. If applicant desires to fax a response, (703) 308-6306 may be used for formal communications.

Please label "PROPOSED" or "DRAFT" for informal facsimile communications. For after final responses, please label "AFTER FINAL" or "EXPEDITED PROCEDURE" on the document.

Art Unit: 2173

Hand-delivered responses should be brought to Crystal Park II, 2121 Crystal Drive,
Arlington, VA. Sixth Floor (Receptionist).

Inquires

10. Any inquiry concerning this communication or earlier communications from the examiner should be directed to Cao (Kevin) Nguyen whose telephone number is (703) 305-3972. The examiner can normally be reached on Monday-Friday from 8:30 am to 6:00 pm.

If attempts to reach the examiner by telephone are unsuccessful, the examiner's supervisor, John W. Cabeca, can be reached on (703) 308-3116. The fax number for this group is (703) 308-6360.

Any inquiry of a general nature or relating to the status of this application or proceeding should be directed to the Group receptionist whose telephone number is (703) 305-3900.

PATENT EXAMINER
Art Unit 2773

Cao "Kevin" Nguyen
May 16, 2001

RAYMOND J. BAYERL
PRIMARY EXAMINER
ART UNIT 2173

Notice of References Cited

Applicant/Patent McNally et al.		Application/Control No. 09/400,413	
Examiner Cao "Kevin" Nguyen		Art Unit 2173	Page 1 of 1

U.S. PATENT DOCUMENTS

	Document Number <small>Country Code-Number-Kind Code</small>	Date <small>MM-YYYY¹</small>	Name	Classification ²	
A	6,107,944	08/00	BEHR et al.	340	995
B					
C					
D					
E					
F					
G					
H					
I					
J					
K					
L					
M					

FOREIGN PATENT DOCUMENTS

	Document Number <small>Country Code-Number-Kind Code</small>	Date <small>MM-YYYY¹</small>	Country	Name	Classification ²
N					
O					
P					
Q					
R					
S					
T					

NON-PATENT DOCUMENTS

	Include, as applicable: Author, Title, Date, Publisher, Edition or Volume, Pertinent Pages
U	
V	
W	
X	

¹ A copy of this reference is not being furnished with this Office action. See MPEP § 707.05(a).

¹ Dates in MM-YYYY format are publication dates.

² Classifications may be U.S. or foreign.



US006107944A

United States Patent [19]
Behr et al.

[11] **Patent Number:** **6,107,944**
[45] **Date of Patent:** ***Aug. 22, 2000**

[54] **ELECTRONIC NAVIGATION SYSTEM AND METHOD**

[75] **Inventors:** **David A. Behr, Roselle; Ramesh Ramakrishnan, Mount Prospect, both of Ill.**

[73] **Assignee:** **Navigation Technologies Corporation, Rosemont, Ill.**

[*] **Notice:** This patent issued on a continued prosecution application filed under 37 CFR 1.53(d), and is subject to the twenty year patent term provisions of 35 U.S.C. 154(a)(2).

[21] **Appl. No.:** **09/151,255**
[22] **Filed:** **Sep. 10, 1998**

Related U.S. Application Data

[63] Continuation of application No. 08/494,198, Jun. 23, 1995, Pat. No. 5,808,566, which is a continuation-in-part of application No. 08/265,094, Jun. 24, 1994, Pat. No. 5,543,789.

[51] **Int. Cl.**⁷ **G08G 1/123**
[52] **U.S. Cl.** **340/995; 340/988; 701/208; 701/209; 701/211**
[58] **Field of Search** **340/995, 990, 340/991, 988, 905; 701/209, 211, 208, 210**

[56] **References Cited**

U.S. PATENT DOCUMENTS

4,301,506	11/1981	Turco .	
4,311,876	1/1982	Endo et al.	340/905
4,428,057	1/1984	Setliff et al. .	
4,466,125	8/1984	Kanayama 340/990	
4,481,584	11/1984	Holland .	
4,546,439	10/1985	Esparza .	
4,570,227	2/1986	Tachi et al. .	
4,642,775	2/1987	Cline et al. .	
4,733,356	3/1988	Haussermann et al. .	

(List continued on next page.)

FOREIGN PATENT DOCUMENTS

0 379 198 A3	7/1990	European Pat. Off. .
0 585 950 A2	9/1993	European Pat. Off. .
41 41 597 A1	12/1991	Germany .
3150699	6/1991	Japan .
6266997	9/1994	Japan .

(List continued on next page.)

OTHER PUBLICATIONS

Hoffman, Steve and Stewart, Charles, "Text-based Routing: An Affordable Way Ahead?", Proceedings of the IEEE-IEE Vehicle Navigation & Information System Conference, Ottawa, Canada—VNIS 1993.

(List continued on next page.)

Primary Examiner—Brent A. Swarthout
Attorney, Agent, or Firm—Frank J. Kozak; Lawrence M. Kaplan

[57] **ABSTRACT**

The invention provides a method and system for providing route guidance and other information from a base unit to a remote unit in response to a request from the remote unit. A query is formatted at the remote unit, the query including the request, and is transmitted from the remote unit to the base unit. Requested route guidance information is calculated at the base unit in response to the query, using a large up-to-date database located at the base unit. A response to the query is formatted at the base unit, the response including route guidance information. The response is then transmitted from the base unit to the remote unit for display. The transmission is made in a compact form through the use of maneuver arms and combined maneuver arms and through the use of tokenized forms. A maneuver arm represents a road at an intersection, for depiction on a display, by one or two endpoint coordinates. The tokenized forms are expanded at the remote unit into textual driving instructions for each of one or more languages. In addition, the amount of information available at a remote unit can be increased by providing the remote unit with information from the base unit which is not adequately covered by any databases on-board the remote unit.

18 Claims, 15 Drawing Sheets

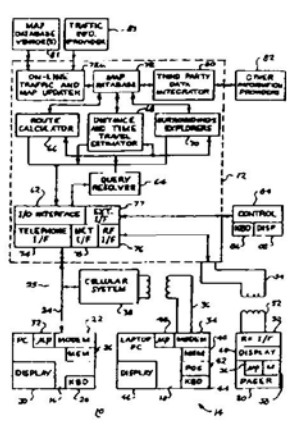

U.S. PATENT DOCUMENTS

4,758,959	7/1988	Thoonc et al. .	
4,780,717	10/1988	Takanabe et al.	340/995
4,812,843	3/1989	Champion, III et al.	340/905
4,819,174	4/1989	Furuno et al.	340/995
4,951,212	8/1990	Kurihara et al.	340/395
4,954,958	9/1990	Savage et al. .	
4,954,959	9/1990	Moroto et al.	340/995
4,974,170	11/1990	Bouve et al.	395/357
5,043,902	8/1991	Yokoyama et al.	340/988
5,067,081	11/1991	Person	340/995
5,113,178	5/1992	Yasuda et al.	340/995
5,126,941	6/1992	Gurmu et al.	340/989
5,172,321	12/1992	Ghaem et al.	340/995
5,187,810	2/1993	Yoncyama et al.	340/905
5,214,757	5/1993	Mauney et al.	395/161
5,243,528	9/1993	Lefebvre	340/995
5,262,775	11/1993	Tamai et al.	340/995
5,283,575	2/1994	Kao et al.	340/990
5,289,572	2/1994	Yano et al.	395/155
5,291,412	3/1994	Tamai et al. .	
5,291,413	3/1994	Tamai et al. .	
5,293,163	3/1994	Kakihara et al.	340/988
5,293,484	3/1994	Dabbs, III et al.	340/825.44
5,359,527	10/1994	Takanabe et al.	340/990
5,396,429	3/1995	Hanchett .	
5,406,490	4/1995	Braegas	340/905
5,406,493	4/1995	Goto et al.	340/995
5,424,951	6/1995	Nobe et al. .	
5,465,088	11/1995	Braegas	340/905
5,537,323	7/1996	Schulte .	
5,543,789	8/1996	Behr et al.	340/995
5,559,707	9/1996	DeLorme et al.	340/995
5,579,535	11/1996	Orlen et al.	340/995
5,614,895	3/1997	Ohomori et al.	340/995
5,699,255	12/1997	Ellis et al.	340/995

FOREIGN PATENT DOCUMENTS

WO 92/			
14215	8/1992	WIPO .	
WO 92/21001	11/1992	WIPO .	

OTHER PUBLICATIONS

PCT—Notification of Transmittal of the International Search Report, dated Nov. 2, 1995, in International application No. PCT/US95/07859, Application Shields Enterprises, Inc.
 "Smart cars. Smart Highways." Collier, W. Clay and Weiland, Richard J. *IEEE Spectrum*, Apr. 1994, pp. 27–33.

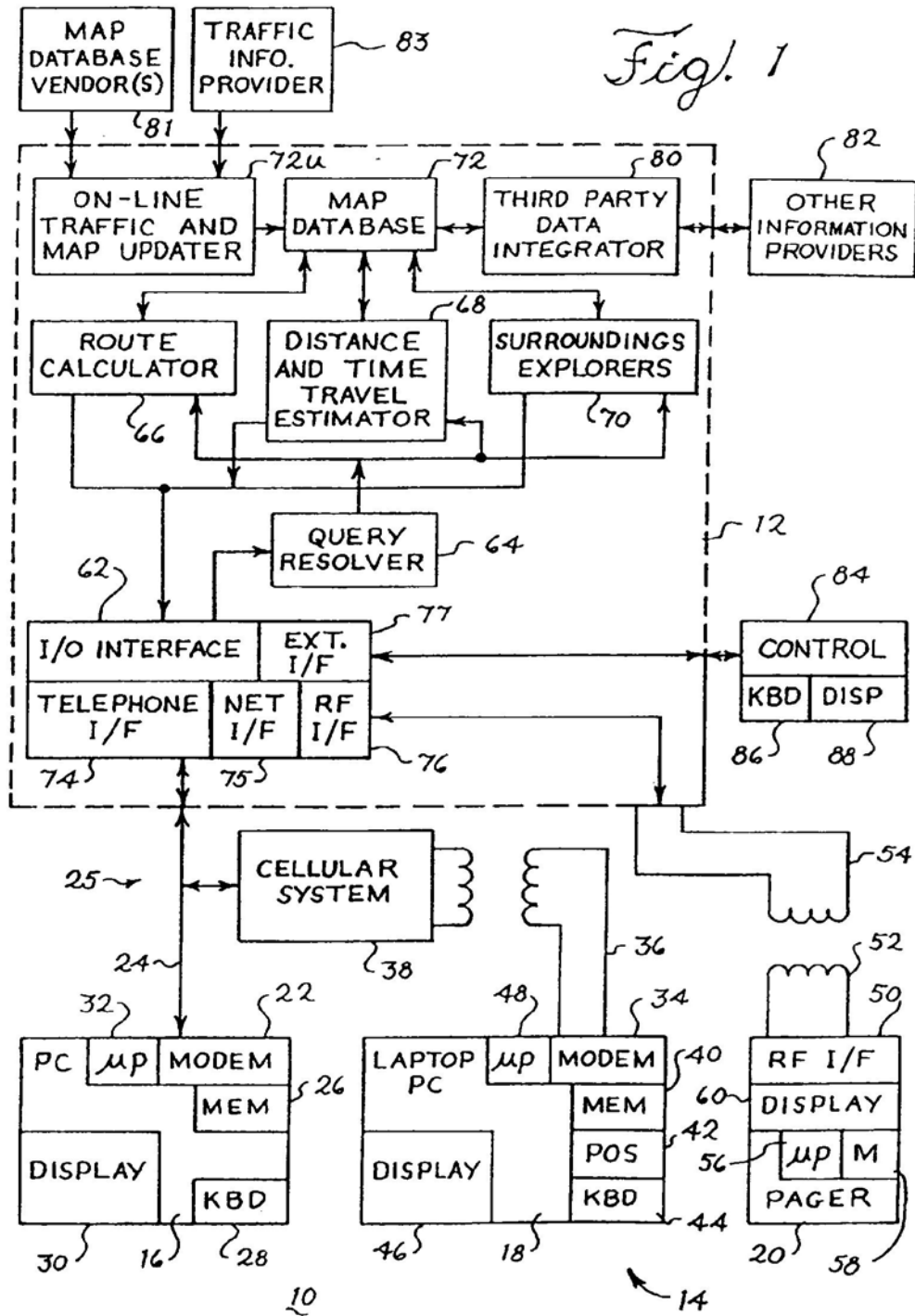

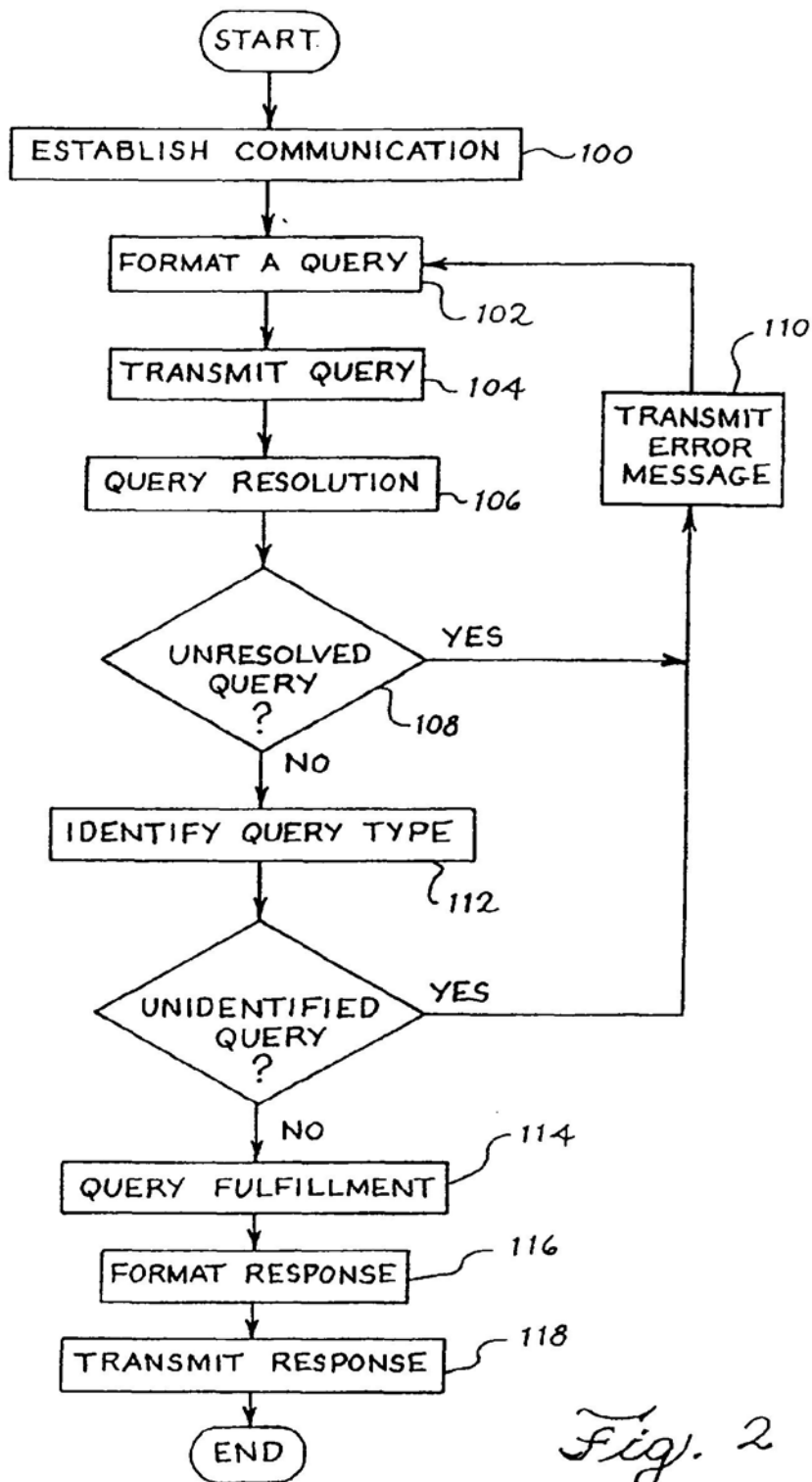

Fig. 2

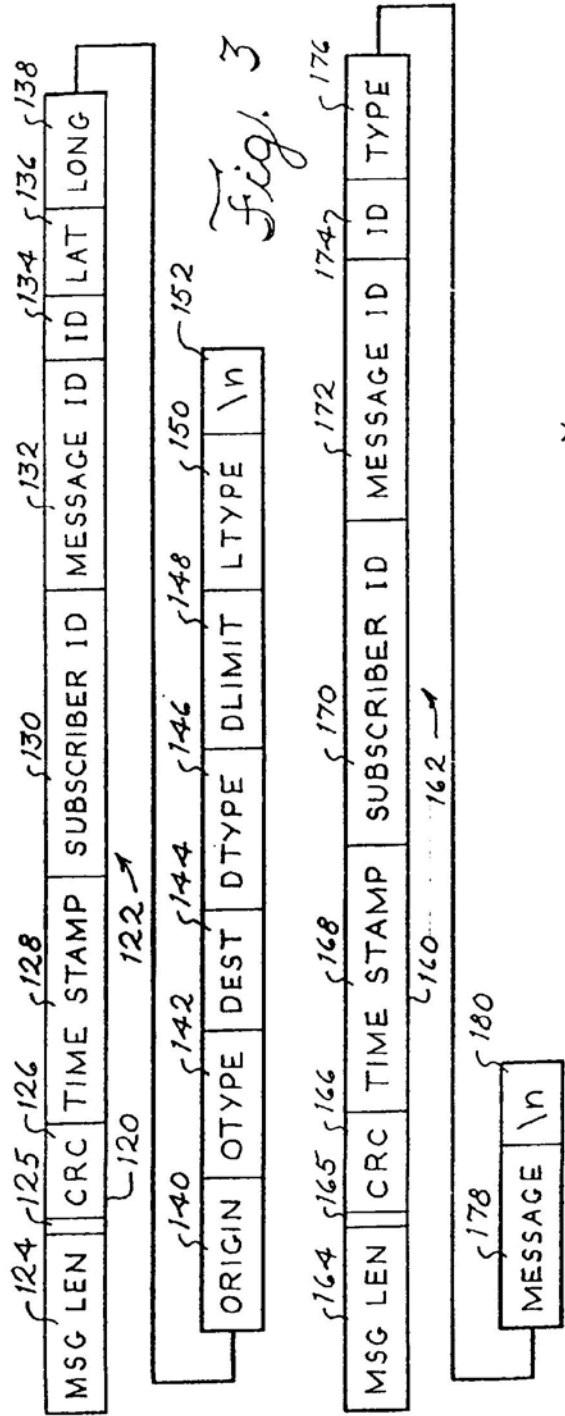

Fig. 3

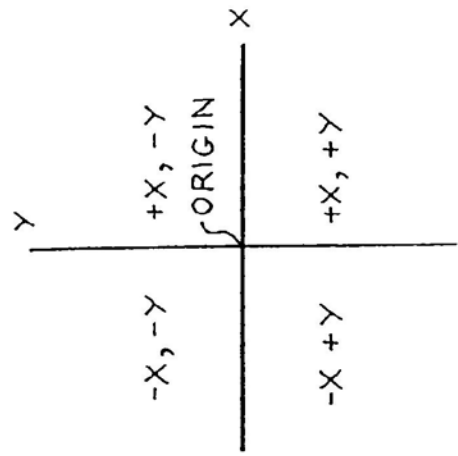

Fig. 5

Fig. 7

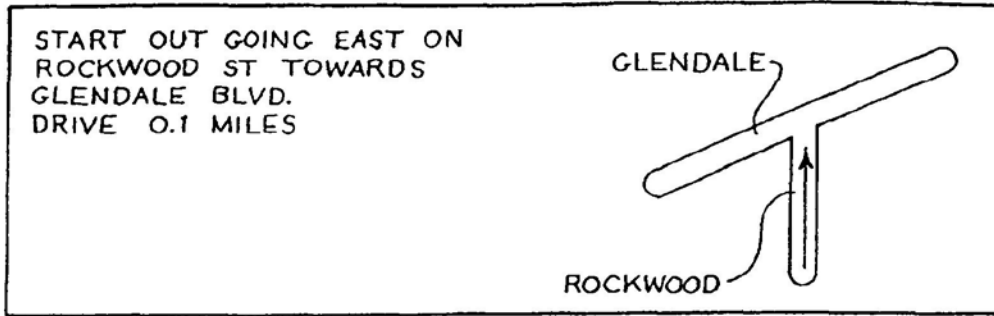

Fig. 6

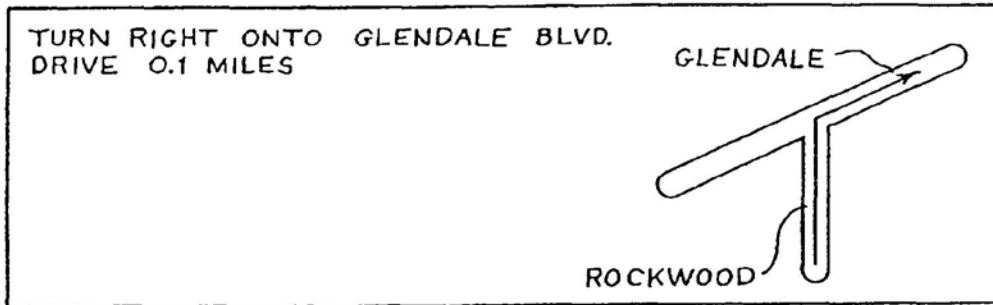
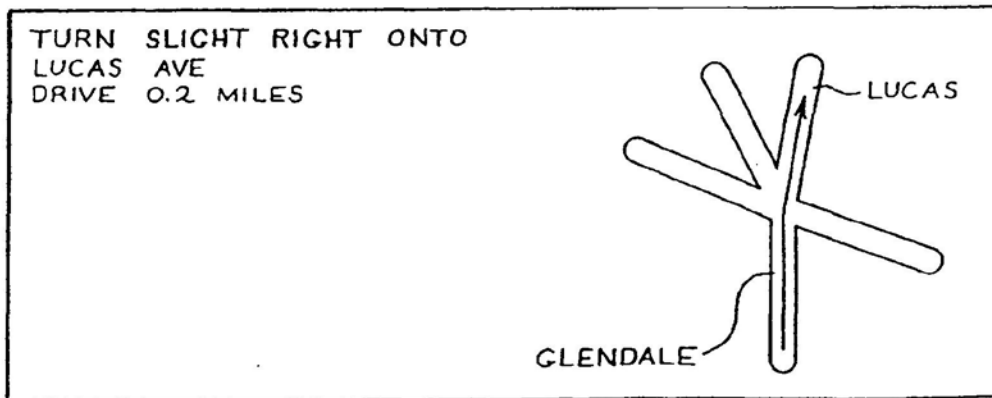

Fig. 7

Fig. 8



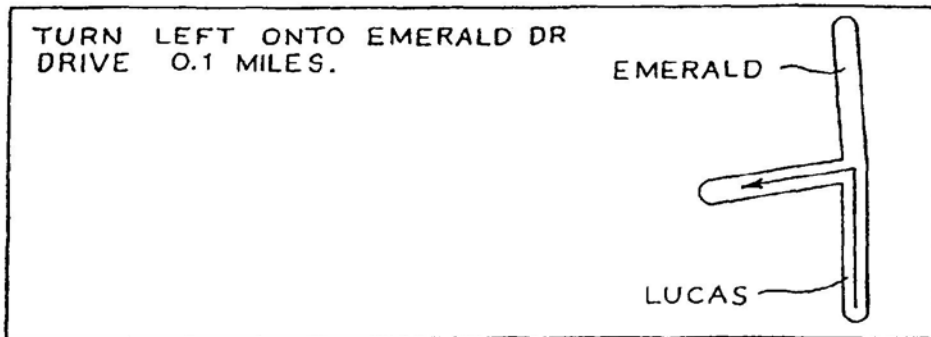

Fig. 9

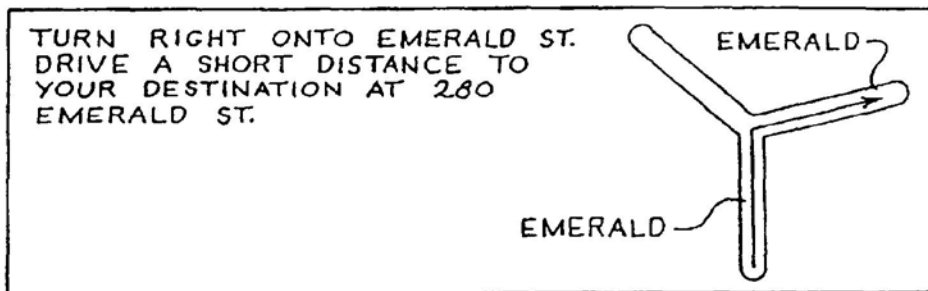
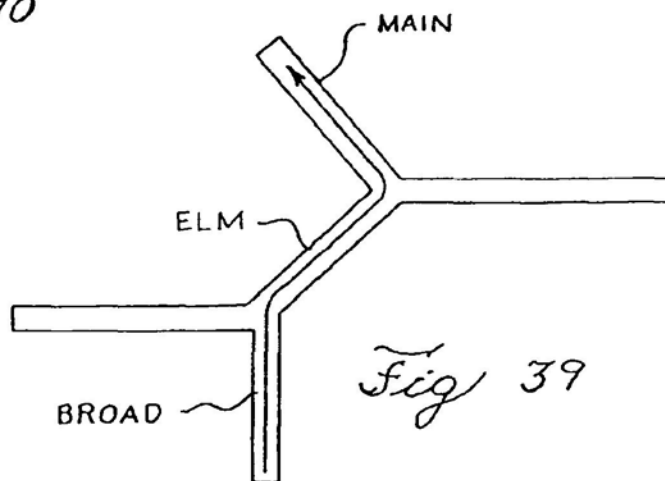

Fig. 10



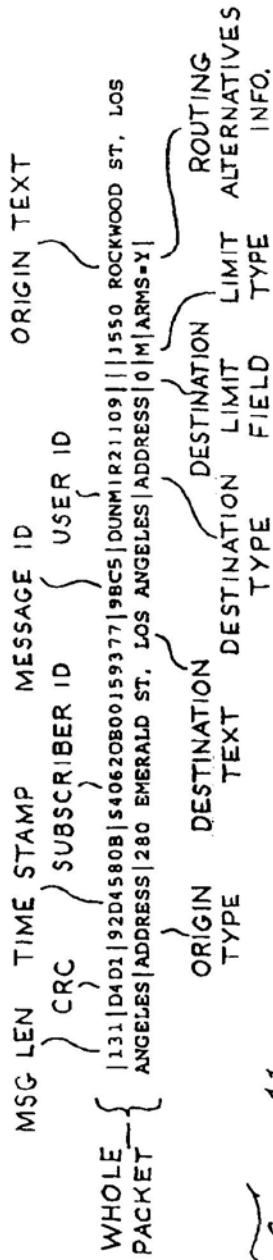
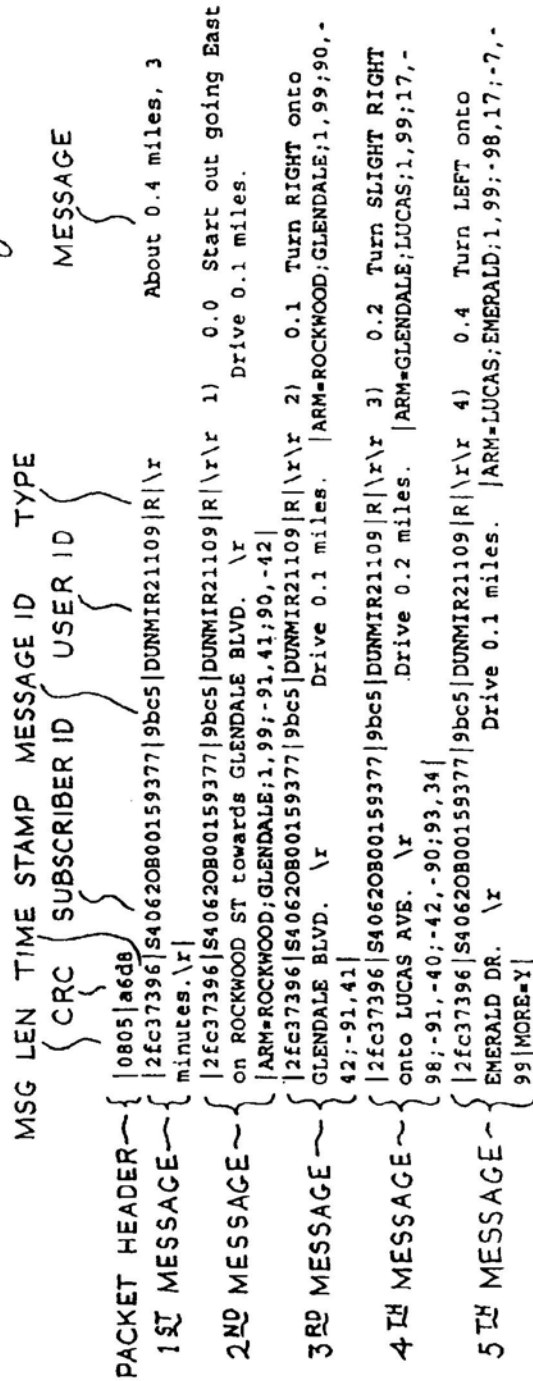

Fig. 11

Fig. 12



WHOLE PACKET~{ |073|2F39|92D45811|S40620B00159377|9BCA|DUNMIR21109| |||||MANEUVER=NEXT|ARMS=Y|

Fig. 13

Fig. 14

PACKET HEADER ~ { |0495|9588
 { |2fc3739b|S40620B00159377|9bca|DUNMIR21109|R|\r 5) 0.4 Turn RIGHT onto
 1ST MESSAGE~ { EMERALD ST. \r Drive a short distance to your destination at 280
 EMERALD ST.\r|ARM=EMERALD;EMERALD;1,99;96,-26;-74,-66|
 2ND MESSAGE~ { |2fc3739b|S40620B00159377|9bca|DUNMIR21109|R|\r Thank you for using
 SEI/EnRoute\r\rDatabase Copyright 1992 - 94 Navigation Technologies
 Corp.\r(Database version wsall0076_2.3.0, SEI/EnRoute Copyright 1993-1994 SEI
 Information Technology/IDS Software version 1.2)\r|MORE=N|

Fig. 15

|078|0A8D|80DC0960|IDSDIVISION|9D89|BOBD| |||||SESSION=00000000|BURST=N
MAXPKT=1024| ~

Fig. 16

|0039|67f1|2ef5d974|IDSDIVISION|9d89|BOBD|E|OK| ~

Fig. 17

|055|800B|80DC0962|IDSDIVISION|9D8B|BOBD|||||CONFIG=LA.CFG|~

Fig. 18

|0039|3d8a|2ef5d976|IDSDIVISION|9d8b|BOBD|E|OK|~

Fig. 19

|119|A4C8|80DC096E|IDSDIVISION|9D98|BOBD|||950 S FLINT RIDGE WAY,
ANAHEIM|ADDRESS|2043 N SACRAMENTO, ORANGE|ADDRESS|0|M|ARMS=Y|~

Fig. 20

|0753|2bc6|2ef5d987|IDSDIVISION|9d98|BOBD|R|\r About 9.1 miles
20 minutes.\r|~
|2ef5d987|IDSDIVISION|9d98|BOBD|R|\r 1) 0.0 Start out going
Northwest on S FLINT RIDGE WAY. \r Drive a short distance.
|ARM=FLINT RIDGE;WHITE FIR;1,99;-79,-61;24,-96|~
|2ef5d987|IDSDIVISION|9d98|BOBD|R|\r 2) 0.0 Turn LEFT onto E WHITE
FIR LN. \r Drive 0.1 miles. |ARM=FLINT RIDGE;WHITE FIR;1,99;
79,-61;24,-96|~
|2ef5d987|IDSDIVISION|9d98|BOBD|R|\r 3) 0.1 Turn RIGHT onto S LONE
PINE LN. \r Drive 0.1 miles. |ARM=WHITE FIR;LONE
PINE;1,99;67,-73|~
|2ef5d987|IDSDIVISION|9d98|BOBD|R|\r 4) 0.2 Turn LEFT onto E
SOMERSET LN. \r Drive a short distance. |ARM=LONE
PINE;SOMERSET;1,99;-93,-35;38,-92|MORE=Y|~

Fig. 21

|062|61D6|80DC0975|IDSDIVISION|9D9F|BOBD|||||MANEUVER=NEXT|ARMS=Y|~

|062|1595|80DC097B|IDSDIVISION|9DA5|BOBD|||||||MANEUVER=NEXT|ARMS=Y|~

Fig. 25

|0640|638b|2ef5d990|IDSDIVISION|9da5|BOBD|R|\r|13) 9.0 Turn RIGHT
onto E BRENTFORD AVE. \r Drive 0.1 miles.
|ARM=BRECKENRIDGE;BRENTFORD;1,99;99,-4;-4,-99|~
|2ef5d990|IDSDIVISION|9da5|BOBD|R|\r|14) 9.0 Turn LEFT onto N
SACRAMENTO ST. \r Drive a short distance to your destination
at 2043 N SACRAMENTO ST.\r|ARM=BRENTFORD;SACRAMENTO;1,99;-99,0|~
|2ef5d990|IDSDIVISION|9da5|BOBD|R|\r Thank you for using
SEI/EnRoute!\r\rDatabase Copyright 1992 - 94 Navigation Technologies
Corp.\r(Database version la0104_2.3.0, SEI/EnRoute Copyright 1993-1994
SEI Information Technology/IDS Software version 5.48)\r|MORE=N|~

Fig. 26

|121|7372|80DC099C|IDSDIVISION|9DC6|BOBD|||1750 QUEENS RD, LOS
ANGELES|ADDRESS|7530 ORANGETHORPE, BUENA PARK|ADDRESS|0|M|ARMS=Y|~

Fig. 27

Fig. 28

```

|0746|fef2|2ef5d9b8|IDSDIVISION|9dc6|BOBD|R|\r      About 30.2
miles, 51 minutes.\r|^
|2ef5d9b8|IDSDIVISION|9dc6|BOBD|R|\r|r 1) 0.0 Start out going
Northwest on QUEENS RD towards FRANKLIN AVE. \r      Drive a short
distance. |ARM=QUEENS;QUEENS;1,99;-64,76|^
|2ef5d9b8|IDSDIVISION|9dc6|BOBD|R|\r|r 2) 0.1 Turn SLIGHT RIGHT onto
QUEENS RD. \r      Drive 0.5 miles. |ARM=FRANKLIN;QUEENS;1,99;4,-
99;95,-30|^
|2ef5d9b8|IDSDIVISION|9dc6|BOBD|R|\r|r 3) 0.5 Turn LEFT onto W SUNSET
BLVD. \r      Drive 3.5 miles. |ARM=QUEENS;SUNSET;1,99;-99,5;99,-
6|^
|2ef5d9b8|IDSDIVISION|9dc6|BOBD|R|\r|r 4) 4.1 Turn RIGHT onto the US-
101 SOUTH RAMP. \r      Drive 24.5 miles. |ARM=SUNSET;US-101
SOUTH;1,99;92,-37;-2,-99|MORE=Y|^

```

Fig. 29

```

|062|EB9C|80DC09A6|IDSDIVISION|9DD0|BOBD|||||MANEUVER=NEXT|ARMS=Y|^

```

|0802|db71|2ef5d9bb|IDSDIVISION|9dd0|BOBD|R|\r\r 5) 28.6 Take the KNOTT
 AVE exit. \r Drive 0.1 miles. |ARM=SANTA ANA;ARTESIA
 BLVD;1,99;77,-63;12,-99|\r
 |2ef5d9bb|IDSDIVISION|9dd0|BOBD|R|\r\r 6) 28.7 Merge onto KNOTT AVE.
 \r Drive 1.0 miles. |ARM=ARTESIA BLVD;KNOTT;1,99;19,-98;-
 23,97;-97,-21;97,22|\r
 |2ef5d9bb|IDSDIVISION|9dd0|BOBD|R|\r\r 7) 29.7 Turn LEFT onto
 ORANGETHORPE AVE. \r Drive 0.5 miles to your destination at
 7530 ORANGETHORPE AVE.\r|ARM=KNOTT;ORANGETHORPE;1,99;-99,3;-4,-99;99,-1|\r
 |2ef5d9bb|IDSDIVISION|9dd0|BOBD|R|\r Thank you for using
 SEI/EnRoute!\r\rDatabase Copyright 1992 - 94 Navigation Technologies
 Corp.\r(Database version la0104_2.3.0, SEI/EnRoute Copyright 1993-1994
 SEI Information Technology/IDS Software version 5.48)\r|MORE=N|\r

Fig. 30

|104|5F31|80DC09DF|IDSDIVISION|9E08|BOBD|||1855 W KATELLA AVE,
 ORANGE|ADDRESS|HAPPY|RESTAURANT|100|M|QUERY=POIS|\r

Fig. 31

|0085|30dd|2ef5d9f4|IDSDIVISION|9e08|BOBD|Q|No of POIs found:00000: : : -
 - - - : : |MORE=N|\r

Fig. 32

|105|E9C4|80DC09F6|IDSDIVISION|9E20|BOBD||1855 W KATELLA AVE,
ORANGE|ADDRESS|HUNGRY|RESTAURANT|100|M|QUERY=PCIS|~

Fig. 33

|0269|523a|2ef5da0c|IDSDIVISION|9e20|BOBD|Q|No of POIs found:00002: : : -
- , , : : ;HUNGRY TIGER SEAFOOD RESTAURANT:6231 MANCHESTER BLVD, BUENA
PARK:36:23606:0-0-223-137,4,1:46646:N;HUNGRY BEAR RESTAURANT:2219 N HARBOR
BLVD, FULLERTON:36:24034:0-0-459-108,4,2:38570:N|MORE=N|~

Fig. 34

|105|F245|80DC0A07|IDSDIVISION|9E31|BOBD||1855 W KATELLA AVE,
ORANGE|ADDRESS|BURGER|RESTAURANT|100|M|QUERY=POIS|~

Fig. 35

|0704|1c86|2ef5da1d|IDSDIVISION|9e31|BOBD|Q|No of POIs found:00016: : : -
- , , : : ;BREA'S BEST BURGERS:707 S BREA BLVD, BREA:36:23589:0-0-230-
190,4,1:38608:N;BURGER KING:959 S COAST DR, COSTA MESA:36:23729:0-0-395-
82,4,1:43298:N;BURGER KING:19201 BROOKHURST ST, HUNTINGTON
BEACH:36:24237:0-0-779-194,4,2:51444:N;BURGER KING:1236 W IMPERIAL HWY, LA
HABRA:36:24406:0-0-453-165,4,2:49052:N;C AND J BURGER:421 E LA HABRA BLVD,
LA HABRA:36:24408:0-0-229-139,4,1:50512:N;GEORGE'S BURGERS:601 W LA HABRA
BLVD, LA HABRA:36:24429:0-0-908-180,4,1:52112:N;IMPERIAL BURGERS:241 E
IMPERIAL HWY, LA HABRA:36:24435:0-0-919-268,4,-:46502:N;T AND S BURGER:650
W LA HABRA BLVD, LA HABRA:36:24484:0-0-908-180,4,2:52112:N|MORE=Y|~

Fig. 36

|055|ASC1|80DCOA0B|IDSDIVISION|9E34|BOBD|||||MANEUVER=NEXT|~

Fig. 37

|0643|833e|2ef5da1f|IDSDIVISION|9e34|BOBD|Q|IN-N-OUT BURGER:7926
VALLEY VIEW ST, LA PALMA:36:24514:0-0-1210-243,4,2:50592:N;BURGER
KING:245 N CITRUS ST, ORANGE:36:26021:0-0-829-124,4,1:6189:N;IN-N-
OUT BURGER:825 W CHAPMAN AVE, PLACENTIA:36:26314:0-0-959-
137,4,1:24590:N;BURGER KING:2850 S BRISTOL ST, SANTA
ANA:36:26542:0-0-396-111,4,1:36418:N;BURGER KING:601 E DYER RD,
SANTA ANA:36:26543:0-0-797-207,4,1:35830:N;BURGER KING:13431
NEWPORT AVE, TUSTIN:36:26864:0-0-871-69,4,1:28304:N;BOB'S
BURGER:13891 BEACH BLVD, WESTMINSTER:36:27177:0-0-199-
315,4,2:40114:N;IN-N-OUT BURGER:6292 WESTMINSTER BLVD,
WESTMINSTER:36:27186:0-0-1197-216,4,2:49140:N|MORE=N|~

Fig. 38

TOKEN	ENGLISH TABLE	SPANISH TABLE	GERMAN TABLE
1	MAKE A U TURN AT ____.	HAGA UNA VUELTA EN U EN ____.	AN DER KREUZUNG MIT ____ BITTE EINE KEHRTWENDUNG MACHEN.
2	____ CHANGES NAME TO ____.	____ CAMBIA EL NOMBRE A ____.	____ ÜNDERT DEN NAMEN ZU ____.
3	TURN LEFT ON ____ AND DRIVE ____ MILES.	DÉ VUELTA A LA IZQUIERDA EN ____ Y MANEJE ____ MILLAS.	AUF ____ LINKS ABBIEGEN UND ____ MEILEN WEITERFUHREN.

Fig. 40

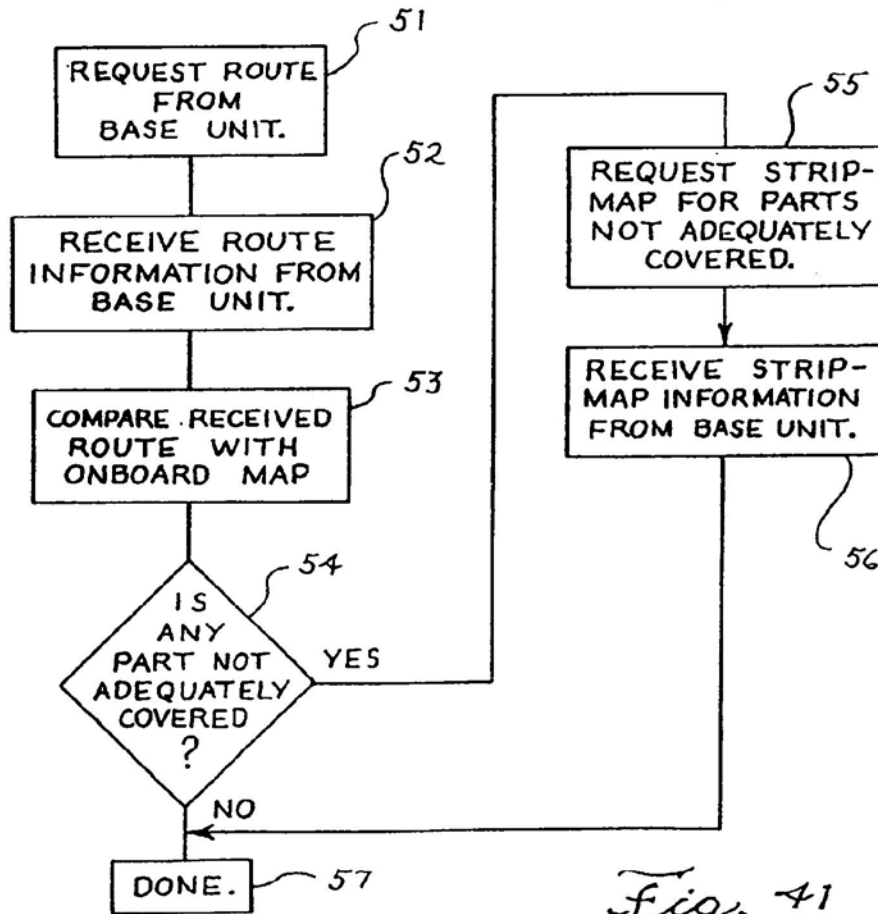

Fig. 41

ELECTRONIC NAVIGATION SYSTEM AND METHOD

REFERENCE TO RELATED APPLICATIONS

The present application is a continuation of Ser. No. 08/494,198, filed Jun. 23, 1995, now U.S. Pat. No. 5,808,566, which was a continuation-in-part of Ser. No. 08/265,094, filed Jun. 24, 1994, now U.S. Pat. No. 5,543,789, the entire contents of which are incorporated by reference herein.

REFERENCE TO MICROFICHE APPENDIX

Included with this specification is a microfiche appendix including 3 sheets of 283 total frames.

A portion of the disclosure of this patent document contains material which is subject to copyright protection. The copyright owner has no objection to the facsimile reproduction by anyone of the patent document or the patent disclosure, as it appears in the Patent and Trademark Office patent file or records, but otherwise reserves all copyright rights whatsoever.

BACKGROUND OF THE INVENTION

The invention relates generally to a system and method for providing route guidance and tracking information and other information from a base unit to a mobile unit over wireless, wireline, or optical devices.

The invention more particularly relates to an apparatus and method for providing to a mobile unit route guidance and tracking information and other information which has been calculated and/or stored at a base unit in response to a query from the mobile unit.

Systems have already been developed which provide geographical or position-dependent information to a mobile user. Such systems are generally installed in an automobile or other vehicle. These systems generally include an on-board geographic database which may be accessed to determine geographic information, such as locations of points of interest, directions to points of interest, and directions between a specified origin and a destination. An on-board computer calculates route guidance information using data from the database in response to user inputs.

Such systems are known as autonomous route guidance systems since they are independent and self-contained. The systems generally include a geographic database, positioning sensors, and a computer including a keyboard and display. The geographic database is a representation of a region or metropolitan area and may include, for example, street names, navigation attributes, such as turn restrictions and one-way streets, street addresses, and points of interest, such as airports, restaurants and museums. The positioning sensors may determine geographic position from RF (Radio Frequency) triangulation or in response to signals from, for example, GPS (Global Positioning System), LORAN C or other similar positioning systems, and from motion and direction detectors. The computer calculates route guidance information in response to inputs from the other system components as well as from operator input. The route guidance information is provided to the user in the form of navigational text or map graphics.

Autonomous route guidance systems have many drawbacks, however, which have prevented their widespread use. Because the system is autonomous and has an on-board database, the system must include large storage capabilities for storing all of the data which form the

database. Technologies such as CD-ROM have allowed storage of an entire database but require still a tradeoff between cost and fast, efficient data access.

Another problem with autonomous route guidance systems is maintenance and currency of the database. As new streets are built, or as old streets are reconfigured, as businesses and other points of interest open and close, the database on CD-ROM or other media becomes out of date. In addition, when a database is compiled, it may include errors which are then replicated in the many copies provided to users. These errors may require correction in the user copies by replacing those database copies. Moreover, incorrect or outdated information in the database can lead to errors when calculating routes. When an out-of-date database does not include the information that a particular roadway is closed, the system may be unable to calculate an alternate route.

Autonomous route guidance system providers may improve the accuracy of the system by providing occasional database updates to users. However, distribution of the database, in a medium such as CD-ROM or floppy disk, to remotely located mobile users may be difficult. In addition, the media themselves are expensive since they may generally be used only a single time.

Other aspects of such prior art autonomous route guidance systems add to their cost and inconvenience. Because the systems are autonomous, they must include all components, including the computer, the database and the position sensor. Using present technology, such a system is too heavy and too large to be readily transported by an individual. In addition, the complete system has power requirements which make battery operation impractical. As a result, autonomous route guidance systems have been limited to installation in automobiles or other vehicles which can accommodate the size and power requirements of such a system. The current best price for a complete autonomous route guidance system is substantial. This includes only the cost for a single, dedicated autonomous route guidance system.

Another type of route guidance system has been tested in Europe using beacons to provide a guidance signal to on-board equipment. The system directs the user to travel from beacon to beacon, creating a stepwise path between an origin and a destination because of the fixed locations of the beacons. The navigational information thus provided forms a generally inefficient routing path from origin to destination. In addition, such a system does not provide the capability to query a database for information about nearby points of interest and other geographical information.

Therefore, there is a need for a routing and information system that continually provides access to up-to-date, correct geographic information by a remote user. There is a further need for a routing and information system which can be implemented on lightweight, portable devices for easy, convenient transportation and use. There is a further need for a routing and information system which is independent of any particular hardware configuration and which may be implemented on any suitably equipped data processing apparatus, such as a desktop personal computer, a laptop computer, a personal digital assistant or even a pager. There is a further need for a routing and information system which provides communication between mobile units and a base unit over any available channel, including wireless, wireline, and optical channels. There is a still further need for a data communication protocol for providing accurate, reliable communication in such a system, independent of hardware configuration and in a compact form.

SUMMARY OF THE INVENTION

An object of the invention is to provide a method and system for transmitting route guidance and other information from a base unit to a remote unit in a compact form.

Another object of the invention is to provide a method and system for transmitting route guidance and other information from a base unit to a remote unit in a language independent form such that the remote unit can provide the information to a user in any language or form desired by the user at the remote unit.

Another object of the invention is to provide a method and system for transmitting route guidance and other information from a base unit to a remote unit in which the amount of information available at a remote unit can be expanded by providing the remote unit with information from the base unit which is not adequately covered by any databases on-board the remote unit.

The invention provides a method and system for providing route guidance and other information from a base unit to a remote unit in response to a request from the remote unit. A query is formatted at the remote unit, the query including the request, and is transmitted from the remote unit to the base unit. Requested route guidance information is calculated at the base unit in response to the query, using a large up-to-date database located at the base unit. A response to the query is formatted at the base unit, the response including route guidance information. The response is then transmitted from the base unit to the remote unit for display.

The transmission is made in a compact form through the use of maneuver arms and combined maneuver arms and through the use of tokenized forms. These tokenized forms represent a large amount of textual information by one or several alphanumeric characters.

A maneuver arm represents a road at an intersection, for depiction on a display, by one or two endpoint coordinates. If two intersections are sufficiently close together, a first set of maneuver arms for one intersection and a second set of maneuver arms for the other intersection are combined to produce a combined set of endpoints for transmission in a compact form to depict the first set of maneuver arms and the second set of maneuver arms on a common display.

The tokenized forms are expanded at the remote unit into textual driving instructions for each of one or more languages. In addition, the amount of information available at a remote unit can be increased by providing the remote unit with information from the base unit which is not adequately covered by any databases on-board the remote unit.

Other objects, features, and advantages of the invention will be apparent from the detailed description set forth below.

BRIEF DESCRIPTION OF THE DRAWINGS

The features of the invention are set forth with particularity in the appended claims. The invention, together with further objects and advantages thereof, may be further understood by making reference to the following description taken in conjunction with the accompanying drawings, wherein:

FIG. 1 is a functional block diagram illustrating a system of the invention;

FIG. 2 is a flow diagram illustrating a method of the invention;

FIG. 3 is a diagram illustrating a data communication protocol for communicating data from a mobile, or remote,

unit to a base unit in accordance with the invention and which is used in conjunction with the system of FIG. 1 and the method of FIG. 2;

FIG. 4 is a diagram illustrating a data communication protocol for communicating data from a base unit to a mobile unit in accordance with the invention and which is used in conjunction with the system of FIG. 1 and the method of FIG. 2;

FIG. 5 is a diagram illustrating a suitable sign convention for maneuver arm endpoint coordinates;

FIGS. 6 to 10 show examples of maneuver arms displays in a remote unit;

FIGS. 11 to 14 illustrate data that is transferred between a remote unit and a base unit in the example of FIGS. 6 to 10;

FIGS. 15 to 38 illustrate additional examples of data transferred between a remote unit and a base unit;

FIG. 39 illustrates a combined maneuver arms display; FIG. 40 illustrates some examples of tokens and corresponding expanded English, Spanish, and German text; and FIG. 41 is a flowchart used for explaining operation of a stripmap request feature of the invention.

DETAILED DESCRIPTION OF PREFERRED EMBODIMENTS

Overview

The invention provides a method of providing route guidance information and other information from a base unit to a mobile unit in response to a request from the mobile unit. The method comprises the steps of formatting a query at the mobile unit, the query including the request, communicating the query from the mobile unit to the base unit, and calculating route guidance information at the base unit in response to the query. The method further comprises the steps of formatting a response to the query at the base unit, the response including route guidance information, and communicating the response from the base unit to the mobile unit. The guidance information may include navigation instructions from an origin to a destination, information about one or more points of interest within a particular region, or other geographically referenced information.

The invention further provides a system for communicating routing information between a base unit and a mobile unit. The system comprises an input means at the mobile unit for providing an origin and a destination. The system further comprises a calculating means at the base unit for calculating a route between the origin and the destination. The system still further comprises communication means for communicating the origin and the destination from the mobile unit to the base unit and for communicating the route from the base unit to the mobile unit. The routing information may include navigation instructions from an origin to a destination, information about one or more points of interest within a particular region, or other geographically referenced information.

The invention still further provides a method of providing routing information to a mobile unit. The method comprises the steps of providing an origin and a destination from the mobile unit to a base unit, the base unit located remotely from the mobile unit. The method further comprises the steps of calculating at the base unit a route between the origin and the destination, and providing the route to the mobile unit.

The invention still further provides a system for providing route guidance information to a remote location from a central location. The system comprises a mobile unit includ-

5

ing an input means for providing at least a route destination and an output means for providing an indication of the route guidance information. The system further comprises a first transmission means at the mobile unit for transmitting destination data and origin data from the mobile unit, the destination data being indicative of a route destination and the origin data being indicative of a route origin. The system still further comprises a base unit at the central location. The base unit includes a first receiving means for receiving the destination data and the origin data from the first transmission means, a calculating means coupled with the receiving means for calculating a route to the route destination from a route origin responsive to the destination data and the origin data, and a second transmission means for transmitting routing data, the routing data being indicative of the route. The system still further comprises a second receiving means at the mobile unit for receiving the routing data from the second transmission means, the second receiving means being coupled with the output means for providing the route guidance information to the input means responsive to the routing data.

The invention also provides a system and method for providing geographically referenced information from a base unit or server to a mobile unit. The mobile unit may be a transportable device such as a laptop computer or personal digital assistant (PDA), or may be a desktop personal computer or any other device permitting data entry and display, printing, or sounding of the provided information.

The mobile unit communicates with the base unit using any available communication system, such as land line telephone link, cellular telephone or radio frequency transmission. Queries are communicated from the mobile unit to the base unit. The query requests route guidance information, information about a point of interest or other geographical information. The query is formatted in a specified protocol. The base unit communicates responses to queries, the responses also being formatted in a specified protocol. The responses may include, for example, textual navigational directions and/or maneuver arms showing graphical representations of street intersections and the calculated route through the intersection. Transmitting only a representation of the intersection, rather than all geographical features around the intersection, allows the response, including the maneuver arms, to be transmitted over a low bandwidth channel. The invention operates independently of the communication system and is adaptable to any system. The invention allows support for many different mobile unit platforms, taking advantage of each platform's capabilities while retaining as much system-level look and feel consistency as possible.

The base unit includes a geographical database, such as the Navigation Technologies Corp. navigable map database. The geographical database stores a variety of geographical and position-oriented attributes, such as street addresses, turn restrictions and points of interest. The points of interest are preferably organized according to different parameters, including point of interest type, such as "restaurant" or "museum;" point of interest name; city; driving distance; and/or driving time. The base unit further includes a server for receiving queries from one or more mobile units, resolving ambiguities in the queries, determining a response to a query, and accessing the geographical database as needed. The server formats a response to the query and communicates the response to the mobile unit.

In a first mode of operation, an origin and a destination are entered at the mobile unit. The origin and/or the destination may be in the form of a street address, an intersection of two

6

streets, or a point of interest previously identified in the geographical database. The origin and destination are communicated from the mobile unit to the base unit. The base unit calculates a route between the specified origin and destination. The routing information is communicated from the base unit to the mobile unit where it is displayed by the mobile unit. The display can be a graphical display, showing map portions and providing travel directions along with a display of highway signs and other information. The display can include textual information providing travel directions. The mobile unit may supply a digitally synthesized voice which audibly presents the travel directions to the user. In some applications, the display is stylized to display additional information to the user or to display information in a more realistic or more informative form.

For example, the display can indicate in graphical form whether an on or off ramp is a tight or gentle turn by displaying stylized ramps. Shapepoints, that is, points which more accurately depict the physical shape of a road, can be generated either by the base unit or by a remote unit.

In a second mode of operation, the mobile unit formulates a query requesting information about points of interest within a specified distance of an origin. The origin may be specified by street address, intersecting streets, by geographic position or by reference to a point of interest. The query is communicated from the mobile unit to the base unit. The base unit uses the geographical database to formulate a response. The response is communicated from the base unit to the mobile unit for display to the user.

In a third mode of operation, a mobile unit provides information specifying its location to the base unit. A control unit requests tracking information about the mobile unit from the base unit. The control unit may be, for example, another personal computer, coupled to the base unit through an external interface, either directly or through a communications network. The base unit provides to the control unit tracking information including the current location of the mobile unit with respect to the street network and the route covered by the mobile unit.

The invention further provides a protocol for communicating a query from the mobile unit to the base unit and for communicating a response from the base unit to the mobile unit. The protocol allows transmission of variable length messages, as required by the individual mobile unit or communication link. The protocol includes error checking, time stamping and subscriber information.

The protocol further includes information specifying origin and destination, for a query, and message type and message contents, such as route information, for a response.

The invention thus provides geographically referenced information from a base unit to a mobile unit, the mobile unit needing only data entry and display devices and a communications link. An advantage of the invention is that the invention provides this capability in a mobile unit which does not require on-board database storage or position finding equipment at the mobile unit.

A further advantage of the invention is that the invention provides a mobile unit with access to a larger, more comprehensive database. For example, prior art CD-ROM-based databases are limited to 600 MB of storage which may be sufficient to store map information for only a single metropolitan region. In contrast, the invention allows the mobile unit to access map information for many metropolitan regions or an entire nation, as well as other information, such as on-line yellow page information or news, weather and/or traffic advisory information, which may be provided by third-party information providers. Such information can be

provided on a geographic specific basis. A still further advantage of the invention is that the invention permits automatic, real time database updates by maintaining the database only at the base unit, avoiding the need to distribute database updates to the mobile units.

A further advantage of the invention is that the invention provides a method for communicating requests for routing information and responses including routing information in which the method is independent of specific hardware. A further advantage of the invention is providing a system which can be implemented using any commonly available hardware devices, including laptop computers, personal digital assistants and other transportable units communicating via wireless, wireline, and/or optical systems.

A still further advantage of the invention is efficiently conveying complex information, including graphical information, over communication channels having a limited bandwidth using data compression and a novel protocol, to be described in detail below. This allows a system in accordance with the invention to dynamically transmit selected map portions for display on a capable mobile unit. The geographical information may be saved at the mobile unit for later retrieval and display, without having to again access the base unit.

System Description

FIG. 1 is a functional block diagram of a system 10 embodying the invention. The system 10 includes a base unit 12 and a plurality 14 of remote units arranged to communicate with the base unit 12. The base unit 12 includes a central processing unit (CPU) and a program memory which stores programs for performing the functions described below. IBM RS/6000 series computers are suitable for such a purpose; however, many other computer systems can be used. The plurality 14 of remote units may include, for example, a desktop personal computer (PC) 16 such as IBM compatible PCs and the Apple Newton, a laptop personal computer (PC) 18, or a pager 20. Suitable program languages include ANSI C and MS-Visual Basic.

The plurality 14 of remote units may include any number of mobile units. The base unit 12 is preferably located at a single, central location. One remote unit may be permanently located at a single site, such as desktop personal computer 16. Another remote unit may be mobile or transportable, such as laptop personal computer 18 or pager 20. As used herein, the term "mobile unit" includes both remote units which may be permanently located at a single site and remote units which are mobile or transportable.

Communications between the base unit and the remote units are packetized. A packet contains one or more messages.

The desktop personal computer 16 is an example of one type of mobile unit which may be included in the system 10. The desktop personal computer 16 preferably includes a modem 22, a memory 26, a keyboard 28, a display 30 and a microprocessor 32. The modem 22 is adapted to be coupled to a telephone line 24. The telephone line 24 is in turn coupled to the commercial telephone system 25. The modem 22 may be, for example, a serial (dial-up line) modem such as a modem compatible with an AT command set which is built into the desktop personal computer 16, a stand-alone modem, or a PCMCIA modem. Alternatively, the modem may be for use with a specialty wireless transmission network such as ARDIS, CDPD (cellular digital packet data) or RAM. Still further, the modem may be of a type custom designed for the desktop personal computer 16. The modem 22 forms a transmission means at the mobile unit for transmitting the origin and the destination and a

receiving means at the mobile unit for receiving the responses, including the route, from the base unit 12.

The microprocessor 32 responds to program instructions and data stored in the memory 26. To activate the system 10, a user manipulates the keyboard 28 to formulate a request. The request may, for example, seek the route between an origin and a destination. The keyboard 28 thus provides an input means at the mobile unit for providing an origin and a destination. The desktop PC 16, under control of a program of instructions stored in the memory 26, conveys the request over the telephone line 24 to the base unit 12. The base unit 12 formulates a response to the request and conveys the response over the telephone line 24 to the desktop PC 16. The response to the request is displayed on the display 30. The display 30 thus forms an output means at the mobile unit for providing an indication of the route provided in the response. In addition, the response may be stored in the memory 26 for later retrieval and display. The memory 26 thus provides a storage means at the mobile unit for storing the route communicated from the base unit.

The laptop personal computer 18 is another example of a mobile unit which can be used in the system 10. The laptop PC 18 includes a modem 34, a memory 40, a position locator 42, a keyboard 44, a display 46 and a microprocessor 48. The modem 34 is coupled to an antenna 36 for sending and receiving cellular telephone calls in conjunction with the cellular telephone system 38, which is a portion of the commercial telephone system 25. The modem 34 may be, for example, any of the modem types described in conjunction with the modem 22 of the desktop personal computer 16.

The microprocessor 48 operates in response to program instructions and data stored in the memory 40. The position locator 42 provides the geographical position of the laptop PC 18. For example, the position indicator 42 may perform radio frequency (RF) triangulation or may be responsive to GPS (Global Positioning System), LORAN C signals or other satellite positioning systems for providing latitude and longitude positioning information. The position locator 42 thus provides a position determining means for determining the geographical position of the mobile unit. The laptop PC 18, in response to the program instructions stored in the memory 40, provides a request over the commercial telephone system to the base unit 12. The request may be, for example, for the route between an origin and a destination. The origin may be specified either by manipulating the keyboard 44 or by providing the latitude and longitude information produced by the position locator 42. The base unit 12 provides a response to the request to the laptop PC 18. The response is displayed on the display 46.

The pager 20 provides another example of a remote unit which can be used in the system 10. The pager 20 includes an RF interface 50 coupled to an antenna 52 for receiving RF signals from an antenna 54 coupled to the base unit 12. The pager 20 further includes a microprocessor 56 responsive to program instructions and data stored in a memory 58. In response to information transmitted from the base unit 12 and received at the antenna 52, the microprocessor 56 displays information, such as geographical directions, on a display 60.

In another mode of operation, one mobile unit, such as the desktop personal computer 16, may track another mobile unit, such as the laptop personal computer 18, using the system 10. A user of the desktop personal computer 16 may manipulate the keyboard 28 to request route guidance information such as tracking information.

The request is transmitted over the telephone line 24 to the base unit 12. The base unit 12 formulates a response based

on the geographic position information provided by the position locator 42 of the laptop PC 18. The response is transmitted over the telephone line 24 to the desktop personal computer 16 for display on the display 30.

Thus, the system 10 provides geo-referenced information over, for example, wireless and wireline devices to mobile and remote users. It is understood that the communications technologies and the mobile units illustrated in FIG. 1 may be combined in ways other than those illustrated in FIG. 1. For example, the desktop personal computer 16 may include an RF interface such as the RF interface 50 of the page 20. Similarly, the modem 34 of the laptop PC 18 may be adapted for coupling directly to a telephone line such as telephone line 24. In addition, other types of mobile units, such as personal digital assistants (PDAs), may be included in the system 10. Moreover, mobile units may access the base unit indirectly by communicating directly with a third-party information provider, such as Prodigy™, which in turn conveys queries to and responses from the base unit 12. In accordance with the invention, the invention operates independently of particular hardware configurations of the plurality 14 of remote units and of the communications system.

The base unit 12 includes an I/O interface 62, a query resolver 64, a route calculator 66, a distance and time travel estimator 68, a surroundings explorer 70, a map database 72, an on-line traffic and map updater 72U, and a third-party data integrator 80. The I/O interface 62 includes a telephone interface 74 for coupling the base unit 12 to the commercial telephone system 25 including the telephone line 24. The I/O interface 62 further includes an RF interface 76 for coupling the base unit 12 with RF communication devices such as an antenna 54. The I/O interface 62 and the modem 22 thus provide a communication means for communicating an origin and a destination from the desktop personal computer 16 to the base unit 12 and for communicating a route from the base unit 12 to the desktop personal computer 16. The I/O interface 62, the modem 34 and the antenna 36 provide a communication means for communicating the origin and the destination from the laptop personal computer 18 to the base unit 12 and for communicating the route from the base unit 12 to the laptop personal computer 18.

The I/O interface 62 may further include a network interface 75 for coupling the base unit 12 to one or more wireless or wireline communication networks such as CDPD (cellular digital packet data), TCP/IP (transmission control protocol/Internet protocol), ARDIS or RAM. The I/O interface 62 may further include an external interface 77 for coupling the base unit 12 to a control unit 84. The control unit 84 provides an external link to the base unit 12 and may be, for example, a personal computer coupled over a wireless or wireline network or a directly connected terminal. The control unit 84 may include, for example, a keyboard 86 and a display 88. The control unit 84 may request tracking information about the location of one or more mobile units. For example, a mobile unit may be located in an armored vehicle transporting valuables along a specified route. The control unit may receive tracking information from the base unit and, if the mobile unit in the armored vehicle varies from the specified route by a predetermined amount, sound an alarm or trigger some other action.

The I/O interface 62, including the telephone interface 74 and the RF interface 76, provide a means for coupling the base unit 12 with communications media such as the commercial telephone system and other wireline and wireless devices. The I/O interface 62 thus receives queries from the plurality 14 of remote units and transmits the responses from the base unit 12 to the plurality 14 of remote units. The I/O

interface 62 therefore provides a receiving means at the base unit for receiving the origin and destination and a transmitting means at the base unit for transmitting the route to a mobile unit.

The query resolver 64 receives the request from the I/O interface 62. When a request is entered at one of the plurality 14 of remote units, a mistake may be made.

For example, in manipulating the keyboard 44 of the laptop personal computer 18, the user may have entered "O'HAIR," intending to enter "O'HARE," indicating O'Hare Airport. Other ambiguities may be in the format of the address provided, in the latitude and longitude of the position provided, or in the definition of cross streets.

The function of the query resolver 64 is to resolve such ambiguities in the query at the base unit 12 and convey the query for further processing.

After the query resolver, the query is routed to the route calculator 66. In a manner well known in the art, the route calculator 66 determines a route between a specified origin and destination using the map database 72. The map database 72 may be, for example, the navigable map database maintained by Navigation Technologies Corp. The map database 72 preferably includes an accurate, complete, and up-to-date representation of geographic information such as addresses, street names, navigation attributes (including turn restrictions, one-way streets, physical dividers, relative heights, freeway sign text, and so forth), as well as point of interest categories, such as parks, schools, hospitals, restaurants, and golf courses associated with the geographic information. The on-line traffic and map updater 72U receives updating information from map database vendor(s) 81 and traffic information providers 83 and maintains map database 72 current.

In determining the route, the route calculator 66 preferably takes into account routing restrictions such as toll road avoidance, turn restrictions at a specified time of day, and other restrictions. Such routing restrictions may be specified by an operator at the base unit 12 in response to a temporary condition or may be added to the map database 72 when the restrictions become nationally available. The route calculator 66 thus forms a calculating means at the base unit for calculating a route between the origin and the destination. The map database may be divided into geographic areas such as metropolitan areas. Providing the route calculation function in the base unit 12 reduces the data storage and data processing requirements for the remote units. In certain applications, however, it may be desirable to provide the remote units with a limited route calculation function.

After a route has been calculated, the route is conveyed from the route calculator 66 to the I/O interface 62. The I/O interface 62 formats a response to the query. The response includes the route guidance information determined by the route calculator 66. The I/O interface 62 then communicates the response from the base unit 12 to the mobile unit which originally requested the information.

If the query requests a distance or a time of travel, the query is forwarded to the distance and time travel estimator 68. The distance and time travel estimator 68, in response to the query and using the map database 72, formulates a response to the query. The response is conveyed from the distance and time travel estimator 68 to the I/O interface 62. The response is formatted at the I/O interface 62 and communicated from the base unit 12 to the mobile unit which originally requested the information.

If the query requests information about points of interest in the area surrounding an origin, the query is conveyed to the surroundings explorer 70. The surroundings explorer 70

11

provides an optimized method for searching for points of interest satisfying specified criteria or parameters such as time or distance. For example, the surroundings explorer 70 may locate all McDonald's™ restaurants within a specified driving distance or driving time of a specified origin, or it may locate the McDonald's™ restaurant nearest the specified origin. The origin and search parameters are specified in the query received from the mobile unit. In response to the query, the surroundings explorer 70 accesses the map database 72 and searches outward from the specified origin. The surroundings explorer 70 analyzes paths in the map database 72 over which a mobile unit, in a car for example, could legitimately travel. The surroundings explorer 70 examines the associated point of interest information for entries satisfying the specified search parameters. The surroundings explorer 70 thus determines which points of interest satisfy the query. The information is then conveyed from the surroundings explorer 70 to the I/O interface 62 and a response is formatted. The response is then communicated from the base unit 12 to the remote unit which requested the information.

The third-party data integrator 80 provides additional data such as on-line yellow pages information or news, weather, and/or traffic advisory information for responding to queries from a mobile unit. The additional data are preferably received from other information providers, illustrated in FIG. 1 as functional block 82.

The additional data may also be added directly to and located within the map database 72. The additional data may be supplied external to the base unit 12 via any known data communications network.

The functions performed by the base unit 12, as described above and illustrated in the functional block diagram of FIG. 1, are performed in a data processing system. The data processing system may be in one or more units and include a processor for executing program instructions, a memory for storage of the program instructions and data such as the map database 72. The data processing system further includes other equipment such as digital logic for implementing the I/O interface 62 for receiving queries and sending responses. The data processing system may include a display and a keyboard as an operator interface.

FIG. 2 is a flow diagram illustrating a method of the invention. The method begins at step 100 where communication is established between the mobile unit and the base unit 12. Performance of this step is largely dependent on the specific implementation of both the base unit 12 and the mobile unit. For example, with reference to FIG. 1, the desktop personal computer 16 would establish communications using the modem 22 to place a telephone call over the telephone line 24 to the base unit 12. The telephone interface 74 of the base unit 12 and the modem 22 would establish communication in a manner well known in the art. Similarly, the laptop personal computer 18 would establish communications with the base unit 12 by completing a telephone call through the cellular telephone system 38. However, the basic operation of the invention is independent of the particular hardware and communication channels employed.

The method continues at step 102, in which a query is formatted at the remote unit. The query is formatted in accordance with the protocol of the invention, to be described in further detail below in conjunction with FIG. 3. The query comprises a serial stream of data and control bits. The control bits, for example, identify the remote user originating the query. The data bits specify the precise request being made of the base unit. For example, the data bits may specify an origin point and a destination point, from

12

which the route calculator 66 (FIG. 1) of the base unit 12 is to calculate the route. Certain communications transport protocols, specific to the particular hardware implementation of the system 10, may prepend or append characters or other control bits to the control and data bits which form the query. For example, the modem 22 of the desktop PC 16 may include handshaking bits or signals to be used by the telephone interface 74 of the base unit 12 for processing the query. At step 104, the query is transmitted from the mobile unit to the base unit 12.

The method continues at step 106, where ambiguities in the query are resolved by the query resolver 64 (FIG. 1). Ambiguities may be in the form of spelling errors in the identification of an origin or a destination, an inconsistent latitude or longitude specification, and the like. At step 108, if the query resolver 64 cannot resolve the ambiguity, an error message may be communicated from the base unit to the remote unit at step 110, and the query must be repeated.

The method continues at step 112, where the query type is identified. The query may be one of several different types, including a route query, a point of interest query, a language query, or a metro area query.

A route query asks the base unit 12 to identify a route between a specified origin point and a specified destination point. A route query includes the origin and the destination. A point of interest query requests a list of points of interest which satisfy specified criteria. For example, a point of interest query might request a list of all restaurants of a specific type, such as McDonald's™, within a specified distance or a specified driving time of a specified origin. A language query requests a list of available languages for display of information at the mobile unit or specifies the language (such as English or Dutch) in which the routing information is to be displayed at the remote unit. Such language queries are not needed if the language independent mode (to be described below) is being used. A metro area query requests a list of available metropolitan areas or specifies the metropolitan area within the map database 72 (FIG. 1) to be used for responding to the query. For example, a query which has as its origin "77 W. Chestnut Street" in Chicago must specify the Chicago metropolitan area rather than, for example, the Cincinnati metropolitan area, in order to prevent confusion. If a query cannot be identified, an error message is generated at step 110 and the query must be repeated. After the query type has been determined at step 112, the query is routed to, for example, the route calculator 66, the distance and travel estimator 68, and/or the surroundings explorer 70 (FIG. 1) for processing.

The method continues at step 114, where the query is fulfilled. For example, if the query requested routing information between an origin and a destination, the route calculator 66, operating in conjunction with the map database 72, calculates a route between the origin and the destination. Similarly, if the query was a point of interest query, the surroundings explorer 70 will determine points of interest which satisfy the query.

The method continues at step 116, where the response to the query is formatted. The response is formatted in accordance with a data communications protocol to be described in detail in conjunction with FIG. 4. The formatted response includes control and data bits. The control bits specify information such as the mobile unit which initiated the request. The data bits specify the information, such as route guidance information, which fulfills the query. At step 118, the method concludes when the response is electromagnetically transmitted from the base unit 12 to the mobile unit.

Referring now to FIG. 3, it is a diagram illustrating a data communication protocol for communicating data from a

13

mobile unit to a base unit in accordance with the invention and which can be used in conjunction with the system of FIG. 1 and the method of FIG. 2. The protocol illustrated in FIG. 3 is defined by a communications syntax including variable message lengths, allowing as little or as much data transfer as necessary for the specific application requirement. In this implementation example, the protocol can be used across all communications systems, as long as the printable, seven-bit ASCII character set, plus the "newline" character (0x0A) can be transmitted by the communications system.

The transmitted character set consists of the principal ASCII character set plus the newline character.

To transmit bytes of data which do not fit in this character set, or for communication protocols which do not allow transmission of the newline character, an escape mechanism is provided to allow transmission of these characters. For communication in binary format, numeric fields or numeric values are transmitted using two's complement notation, in network byte order (most significant byte first, followed by bytes of decreasing significance). Floating point numbers are transmitted using the IEEE 64-bit double precision format, with the most significant byte transmitted first.

Only a single query message 120 is needed to transmit a query from a mobile unit to the base unit 12. This query message 120 provides for both current location tracking information as well as route calculation requests. The query message 120 includes a plurality of fields 122. Each field of the plurality 122 of fields is separated by a delimiter, preferably the vertical bar "|" (ASCII code 0x7C). The start of the query message 120 begins with a delimiter character. The end of each message is marked by a delimiter character immediately followed by a newline character (ASCII code 0x0A), represented in FIGS. 3 and 4 as "\n". Any characters between the ending newline character and the starting delimiter are preferably ignored by the base unit 12 and the mobile unit.

As noted, the query message 120 includes a plurality of fields 122. Some communications transport protocols may prepend or append characters for controlling communication of the message in accordance with the specific hardware implementation of the system 10.

The query message 120 includes a message length field 124. This field specifies the length of the query message 120. The message length field 124 may also include a compression marker 125 indicating the compression status of the message. For example, the compression marker 125 may take on a first value if the query message 120 is compressed using a current phrase compression table. The compression marker 125 may take on a second value if the query message 120 is compressed using the current dictionary (bit compression) table. The compression marker 125 may take on a third value if the query message 120 is compressed using the L-Z (Lev-Zempel) compression algorithm. And the compression marker 125 may take on a fourth value or simply not be present if the query message 120 is not compressed in any way.

The query message 120 further includes a cyclical redundancy check (CRC) field 126. This field is preferably the computed CRC-16 of the query message 120, starting with the delimiter following the CRC field 126 up to and including the ending newline, as actually transmitted (i.e., as compressed). The query message 120 further includes a time stamp field 128 which gives the number of seconds since the epoch (00:00:00 GMT Jan. 1, 1970) when this message was sent. Preferably, messages older than 20 minutes will be ignored when received by the base unit 12.

14

The query message 120 further includes a subscriber identifier field 130. The information provided in this field may be used for billing and audit information. The query message 120 further includes a message identifier field 132.

The characters in this field are used to tag response messages transmitted from the base unit 12 to the requesting mobile unit. The base unit 12 will place the characters in the message ID field 132 in any return message so that the mobile unit may determine what original message the base unit 12 is responding to. The query message 120 further includes an identifier field 134, which provides identification information uniquely identifying the mobile unit which transmitted the query message 120. The identification field 134 is used for tracking and communications addressing.

The query message 120 further includes a latitude field 136 and a longitude field 138. These fields specify the current position of the mobile unit by latitude and longitude, respectively. By default, the current latitude and longitude provide the origin for all routing requests, and also provide the position used for default tracking address translation.

The query message 120 further includes an origin field 140. The origin field 140 specifies the origin address for a routing information request. If this field is empty, the current position specified by the latitude field 136 and the longitude field 138 is used as the origin address. The query message 120 further includes an origin type field 142, which may be either an address or a point of interest category (such as "restaurant", "museum" or "airport") which is recognizable by the base unit 12.

The query message 120 further includes a destination field 144, which specifies the destination address if routing information is requested by the mobile unit from the base unit 12. If the destination field 144 is empty, then no route is calculated by the base unit 12. Instead, the message 120 is considered to be a tracking message only, merely providing the location of the mobile unit.

The query message 120 further includes a destination type field 146 which specifies the type of destination. For example, the destination may be an address or a point of interest category recognizable by the base unit 12. For example, the point of interest categories may include "restaurant", "airport", or "museum." As one example, the destination type field 146 may be "restaurant", and the destination field 144 may be "McDonald's™".

The query message 120 further includes a destination limit field 148. This field specifies a limit for point of interest searches. Such a search will be limited to the range specified by the value in the destination limit field 148 about the origin. For example, if the destination limit field 148 is empty or has a value 0, the base unit 12 preferably interprets this to indicate that the nearest point of interest satisfying the requirements specified by the destination field 144 and the destination type field 146 should be located. If the destination limit field 148 is non-zero, then the limit specified sets the maximum range searched for a matching point of interest. If no matching point of interest is in the range specified, a "no match" route error is returned.

The value of the destination limit specified in the destination limit field 148 depends on the limit type field 150. The limit type field 150 determines what unit of measurement is in the destination limit field. For example, the limit type field may take on a first value (for example "M") when the destination limit specifies a straight line distance. The limit type field 150 may take on a second value when the destination limit is driving distance. Or, the limit type field 150 may take on a third value when the destination limit is driving time, in minutes.

15

The query message 120 concludes with an ending field 152. The ending field 152 preferably includes the newline character, represented in FIG. 3 as "\n".

Before the ending field 152, the query message 120 may also include additional optional fields which specify additional information or service requests from the mobile unit to the base unit 12. For example, the query message 120 may additionally specify a text message to an operator of the base unit 12, or specify whether the base unit 12 should provide maneuver arms information or combined maneuver arms information along with route guidance text. The query message 120 can also specify, for example, whether the base unit 12 should send route stripmap information for a specified strip width with the returned route text, whether the base unit 12 should send responses in a language independent manner, and/or whether map information should be sent by the base unit 12 in bitmap or vector form.

Maneuver arms information is used to represent intersections along the route determined by the base unit 12. Combined maneuver arms information can be provided when two intersections are sufficiently close together. Further, the query message 120 can additionally specify routing options such as route calculations which avoid tolls, avoid left turns or avoid limited access roads, or specify a time of day for the start of the route. Still further, the message 120 could optionally request additional information from the base unit 12, such as a list of point of interest types, a list of points of interest matching search criteria or a list of files which may be communicated from the base unit 12 to the mobile unit to provide descriptive information.

Referring now to FIG. 4, FIG. 4 illustrates a data communications protocol for communicating data from a base unit to a mobile unit in accordance with the invention and which can be used in conjunction with the system of FIG. 1 and the method of FIG. 2. In FIG. 4, a response message 160 is illustrated as including a plurality of fields 162.

In accordance with the invention, the response message 160 may be transmitted in a continuous stream of data, called the burst mode, or in a plurality of discrete responses to queries for data, called the normal mode. The mode of data transmission can be specified by the mobile unit, for example, in an additional field included in the query message 120. In the burst mode, the base unit 12 transmits data as fast as possible, without waiting for requests from the mobile unit. In the normal mode, the base unit 12 sends a packet, then waits for the mobile unit to request the next packet before sending the next packet.

As mentioned above, the response transmitted from the base unit 12 to a mobile unit may include maneuver arms information. Maneuver arms are graphical vectors used by the mobile unit for displaying a graphical representation of an intersection to be traversed. At least three types of visual information can be transmitted by the base unit. These include a geometric representation of the intersection, including arms representing the streets approaching an intersection and the angles at which the streets approach the intersection. The transmitted information can further include which of the streets is included in the route to be travelled so that, for example, that street may be highlighted in the graphical display. The transmitted information can further include information about street signs located at the intersection.

In one embodiment, the maneuver arms information includes only sufficient data to create a display showing only what the driver of a vehicle containing the mobile unit will see as the driver traverses the displayed intersection. Other, extraneous information, such as a map of the region around the intersection or of the entire metropolitan region, is not transmitted.

16

Transmitting only a representation of intersections to be traversed, rather than extraneous information, greatly reduces data transmission and storage requirements. Thus, a relatively low bandwidth channel may be used for transmitting queries and responses between the base unit 12 and the mobile unit. For example, a channel having a bandwidth as low as 1,200 bits per second may be used. In contrast, transmitting extraneous information may require a bandwidth as high as 1 megabit per second. Since, with the invention, the amount of data transmitted is relatively small, the entire response, including maneuver arms information, may be transmitted in a reasonable time, even at a low bandwidth. In addition, since only pertinent information about intersections is transmitted, only a small amount of memory, such as memory 26 of the desktop personal computer 16 (FIG. 1) is required at the mobile unit.

After an intersection has been traversed, the display is, in general, updated to show the next intersection to be traversed, using maneuver arms information received from the base unit and stored in memory. The display can be updated in response to operator control, for example, by operating a switch or by voice control, or automatically in response to a position sensor such as the position locator 42 of the laptop personal computer 18 (FIG. 1).

The response message 160 preferably includes a message length field 164 which specifies the length of the response message 160. In addition, the message length field 164 may include a compression marker character 165. The compression marker character 165 may take on one of a number of values. For example, the compression marker character 165 may take on a first value if the response message 160 is compressed using the current phrase compression table. The compression marker character 165 may take on a second value if the response message 160 is compressed using the current dictionary (bit compression) table. The compression marker character 165 may take on a third value if the response message 160 is compressed according to the L-Z (Lev-Zempel) compression algorithm. The compression marker character 165 may take on a fourth value or simply not be present if the response message 160 is not compressed in any way.

The response message 160 further includes a CRC field 166 which is preferably the computed CRC-16 of the message 160, starting with the delimiter following the CRC field 166 up to and including the ending character of the message 160. The response message 160 further includes a time stamp field 168 which specifies the number of seconds since the epoch (00:00:00 GMT Jan. 1, 1970) when this message was sent. Preferably, messages older than 20 minutes will be ignored by the mobile unit which receives the message.

The response message 160 further includes a subscriber identifier field 170. This field preferably specifies information used for auditing, billing and authorization.

The response message 160 further includes a message identification field 172. In accordance with the invention, the contents of the message identification field 170 of the response message 160 match the contents of the message ID field 132 of the query message 120.

The response message 160 further includes an identifier field 174. Preferably, the contents of the identifier field 174 of the response message 160 match the contents of the identifier field 134 of the query message 120.

The response message 160 also includes a type field 176 and a message field 178. The type field 176 specifies the type of the message contained in the message field 178. For example, the type field 176 may have a first value (for

example type "R") specifying that the message field 178 contains route tracking address translation information. Such a message would result: from the base unit 12 having received a route tracking query. The message in the message field 178 is then the address corresponding to the current position (latitude, longitude). The type field 176 may have a second value specifying that the message field 178 includes route guidance information. This message would result from the base unit 12 having received a route calculation request.

The message is the set of driving instructions. The instructions will contain several lines of text, each separated by carriage return/newline characters. There may be several messages of this type communicated for a single route. Each message will correspond to a single maneuver if arms are requested, or be the complete text if arms are not requested.

The message type field 176 may take on a third value to indicate that the message field 178 contains a download of information. This message would result from a query requesting particular information from the base unit 12. The type field 176 may take on a fourth value to indicate that the message field 178 contains an error message. For example, the latitude and longitude specified by the latitude field 136 and the longitude field 138 in the query message may be outside the specified metropolitan region, or the specified address may be invalid or not found for a route calculation. The message field 178 contains the error text defining the error.

The type field 176 may take on a fifth value to specify that the message field 178 contains a query response. Such a message would be the result of a query made of the database, for example requesting a list of point of interest types. The message field 178 includes the query data.

The response message 160 concludes with an ending field 180. Preferably, the ending field 180 includes the newline character, illustrated in FIG. 4 as "\n".

The use of maneuver arms will now be described in greater detail. Maneuver arms are used to depict roads at intersections. If maneuver arms information is requested by a remote unit, the base unit 12 generates the maneuver arms information in a maneuver arm generation module and provides this arms information for a current maneuver to the remote unit. The remote unit, for example computer 18, processes this information and displays the information on a display, for example display 46. The base unit 12 provides the information to the remote unit in the following form:

FromName; ToName; $x_1, y_1; x_2, y_2 [\dots ; x_n, y_n]$

"FromName" is the road being driven on at the beginning of the maneuver. "ToName" is the road being driven on at the end of the maneuver (except for the first maneuver). The x, y values specify the endpoints of the arms from an origin, which is set at the intersection. Each arm starts at the origin and radiates outward to an endpoint x, y . In one preferred embodiment, x and y are integer values between -100 and +100. The base unit 12 scales and rotates the arms so that the from road is vertical on the display and approaches the intersection from the bottom. If there are any arms, in general there will be at least two: a first arm to represent the "from" road using x_1 and y_1 , and a second arm to represent the "to" road using x_2 and y_2 . Other arms specified by x_n and y_n are used to represent any additional roads at the intersection. The signs of the x and y coordinates are shown in FIG. 5.

In one embodiment, the endpoint coordinates of the first, or from, arm are 1, 99 so that the first arm appears to be going straight up from the bottom of the display to the origin. The other arms are mapped relative to the position of this first arm. In this embodiment, endpoint coordinates of

99, -1 correspond to an approximately 90° right turn from the first arm. Endpoint coordinates of -99, 0 correspond to an approximately 90° left turn from the first arm. Endpoint coordinates of 1, -100 correspond to proceeding straight: ahead through the intersection.

For the first maneuver, the ToName can represent a cross street near the beginning of a route to orient the driver even though this cross street is not to be turned onto.

FIGS. 6 to 10 illustrate examples of displays in a remote unit in the course of a trip from 1550 Rockwood St., Los Angeles, to 280 Emerald St., Los Angeles. In this example, after the driver enters the from information "1550 ROCKWOOD ST, LOS ANGELES" and the to information "1280 EMERALD ST, LOS ANGELES" the display in the remote unit informs the driver of the approximate driving distance and driving time by displaying "ABOUT 0.4 MILES, 3 MINUTES" (not shown in FIGS. 6 to 10). Then, as the driver proceeds, the display displays the textual and graphic information shown in FIGS. 6 to 10. The directions in textual form are displayed on the left, and corresponding maneuver arms are graphically displayed on the right based on the x, y endpoint coordinates received from the base unit 12. The exact appearance of the display, for example, road width and road edge color, can be customized by the remote user.

FIGS. 11 to 14 illustrate the data transferred between the remote unit and the base unit in the example of FIGS. 6 to 10. More specifically, FIG. 11 illustrates the packet transmitted from the remote unit to the base unit. FIG. 12 illustrates the packet issued from the base unit in response. FIG. 13 illustrates a second communication from the remote unit to the base unit. And, FIG. 14 illustrates a corresponding response from the base unit. In the example of FIGS. 11 to 14, not all of the fields shown in FIGS. 3 and 4 are needed and are thus omitted.

As shown by the "ARMS=Y" designation in an optional routing alternatives field, the request in FIG. 11 includes a request for maneuver arms information. In the second message in FIG. 12, the base unit begins to send maneuver arms information, in the format described above, via the "ARM=ROCKWOOD,GLENDALE;1,99;-91,41;90,-42" instruction. The optional "MORE=Y" instruction in the fifth message of FIG. 12 indicates that there are more packets of messages to follow. The "MANEUVER=NEXT" and "ARMS=Y" instructions of FIG. 13 direct the base unit 12 to send the additional information, including maneuver arms information. This additional information is sent via the packet shown in FIG. 14.

FIGS. 15 to 38 illustrate additional examples of data transferred between a remote unit and a base unit. FIG. 15 illustrates a packet sent by a remote unit to a base unit which constitutes the initial log-in communication that sets a non-burst mode and a 1K maximum packet size. FIG. 16 illustrates the response to the request of FIG. 15. FIG. 16 is a response which merely acknowledges the request of FIG. 15 because there is insufficient information for a route request or a query.

FIG. 17 illustrates a request to use a Los Angeles, Calif. database for future requests and FIG. 18 illustrates the corresponding acknowledgement.

FIG. 19 illustrates a request for a route from 950 S. Flint Ridge Way to 2043 N. Sacramento along with maneuver arms. FIG. 20 illustrates a first packet in response to the request of FIG. 19. FIG. 21 illustrates a request from the remote unit to the base unit to send the next packet of instructions along with maneuver arms.

FIG. 22 illustrates a response providing the next packet, as requested. FIG. 23 illustrates a request for the next block

of instructions and FIG. 24 illustrates the next block of instructions. Finally, FIG. 25 illustrates a request for the last block of instructions and FIG. 26 illustrates the corresponding response.

Thus, FIGS. 19 to 26 together illustrate the communications to provide the route from 950 S. Flint Ridge Way to 2043 N. Sacramento.

FIG. 27 illustrates a request for a route from 1750 Queens Road to 7530 Orangethorpe, along with maneuver arms. FIG. 28 illustrates the packet giving the first block of instructions in response to the FIG. 27 request.

FIG. 29 requests the next block of maneuvers. And, FIG. 30 illustrates the final block of maneuvers.

FIG. 31 illustrates a request for a list of all points of interest (POIS) of the restaurant type with "HAPPY" in their name within 10.0 miles (encoded as "100" and "M") of 1855 W. Katella Avenue. FIG. 32 illustrates the response indicating that there are no such points of interest found which satisfy the given criteria. FIG. 33 illustrates another request for a list of points of interest of the restaurant type with "HUNGRY" in their name within 10.0 miles of 1855 W. Katella Avenue. FIG. 34 illustrates the corresponding response providing the information for two points of interest satisfying the criteria set forth in the message of FIG. 33. In FIG. 34, "HUNGRY TIGER SEAFOOD RESTAURANT" at "6231 MANCHESTER BLVD, BUENA PARK" is the first point of interest. The "36" is the type of point of interest, i.e., restaurant.

The "23606" is a unique identification number for the point of interest. The "0-0-223-137,4,1" specifies the restaurant location relative to a known node in the metropolitan region. The "46646" is the distance to the restaurant in feet and the "N" indicates that no additional information regarding the restaurant is available.

FIG. 35 is a packet sent from a remote unit to a base unit which requests a list of points of interest of the restaurant type with "BURGER" in their name within 10.0 miles of 1855 W. Katella Avenue. FIG. 36 illustrates the first packet in response to the request of FIG. 35. FIG. 37 requests additional points of interest in response to the request of FIG. 35. FIG. 38 provides additional points of interest satisfying the criteria in the request in FIG. 35.

The invention generates combined maneuver arms in situations where turns are required at two different intersections which are close together. FIG. 39 illustrates an example of a combined maneuver arm. In the example of FIG. 39, a slight right turn is required at the corner of Broad Street and Elm Street and a left turn is required at the intersection of Elm Street and Main Street. Instead of generating maneuver arms for the Broad-to-Elm turn and another set of maneuver arms for the Elm-to-Main turn, the invention generates a single combined maneuver arms display, as shown in FIG. 39, by the following process.

For each set of maneuver arms generated at an intersection, the base unit 12 determines whether there is a sufficiently close intersection at which the driver must turn. If sufficiently close intersections requiring turns occur, then the maneuver arms information for both of these intersections are merged for a single combined maneuver arms display such as that shown in FIG. 39. For the combined maneuver arms, the roads are designated by sets of endpoints, similar to that described above in connection with FIG. 5. One acceptable form for combined maneuver arms is as follows:

FromName, ToName, $ox_a, oy_a, x_{a1}, y_{a1}; x_{a2}, y_{a2}; x_{an}, y_{an};$

ToName, $ox_b, oy_b, x_{b1}, y_{b1}; x_{b2}, y_{b2}; x_{bn}, y_{bn}$

The ox_a and oy_a coordinates specify the coordinates of the first, or a^{th} , intersection, or origin, and the ox_b and oy_b

coordinates specify the coordinates of the second, or b^{th} , intersection, or "origin." The arms are specified with respect to these origins. For example, x_{a1} and y_{a1} are the endpoint coordinates of the 1st road at the first, or a^{th} , intersection. To conserve space, coordinates for "origins" other than the first can be omitted because they can be reconstructed from the from/to arm data.

Combined textual information is also displayed along with combined maneuver arms. Thus, along with the graphic display shown in FIG. 39, the following textual instructions are also displayed: "Turn slight right on ELM ST. followed shortly by a left turn onto MAIN ST. Drive 5.6 miles." Three or more intersections can be combined.

An additional feature of the invention is the transmission of message information, that is, the information in message field 178 in FIG. 4, in a further compressed form. The use of such a form has at least two advantages. First, use of such a form allows message information to be transmitted electromagnetically in a more efficient way. Second, use of such a form allow transmission of information from the base unit 12 to a remote unit in a language independent manner. Upon receipt of the information in this form, the remote unit then converts the information for display into expanded textual instructions in any desired language such as English, Spanish, Japanese, and/or German. This form will generally be referred to herein as the language independent form or language independent mode.

In the language independent mode, the textual description of maneuvers are generated by a token generation module in base unit 12 and are transmitted to the remote unit in a tokenized form. For example, instructions to:

Turn left on W. MAIN ST. and drive 4.3 miles.

Would be transmitted as:

3,W.MAIN ST.,4.3.

In this example, the "3" represents the English instruction to:

Turn left on [blank 1] and drive [blank 2] miles.

The "W. MAIN ST." field is the information to be inserted in the [blank 1] position (corresponding to a street sign) and the "4.3" field is the information to be inserted in the [blank 2] position. If German language instructions are desired, then the remote unit displays the following text for a type "3" instruction:

Auf [blank 1] links abbiegen und [blank 2] Meilen weiterfahren.

Thus, using the 5th message of FIG. 12 as another example, instead of transmitting "Turn LEFT onto EMERALD DR. v Drive 0.1 miles." the following tokenized information is transmitted to convey the same information in a much more compact form:

3,EMERALD DR.,0.1

FIG. 40 provides additional examples of tokens and corresponding expanded text in English, Spanish, and German.

Upon receiving the tokenized route information, the remote unit applies a set of translating instructions contained in a lookup table implemented, example, in computer 18, one table per language, or sounding, desired. For example, the English token translation instructions for a type 3 token indicate that "Turn left on" is displayed, then the signage or street name, then "and drive," then the distance, and then "miles." The remote unit can be equipped with a set of buttons for the user to specify the desired language(s).

Translation instruction can be more or less complicated and can include conditions for added flexibility. For example, the English token translation instructions for a type 5 instruction indicate that "Follow the sign" is displayed

first, then if the number of signs in the message is greater than one an "s" should be added to "sign," then the sign(s) should be displayed, then "on the ramp." should be displayed. Thus, in one instance a type 5 token might produce, expanded English maneuver text of:

Follow the signs TO O'HARE, TO INDIANA on the ramp.

In another instance, a type 5 token might produce the expanded English maneuver text of:

Follow the sign TO CHICAGO on the ramp.

The remote unit can also convert the miles, information into kilometers, if desired.

Thus, in the language independent mode, information is transmitted from the base unit without regard to any particular language. Accordingly, the transmission bandwidth does not depend on the language of the instructions to be displayed on the display in the remote unit. Because the remote unit produces the actual text portion, routes can be presented in more than one language or way either concurrently or serially, as desired by the remote user, without the need for additional information from the base unit.

Use of tokens allows remote system users to create their own language formats, if desired, to best fit particular needs and capabilities. Alternatively, a remote unit can download language formats (that is, expanded text corresponding to various tokens) that have already been created from the base unit.

The base unit can also provide the remote units with other information in addition to the textual directions and maneuver arms information discussed above. In some applications, a remote user desires more information than just the textual directions and maneuver arms information and more information than is stored and maintained in the remote unit. For various practical reasons, such as cost, remote units generally have at best only a limited database on-board. Such a limited database may, for example, include information and/or maps for a limited metropolitan area.

Even though a remote user may have no or a limited on-board database, the invention allows the remote user to obtain a large amount of information from the base unit. Thus, the invention allows a remote unit to access a large amount of information without burdening the remote unit with storage and maintenance of a large database. Such information can include, for example, maps for a complete route (not just information about intersections which require turns) or maps for an area which is simply not covered by any on-board database.

FIG. 41 is a flowchart which illustrates the operations in a remote unit, such as computer 18, for determining whether the remote unit needs additional information from the base unit and for obtaining such additional information when it is needed. In the operations illustrated in FIG. 41, the remote unit has at small on-board database.

In step S1, the remote unit requests a route between an origin and a destination from the base unit using the protocol shown in FIGS. 3 and 11. The base unit 12 calculates the route in route calculator 66 and this route is received in the remote unit in step S2. In step S3, the remote unit compares the route received from the base unit with map information stored on-board the remote unit. In a preferred embodiment, the comparison is made on a node basis. If any part of the route is not adequately covered by on-board maps in terms of geographic scope/bound or level of detail/content, as determined at step S4, then the processing proceeds on to step S5. Otherwise, the processing proceeds on to step S7 and is completed.

In step S5, the remote unit requests, from the base unit 12, stripmaps for those portions of the route which are not

adequately covered by maps available on-board the remote unit. Maps are not requested for areas which are adequately covered by on-board maps. A stripmap can be relatively simple or it can be fairly detailed and include side roads, intersections, points of interest, and features for map-matching in the remote unit. In step S6, the remote unit receives the requested strip-map information from the base unit.

A similar procedure is used when a route is within the area covered by the on-board database but the base unit has more up-to-date information. The remote unit can also download updated maps, new programs, and the like. Remote units without any on-board database must obtain all information from the base unit. A remote unit specifies what information it needs, using the above-described protocol, based on what information the remote unit desires and can handle.

Included herewith as Microfiche Appendix A is a copy of computer code for implementing the packet/message interpretation and parsing functions described above.

As can be seen from the foregoing, the invention provides a system and method for providing graphically referenced information from a base unit or server to a mobile unit in a compact form. The invention allows the mobile unit to operate with limited or no database storage or position sensor requirements. Software for controlling the mobile unit runs on generic hand-held devices or desktop computers with wireless or wireline communications capability. A query, communicated from the mobile unit to the base unit, and the response, communicated from the base unit to the mobile unit, are packaged into a standard data communications protocol that manages a broad spectrum of queries and responses available. This approach to providing route guidance information allows automatic real time database updates and corrections at the base unit, avoiding database distribution problems. In addition, the cost and technical requirements for the on-board or mobile unit equipment are substantially lower than for prior art route guidance information systems.

It is to be understood that, while the detailed drawings and specific examples given describe preferred embodiments of the invention, they are for the purpose of illustration only. The invention is not limited to the precise details disclosed, and various changes may be made therein. For example, the format or protocol of the query message and the response message, illustrated in FIGS. 3 and 4, respectively, may be modified to request different types of information from the map database or to specify different formats or subsets of information to be conveyed to the mobile unit. Such changes may be made without departing from the spirit of the invention which is defined by the following claims.

What is claimed is:

1. A method of expanding the amount of information available to a remote unit in a routing system having a base unit and a remote unit, comprising the steps of:

- (a) electromagnetically transmitting a route request from the remote unit to the base unit;
- (b) electromagnetically transmitting data representing a route from the base unit to the remote unit in response to the route request of step (a);
- (c) receiving in the remote unit the data representing a route transmitted in step (b);
- (d) in the remote unit, using a navigation application program to compare the data representing a route received in step (c) with coverage of databases on-board the remote unit;
- (e) if an entire route received in step (c) is not covered by said databases on-board the remote unit, electromag-

23

netically transmitting from the remote unit to the base unit a request for the base unit to provide information in addition to that which is covered by said databases on-board the remote unit; and

(f) receiving in the remote unit said information in response to the request of step (e).

2. The method as set forth in claim 1, wherein step (f) includes receiving in the remote unit map information which is not adequately covered by said databases on-board the remote unit in response to the request of step (e).

3. A routing system which makes a large amount of information available to a remote unit, the system comprising:

(a) a base unit;

(b) a remote unit including a navigation application program installed therein; and

(c) a communications link to electromagnetically transmit a route request from the remote unit to the base unit and to electromagnetically transmit data representing a route from the base unit to the remote unit in response to the route request;

wherein the remote unit

(i) receives the data representing a route transmitted by the communications link,

(ii) compares the data representing a route received with coverage of databases on-board the remote unit,

(iii) uses said navigation application program to determine what additional data is needed, and

(iv) electromagnetically transmits from the remote unit to the base unit, via the communications link, an additional request for the base unit to provide said additional information.

4. The routing system as set forth in claim 3, wherein the remote unit receives map information which is not adequately covered by said databases on-board the remote unit in response to said additional request.

5. A system for providing navigation features to remote mobile navigation units comprising:

a plurality of remote navigation units each of which is installed in a respective one of a plurality of vehicles, wherein each of said plurality of remote navigation units is comprised of:

a position indicator that provides an output indicative of a geographical position thereof;

an input device that provides for receiving a request for a navigation function from a user;

a first processor coupled to receive outputs from said position indicator and said input device, and further wherein said first processor executes a first navigation application program to provide the requested navigation function to the user of the remote navigation unit;

a first geographic database installed in said remote unit and used in conjunction with the first navigation application program executed on the first processor of the remote navigation unit;

wherein said first navigation application program determines what additional data beyond what is included in said first geographic database is required to provide said requested navigation function to the user; and

a first wireless communications system coupled to said first processor to provide for sending requests for said additional data and receiving responses to said requests; and

24

a base unit comprised of:

a second wireless communications system that provides for receiving said requests for said additional data from each of said plurality of remote navigation units and sending responses thereto;

a second geographic database; and

a second processor coupled to said second wireless communications system and said second geographic database, wherein said second processor executes a second navigation application program that prepares responses to said requests from the plurality of remote navigation units using said second geographic database and sends said responses to said plurality of remote navigation units using said second wireless communication system; and

wherein said first navigation application program provides said requested navigation function to the user using data from said first geographic database and said additional data from said second geographic database.

6. The invention of claim 5 wherein said navigation function requested by the user includes calculation of a route between an origin and a destination.

7. The invention of claim 5 wherein said navigation function requested by the user includes display of map data.

8. The invention of claim 5 wherein said navigation function requested by the user includes display of strip maps.

9. The invention of claim 5 wherein said navigation function requested by the user includes a request for more up-to-date information.

10. The invention of claim 5 wherein said input device provides for selection of a destination.

11. A method of providing navigation information to a plurality of users of remote navigation units comprising the steps of:

on each of said plurality of remote navigation units, receiving a request for navigation information from a user;

executing a first navigation application program that uses a first geographic database installed in said remote navigation unit to provide a first part of a response to said request for navigation information and determine whether additional data are to be requested from a base unit;

using a wireless communication system to communicate a request to said base unit navigation system to obtain said additional data related to said request for navigation information as determined by said navigation application program;

receiving said additional data related to said request from said base unit navigation system;

combining said first part of a response with said additional information to provide a combined response; and providing said combined response to said user.

12. The invention of claim 11 wherein said step of using a wireless communication system to communicate a request further comprises:

requesting a route between an origin and a destination.

13. The invention of claim 11 wherein said step of using a wireless communication system to communicate a request further comprises:

requesting map data for areas that are not adequately covered by said first geographic database.

25

14. The invention of claim 11 wherein said step of using a wireless communication system to communicate a request farther comprises:

requesting strip maps.

15. The invention of claim 11 wherein said step of using a wireless communication system to communicate a request further comprises:

requesting more up-to-date information than is contained in said first database.

16. A method for providing improved navigation services to a plurality of remote navigation units comprising the steps of:

on a remote unit comprising a first navigation system that includes a first geographic database and a navigation application program, receiving input from a user for a desired navigation function to which a response requires geographic data;

from the remote unit, using said navigation application program to transmit a request for part of said geographic data not in said database determined by said program as required to provide said desired navigation function;

26

on a base unit comprising a second navigation system that uses a second geographic database, receiving said request and providing said part of said geographic data using said second geographic database;

from said base unit, transmitting said part of said geographic data to said remote unit; and

in said remote unit, receiving said part of said geographic data from said base unit and using said part of said geographic data received from said base unit along with data from said first geographic database to provide said desired navigation function to said user.

17. The method of claim 16 wherein said desired navigation function comprises calculation of a route between an origin and a destination, wherein said request for part of said geographic data comprises a calculated route, and wherein said step of using includes map display.

18. The method of claim 16 further comprising the step of: on said remote unit, after receiving said part of said geographic data, comparing said part with data in said first database and then requesting additional data from said base unit.

* * * * *

AF/2173

10/B

7-29-01
B. Hilliard



IN THE UNITED STATES PATENT AND TRADEMARK OFFICE

Applicant : McNally et al. Group Art Unit: 2173
 Serial No. : 09/400,413 Examiner : Cao Nguyen
 Filed : September 21, 1999
 For : INFORMATION MANAGEMENT AND SYNCHRONOUS
 COMMUNICATIONS SYSTEM WITH MENU GENERATION

AMENDMENT

RECEIVED
JUL 26 2001
Technology Center 2100

Commissioner for Patents
Washington, D.C. 20231
Box AF

Sir:

In response to the Final Rejection dated May 22, 2001, please amend the above-identified application as follows:

IN THE CLAIMS

Please cancel rejected claims 1-19, 31-39, 44-54, 56 and 57 without prejudice.

REMARKS

By the present amendment, rejected claims 1-19, 31-39, 44-54, 56 and 57 have been cancelled. These claims will be pursued in a continuation application.

In light of this amendment, Applicants respectfully request that this application be passed to issue.

AUTHORIZATION

The Commissioner is hereby authorized to charge any additional fees which may be required for this amendment, or credit any overpayment to Deposit Account No. 13-4500, Order No. 3125-4002US1. **A DUPLICATE OF THIS DOCUMENT IS ATTACHED.**

In the event that an extension of time is required in addition to that requested in a petition for an extension of time, the Commissioner is requested to grant a petition for that extension of time which is required to make this response timely and is hereby authorized to charge any fee for such an extension of time or credit any overpayment for an extension of time to Deposit Account No. 13-4500, Order No. 3125-4002US1. **A DUPLICATE OF THIS DOCUMENT IS ATTACHED.**

Respectfully submitted,
Morgan & Finnegan, L.L.P.

Date: July 19, 2001

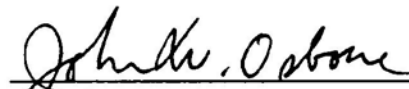

By: John W. Osborne
Registration No. 36,231

Mailing Address:
MORGAN & FINNEGAN, L.L.P.
345 Park Avenue
New York, NY 10154-0053
TELEPHONE: 212-758-4800
TELECOPIER: 212-751-6849



PATENT

Docket No. 3125-4002US1

IN THE UNITED STATES PATENT AND TRADEMARK OFFICE

RECEIVED
JUL 26 2001
Technology Center 2100

Applicant(s) : McNally et al.
Serial No. : 09/400,413 Group Art Unit: 2173
Filed : September 21, 1999 Examiner: Cao Nguyen
For : INFORMATION MANAGEMENT AND SYNCHRONOUS
COMMUNICATIONS SYSTEM WITH MENU GENERATION

CERTIFICATE OF MAILING (37 C.F.R. 1.8a)

Commissioner for Patents
Washington, D.C. 20231

Sir:

I hereby certify that the attached:

1. Amendment; and
2. Return Receipt Postcard

along with any paper(s) referred to as being attached or enclosed and this Certificate of Mailing are being deposited with the United States Postal Service on date shown below with sufficient postage as first-class mail in an envelope addressed to the: Commissioner for Patents, Washington, D.C., 20231.

Respectfully submitted,

MORGAN & FINNEGAN, L.L.P.

Angus Gill

Dated: July 19, 2001

CORRESPONDENCE ADDRESS:
MORGAN & FINNEGAN LLP
345 Park Avenue
New York, New York 10154
(212) 758-4800
(212) 751-6849 Facsimile

FORM: CERT..NY
Rev. 05/27/98

636880 v1



**UNITED STATES DEPARTMENT OF COMMERCE
Patent and Trademark Office**

Address: COMMISSIONER OF PATENTS AND TRADEMARKS
Washington, D.C. 20231

APPLICATION NO.	FILING DATE	FIRST NAMED INVENTOR	ATTORNEY DOCKET NO.
-----------------	-------------	----------------------	---------------------

JOHN W. OSBORNE
MORGAN & FINNEGAN, LLP
345 PARK AVENUE
NEW YORK, NY 10154

EXAMINER

ART UNIT	PAPER NUMBER
----------	--------------

DATE MAILED: 08/09/01

Please find below and/or attached an Office communication concerning this application or proceeding.

Commissioner of Patents and Trademarks

Notice of Allowability

Application No. 09/400,413	Applicant(s) McNally et al.
Examiner Cao "Kevin" Nguyen	Art Unit 2173

--The MAILING DATE of this communication appears on the cover sheet with the correspondence address--

All claims being allowable, PROSECUTION ON THE MERITS IS (OR REMAINS) CLOSED in this application. If not included herewith (or previously mailed), a Notice of Allowance and Issue Fee Due or other appropriate communication will be mailed in due course. **THIS NOTICE OF ALLOWABILITY IS NOT A GRANT OF PATENT RIGHTS.** This application is subject to withdrawal from issue at the initiative of the Office or upon petition by the applicant. See 37 CFR 1.313 and MPEP 1308.

- 1. This communication is responsive to 07/23/01
- 2. The allowed claim(s) is/are 20-30, 40-43, and 55
- 3. The drawings filed on _____ are acceptable as formal drawings.
- 4. Acknowledgement is made of a claim for foreign priority under 35 U.S.C. § 119(a)-(d).
 - a) All b) Some* c) None of the:
 - 1. Certified copies of the priority documents have been received.
 - 2. Certified copies of the priority documents have been received in Application No. _____
 - 3. Copies of the certified copies of the priority documents have been received in this national stage application from the International Bureau (PCT Rule 17.2(a)).
- *Certified copies not received. _____
- 5. Acknowledgement is made of a claim for domestic priority under 35 U.S.C. § 119(e).

Applicant has THREE MONTHS FROM THE "MAILING DATE" of this communication to file a reply complying with the requirements noted below. Failure to timely comply will result in ABANDONMENT of this application. **THIS THREE-MONTH PERIOD IS NOT EXTENDABLE FOR SUBMITTING NEW FORMAL DRAWINGS, OR A SUBSTITUTE OATH OR DECLARATION. This three-month period for complying with the REQUIREMENT FOR THE DEPOSIT OF BIOLOGICAL MATERIAL is extendable under 37 CFR 1.136(a).**

- 6. Note the attached EXAMINER'S AMENDMENT or NOTICE OF INFORMAL APPLICATION (PTO-152) which gives reason(s) why the oath or declaration is deficient. A SUBSTITUTE OATH OR DECLARATION IS REQUIRED.
- 7. Applicant MUST submit NEW FORMAL DRAWINGS
 - (a) including changes required by the Notice of Draftsperson's Patent Drawing Review (PTO-948) attached
 - 1) hereto or 2) to Paper No. _____
 - (b) including changes required by the proposed drawing correction filed Mar 2, 2001, which has been approved by the examiner
 - (c) including changes required by the attached Examiner's Amendment/Comment or in the Office action of Paper No. _____

Identifying indicia such as the application number (see 37 CFR 1.84(c)) should be written on the drawings. The drawings should be filed as a separate paper with a transmittal letter addressed to the Official Draftsperson.

- 8. Note the attached Examiner's comment regarding REQUIREMENT FOR THE DEPOSIT OF BIOLOGICAL MATERIAL.
- Any reply to this letter should include, in the upper right hand corner, the APPLICATION NUMBER (SERIES CODE/SERIAL NUMBER). If applicant has received a Notice of Allowance and Issue Fee Due, the ISSUE BATCH NUMBER and DATE of the NOTICE OF ALLOWANCE should also be included.

- Attachment(s)**
- 1 Notice of References Cited (PTO-892)
 - 2 Notice of Informal Patent Application (PTO-152)
 - 3 Notice of Draftsperson's Patent Drawing Review (PTO-948)
 - 4 Interview Summary (PTO-413), Paper No. _____
 - 5 Information Disclosure Statement(s) (PTO-1449), Paper No(s). _____
 - 6 Examiner's Amendment/Comment
 - 7 Examiner's Comment Regarding Requirement for Deposit of Biological Material
 - 8 Examiner's Statement of Reasons for Allowance
 - 9 Other

**CAO "KEVIN" NGUYEN
PATENT EXAMINER
ART UNIT 2173**

ATTACHMENT TO AND MODIFICATION OF
NOTICE OF ALLOWABILITY (PTO-37)

(November, 2000)

NO EXTENSIONS OF TIME ARE PERMITTED TO FILE CORRECTED OR FORMAL DRAWINGS, OR A SUBSTITUTE OATH OR DECLARATION, notwithstanding any indication to the contrary in the attached Notice of Allowability (PTO-37).

If the following language appears on the attached Notice of Allowability, the portion lined through below is of no force and effect and is to be ignored¹:

A SHORTENED STATUTORY PERIOD FOR RESPONSE to comply with the requirements noted below is set to EXPIRE **THREE MONTHS** FROM THE "DATE MAILED" of this Office action. Failure to comply will result in ABANDONMENT of this application. ~~Extensions of time may be obtained under the provisions of 37 CFR 1.136(a)~~

Similar language appearing in any attachments to the Notice of Allowability, such as in an Examiner's Amendment/Comment or in a Notice of Draftperson's Patent Drawing Review, PTO-948, is also to be ignored.

¹ The language which is crossed out is contrary to amended 37 CFR 1.85(c) and 1.136. See "Changes to Implement the Patent Business Goals", 65 Fed. Reg. 54603, 54629, 54641, 54670, 54674 (September 8, 2000), 1238 Off. Gaz. Pat. Office 77, 99, 110, 135, 139 (September 19, 2000)



NOTICE OF ALLOWANCE AND ISSUE FEE DUE

TNBJ 70809

JOHN W. OSBURN
MORGAN & FINNEGAN, LLP
345 PARK AVENUE
NEW YORK, NY 10154

APPLICATION NO.	FILING DATE	TOTAL CLAIMS	EXAMINER AND GROUP ART UNIT	DATE MAILED		
09 100,413	07/21/99	01	HEWITT, J	11/20 09/10/01		
First Named Applicant	MCNALLY, 35 USC 154 (a) (1) (A) (i) 0 Days.					
TITLE OF INVENTION	INFORMATION MANAGEMENT AND SYNCHROGROUP COORDINATION SYSTEM WITH MENU GENERATION					
ATTY'S DOCKET NO.	CLASS-SUBCLASS	BATCH NO.	APPLN. TYPE	SMALL ENTITY	FEE DUE	DATE DUE
2 3105 400	015 810100	001	19 01 01	NO	\$620.00	11/20/01

THE APPLICATION IDENTIFIED ABOVE HAS BEEN EXAMINED AND IS ALLOWED FOR ISSUANCE AS A PATENT. PROSECUTION ON THE MERITS IS CLOSED.

THE ISSUE FEE MUST BE PAID WITHIN THREE MONTHS FROM THE MAILING DATE OF THIS NOTICE OR THIS APPLICATION SHALL BE REGARDED AS ABANDONED. THIS STATUTORY PERIOD CANNOT BE EXTENDED.

HOW TO RESPOND TO THIS NOTICE:

Review the SMALL ENTITY status shown above.
If the SMALL ENTITY is shown as YES, verify your current SMALL ENTITY status:

- A. If the status is changed, pay twice the amount of the FEE DUE shown above and notify the Patent and Trademark Office of the change in status, or
- B. If the status is the same, pay the FEE DUE shown above.

If the SMALL ENTITY is shown as NO:

- A. Pay FEE DUE shown above, or
- B. File verified statement of Small Entity Status before, or with, payment of 1/2 the FEE DUE shown above.

Part B-Issue Fee Transmittal should be completed and returned to the Patent and Trademark Office (PTO) with your ISSUE FEE. Even if the ISSUE FEE has already been paid by charge to deposit account, Part B Issue Fee Transmittal should be completed and returned. If you are charging the ISSUE FEE to your deposit account, section "4b" of Part B-Issue Fee Transmittal should be completed and an extra copy of the form should be submitted.

All communications regarding this application must give application number and batch number.
Please direct all communications prior to issuance to Box ISSUE FEE unless advised to the contrary.

IMPORTANT REMINDER: Utility patents issuing on applications filed on or after Dec. 12, 1980 may require payment of maintenance fees. It is patentee's responsibility to ensure timely payment of maintenance fees when due.

PATENT AND TRADEMARK OFFICE COPY

100-85 (REV. 10-96) Approved for use through 06/30/99. (0651-0033)

App # 09/400413



Issue Batch No. K28
Notice of Allowance Date: 08/09/01
Docket No. : 3125-4002

Patent

IN THE UNITED STATES PATENT AND TRADEMARK OFFICE

Applicant : McNally et al.
Serial No. : ~~08/954,920~~ Group Art Unit : 2173
Filed : September 21, 1999 Examiner : Nguyen, C.
For : INFORMATION MANAGEMENT AND SYNCHRONOUS
COMMUNICATIONS SYSTEM WITH MENU GENERATION

Commissioner for Patents
Washington, D.C. 20231
ATTENTION: OFFICIAL DRAFTSPERSON

SIR:

Submission of Formal Drawings

In response to the Notice of Allowance mailed on August 9, 2001, Applicants submit herewith six sheets of formal drawings (Figs. 1-7).

The sheets included herewith are identical to those included with a Submission of Formal Drawings dated February 26th, 2001. Because of this February 26th submission, Applicants believe that the Examiner unintentionally requested new formal drawings in his Notice of Allowability. Nevertheless, with this Submission Applicants comply with the Examiner's request.

Applicants believe that no fee is due with the submission of these formal drawings. However, in the event that any fees are found to be due, the Commissioner is authorized to charge such fees to Deposit Account No. 13-4500, Order No. 3125-4002. A DUPLICATE COPY OF THIS PAPER IS ATTACHED HERETO.

Respectfully submitted,

MORGAN & FINNEGAN, L.L.P.

Dated: November 1, 2001

By: John W. Osborne
John W. Osborne
Reg. No. 36,231

Mailing Address:
MORGAN & FINNEGAN, L.L.P.
345 Park Avenue
New York, New York 10154-0053
(212) 758-4800 Telephone
(212) 751-6849 Facsimile

150
9200

660982 v1

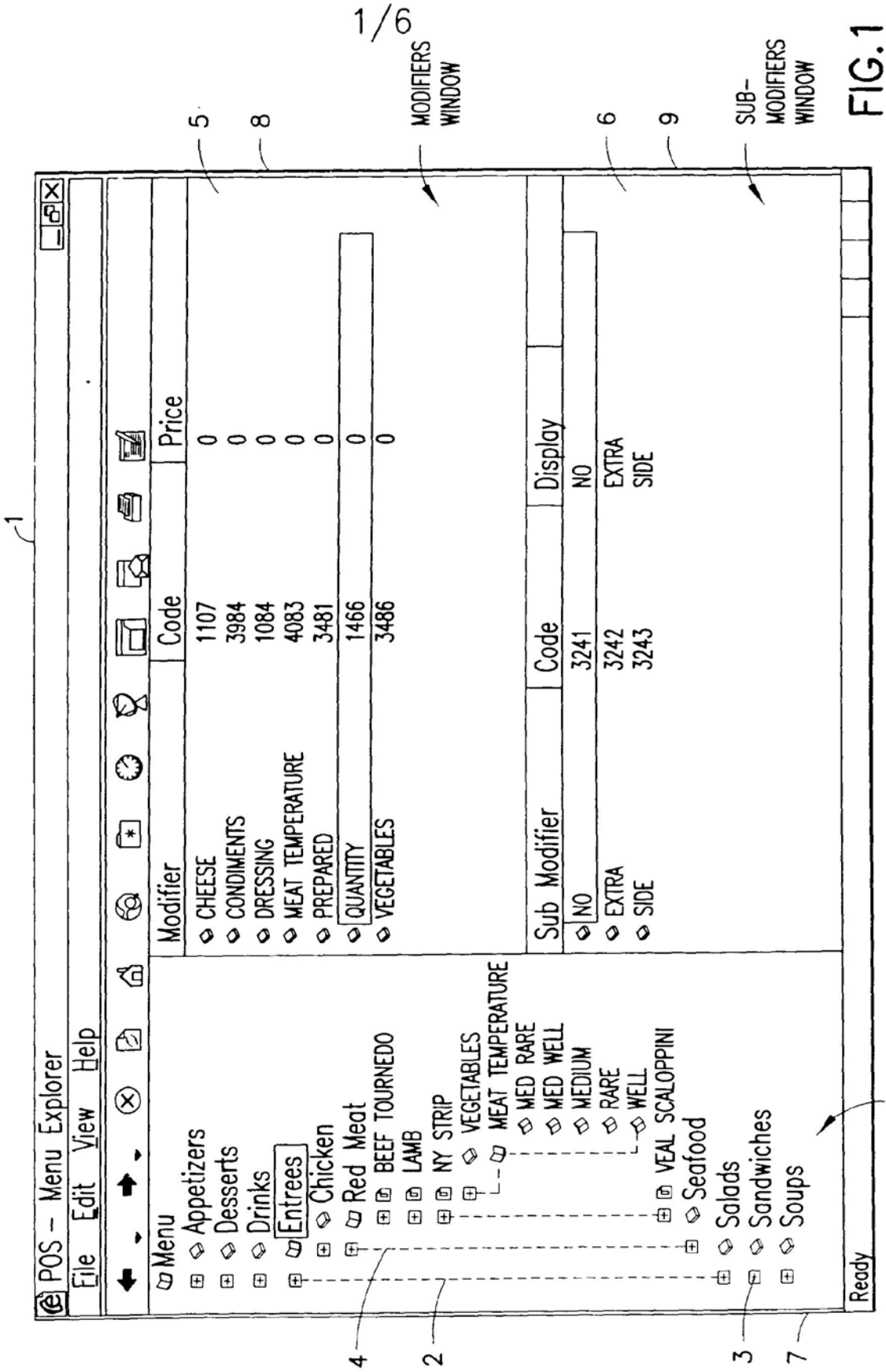

Inventor: McNally et al. Ser. No.: 09/400,413

Date Filed: September 21, 1999

Allowance Date: August 9, 2001

Issue Batch No.: K28 Group Art Unit: 2173

Examiner: C. Nguyen

Title: **INFORMATION MANAGEMENT AND
SYNCHRONOUS COMMUNICATIONS SYSTEM
WITH MENU GENERATION**

Sheet 1 of 6 (Figs. 1-7)



A screenshot of a dialog box titled "Modifier". The dialog box has a close button (X) in the top right corner. It contains four input fields: "Long Name:", "Short Name:", "Code:", and "Price:". The "Price:" field contains the number "0". At the bottom of the dialog box, there are three buttons: "OK", "Cancel", and "Browse". A reference numeral "10" is located to the right of the dialog box.

FIG.2

A screenshot of a dialog box titled "Menu Category". The dialog box has a close button (X) in the top right corner. It contains two input fields: "Long Name:" and "Short Name:". At the bottom of the dialog box, there are three buttons: "OK", "Cancel", and "Browse". A reference numeral "11" is located to the right of the dialog box.

FIG.3

Inventor: McNally et al. Ser. No.: 09/400,413
Date Filed: September 21, 1999
Allowance Date: August 9, 2001
Issue Batch No.: K28 Group Art Unit: 2173
Examiner: C. Nguyen
Title: **INFORMATION MANAGEMENT AND
SYNCHRONOUS COMMUNICATIONS SYSTEM
WITH MENU GENERATION**
Sheet 2 of 6 (Figs. 1-7)



Menu Item

Long Name: Code:

Short Name: Price: Prep. Time:

Recipe

Flame broiled brandy marinated Tender Chicken Breast topped with a creamy cilantro sauce. Served with steamed broccoli, carrots and zucchini.
Spices include lemon pepper, paprika, ginger.

OK Cancel Browse

12

FIG.4

Inventor: McNally et al. **Serial No.:** 09/400,413

Date Filed: September 21, 1999

Allowance Date: August 9, 2001

Issue Batch No.: K28 **Group Art Unit:** 2173

Examiner: C. Nguyen

Title: INFORMATION MANAGEMENT AND
SYNCHRONOUS COMMUNICATIONS SYSTEM
WITH MENU GENERATION

Sheet 3 of 6 (Figs. 1-7)



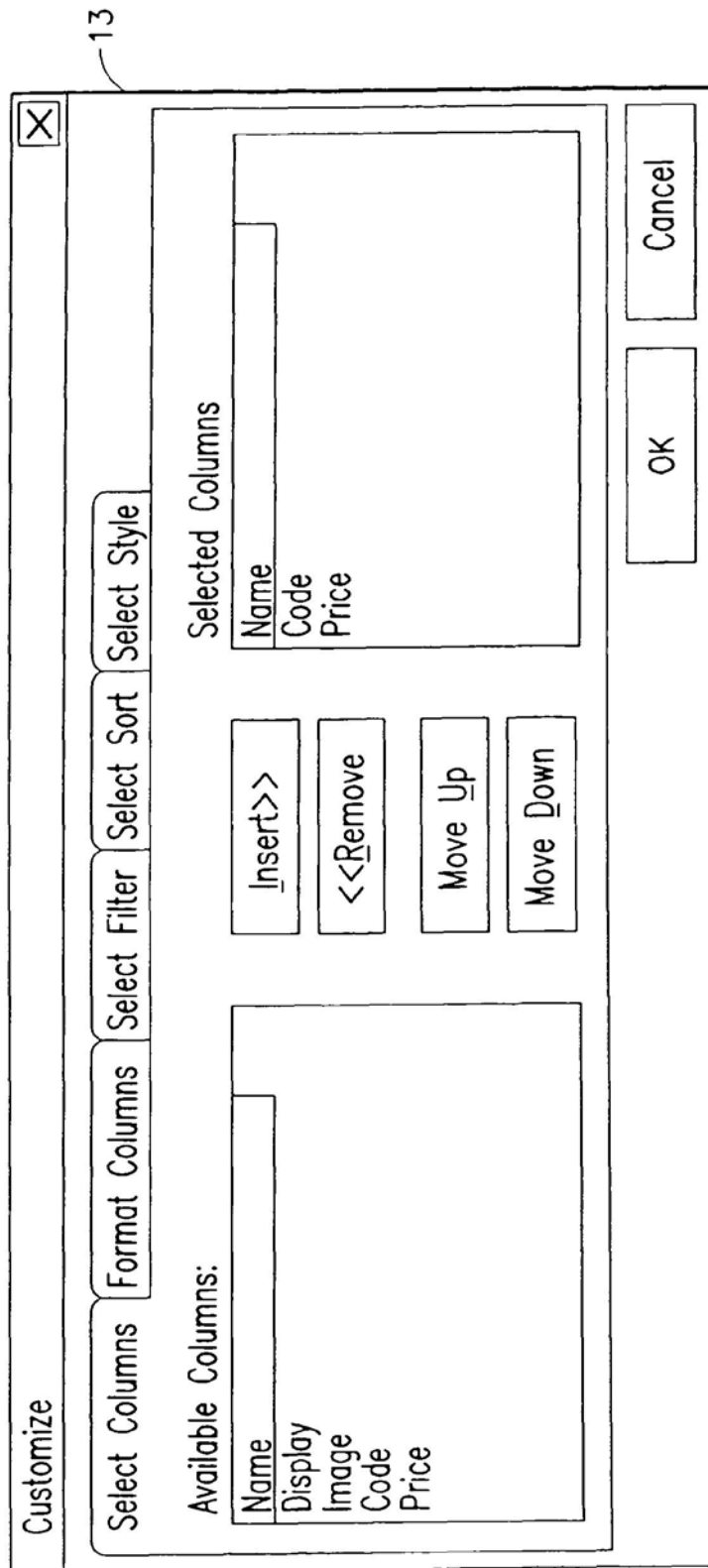

FIG.5

Inventor: McNally et al. Ser. No.: 09/400,413

Date Filed: September 21, 1999

Allowance Date: August 9, 2001

Issue Batch No.: K28 Group Art Unit: 2173

Examiner: C. Nguyen

Title: **INFORMATION MANAGEMENT AND
SYNCHRONOUS COMMUNICATIONS SYSTEM
WITH MENU GENERATION**

Sheet 4 of 6 (Figs. 1-7)



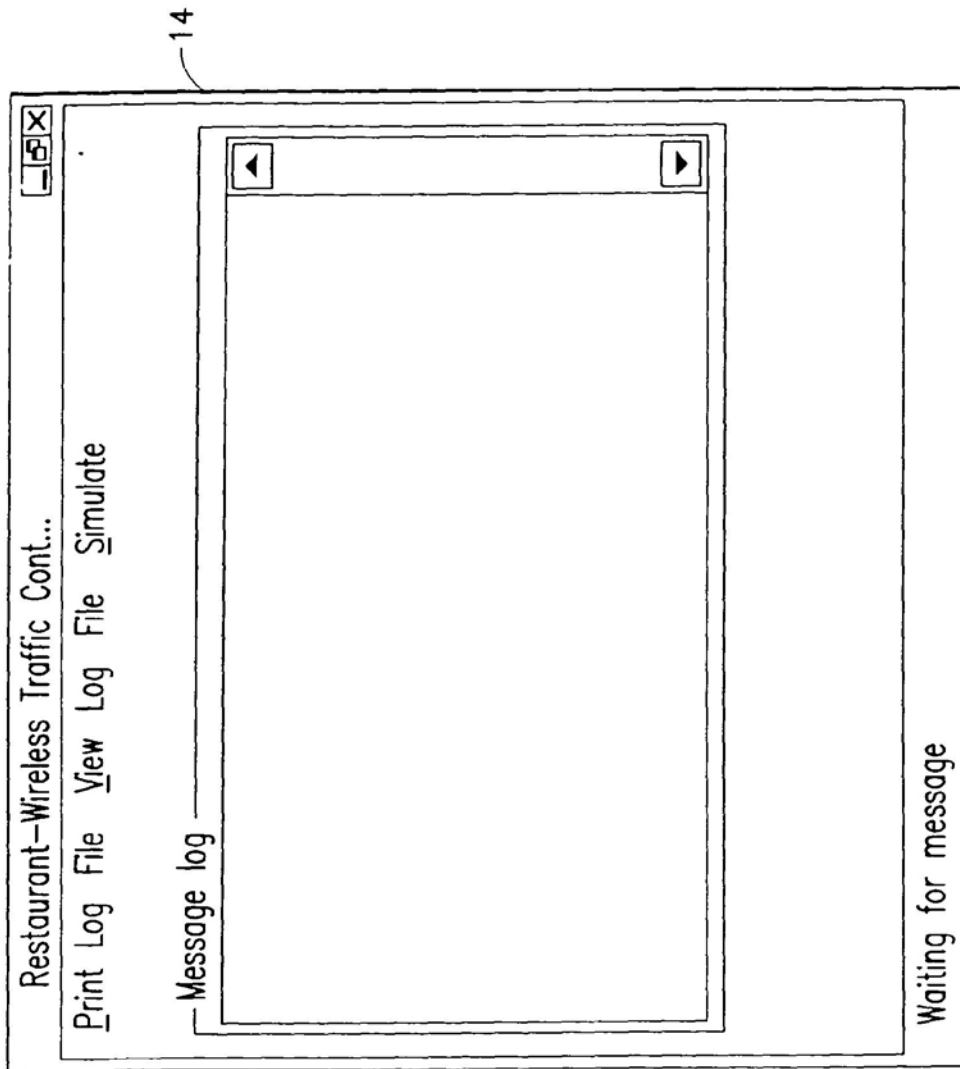

FIG.6

Inventor: McNally et al. **Serial No.:** 09/400,413
Date Filed: September 21, 1999
Allowance Date: August 9, 2001
Issue Batch No.: K28 **Group Art Unit:** 2173
Examiner: C. Nguyen
Title: **INFORMATION MANAGEMENT AND
SYNCHRONOUS COMMUNICATIONS SYSTEM
WITH MENU GENERATION**
Sheet 5 of 6 (Figs. 1-7)



POScE-System

Login CHECKS ORDER VIEW PAY

Choose Item: Tbl67 5st 2

App	Dessert	Drinks	Entrees
Salads	Sdwch	Soups	

Direction:

MAIN PREV PAGE MODS

Select Guest to Order for:

1 2

Last Selection

REMOVE LAST

OK Cancel Browse

15

16

FIG.7

PART B—ISSUE FEE TRANSMITTAL

Complete and mail this form, together with application fees, to:

Box ISSUE FEE
Assistant Commissioner for Patents
Washington, D.C. 20231

bc

JAN 10 2002
3048

MAILING INSTRUCTIONS: This form should be used for transmitting the ISSUE FEE. Blocks 1 through 4 should be completed where appropriate. All further correspondence including the Issue Fee Receipt, the Patent, advance orders and notices of maintenance fees will be mailed to the current correspondence address as indicated unless corrected below or directed otherwise in Block 1, by (a) specifying a new correspondence address; and/or (b) indicating a separate "FEE ADDRESS" for maintenance fee notifications.

Note: The certificate of mailing below can only be used for domestic mailings of the Issue Fee Transmittal. This certificate cannot be used for any other accompanying papers. Each additional paper, such as an assignment or formal drawing, must have its own certificate of mailing.

Certificate of Mailing

I hereby certify that this Issue Fee Transmittal is being deposited with the United States Postal Service with sufficient postage for first class mail in an envelope addressed to the Box Issue Fee address above on the date indicated below.

Angus Gill

(Depositor's name)

[Signature]

(Signature)

1/11/2001

(Date)

JOHN W. OSBORNE
MORGAN & FINNEGAN, LLP
345 PARK AVENUE
NEW YORK NY 10154

TM31/0809

CURRENT CORRESPONDENCE ADDRESS (Note: Legibly mark-up with any corrections or use Block 1)

APPLICATION NO.	FILING DATE	TOTAL CLAIMS	EXAMINER AND GROUP ART UNIT	DATE MAILED
09/400,413	09/21/99	016	NGUYEN, C 2173	08/09/01
First Named Applicant	MCNALLY, 35 USC 154(b) term ext. = 0 Days.			

TITLE OF INVENTION INFORMATION MANAGEMENT AND SYNCHRONOUS COMMUNICATIONS SYSTEM WITH MENU GENERATION

ATTY'S DOCKET NO.	CLASS-SUBCLASS	BATCH NO.	APPLN. TYPE	SMALL ENTITY	FEE DUE	DATE DUE
2 3125-400	345-810.000	K28	UTILITY	YES	\$620.00	11/09/01

1. Change of correspondence address (or indication of "Fee Address" (37 CFR 1.263); Use of PTO form(s) and Customer Number are recommended, but not required.
- Change of correspondence address (or Change of Correspondence Address form PTO/SB/122) attached.
- "Fee Address" indication (or "Fee Address" indication form PTO/SB/47) attached.

2. For printing on the patent front page, list (1) the names of up to 3 registered patent attorneys or agents OR, alternatively, (2) the name of a single firm (having as a member a registered attorney or agent) and the names of up to 2 registered patent attorneys or agents. If no name is listed, no name will be printed.

1 Morgan & Finnegan, LLP
2 _____
3 _____

3. ASSIGNEE NAME AND RESIDENCE DATA TO BE PRINTED ON THE PATENT (print or type)
PLEASE NOTE: Unless an assignee is identified below, no assignee data will appear on the patent. Inclusion of assignee data is only appropriate when an assignment has been previously submitted to the PTO or is being submitted under separate cover. Completion of this form is NOT a substitute for filing an assignment.

(A) NAME OF ASSIGNEE Ameranth Wireless

(B) RESIDENCE: (CITY & STATE OR COUNTRY) San Diego, CA

Please check the appropriate assignee category indicated below (will not be printed on the patent)
 Individual Corporation or other private group entity government

4a. The following fees are enclosed (make check payable to Commissioner of Patents and Trademarks):

- Issue Fee
 Advance Order - # of Copies 10

4b. The following fees or deficiency in these fees should be charged to:

- DEPOSIT ACCOUNT NUMBER 13-4500
(ENCLOSE AN EXTRA COPY OF THIS FORM)
 Issue Fee
 Advance Order - # of Copies _____

The COMMISSIONER OF PATENTS AND TRADEMARKS IS requested to apply the Issue Fee to the application identified above.

(Authorized Signature) *John W. Osborne Reg. No. 36,231* (Date) *Nov. 1, 2001*

NOTE: The Issue Fee will not be accepted from anyone other than the applicant; a registered attorney or agent; or the assignee or other party in interest as shown by the records of the Patent and Trademark Office.

01/15/2002 HTECKLU2 00000147 134500 09400413
01 FC:242 640.00 OP
02 FC:561 20.00 CH 10.00 OP

Burden Hour Statement: This form is estimated to take 0.2 hours to complete. Time will vary depending on the needs of the individual case. Any comments on the amount of time required to complete this form should be sent to the Chief Information Officer, Patent and Trademark Office, Washington, D.C. 20231. DO NOT SEND FEES OR COMPLETED FORMS TO THIS ADDRESS. SEND FEES AND THIS FORM TO: Box Issue Fee, Assistant Commissioner for Patents, Washington D.C. 20231

Under the Paperwork Reduction Act of 1995, no persons are required to respond to a collection of information unless it displays a valid OMB control number.

TRANSMIT THIS FORM WITH FEE

PATENT



✓ BQ be.

3125-4002

IN THE UNITED STATES PATENT AND TRADEMARK OFFICE

Applicant(s) : McNally et al.

Serial No. : 09/400,413 Group Art Unit : 2173

Filed : September 21, 1999 Examiner : Nguyen, C.

For : INFORMATION MANAGEMENT AND SYNCHRONOUS
COMMUNICATIONS SYSTEM WITH MENU GENERATION

Notice of Allowance : August 9, 2001

Issue Batch Number : K28

CERTIFICATE OF MAILING (37 C.F.R. 1.8a)

Commissioner for Patents
Box ISSUE FEE
Washington, D.C. 20231

Sir:

I hereby certify that the following attached papers and fees

1. Issue Fee Transmittal;
2. Check in the amount of \$650.00;
3. Form PTOL-85B;
4. Submission of Formal Drawings;
5. Figs. 1-7 (six sheets); and
6. Postcard.

(along with any paper(s) referred to as being attached or enclosed) and this Certificate of Mailing are being deposited with the United States Postal Service on the date shown below with sufficient postage as first class mail in an envelope addressed to the: Commissioner for Patents, Box ISSUE FEE, Washington, D.C. 20231

Respectfully submitted,

MORGAN & FINNEGAN, L.L.P.

Dated: November 1, 2001

By: 
Angus Gill

Mailing Address:

Morgan & Finnegan, L.L.P.
345 Park Avenue
New York, New York 10154
(212) 758-4800 (Telephone)

660987 v1



US006384850B1

(12) **United States Patent**
McNally et al.

(10) **Patent No.:** **US 6,384,850 B1**
(45) **Date of Patent:** **May 7, 2002**

(54) **INFORMATION MANAGEMENT AND SYNCHRONOUS COMMUNICATIONS SYSTEM WITH MENU GENERATION**

5,802,526 A * 9/1998 Fawcett et al. 707/104
5,912,734 A * 6/1999 Kinebuchi et al. 345/348
5,991,739 A * 11/1999 Cupps et al. 705/26
6,107,944 A * 8/2000 Behr et al. 340/995

(75) Inventors: **Keith R. McNally**, Santa Clarita;
William H. Roof, San Diego; **Richard Bergfeld**, Chatsworth, all of CA (US)

* cited by examiner

(73) Assignee: **Ameranth Wireless**, San Diego, CA (US)

Primary Examiner—Cao H. Nguyen

(74) *Attorney, Agent, or Firm*—Morgan & Finnegan, LLP

(*) Notice: Subject to any disclaimer, the term of this patent is extended or adjusted under 35 U.S.C. 154(b) by 0 days.

(57) **ABSTRACT**

An information management and synchronous communications system and method facilitates database equilibrium and synchronization with wired, wireless and Web-based systems, user-friendly and efficient generation of computerized menus and reservations for restaurants and other applications that utilize equipment with nonstandard graphical formats, display sizes and/or applications for use in remote data entry, information management and communication with host computer, digital input device or remote pager via standard hardwired connection, the internet, a wireless link or the like.

(21) Appl. No.: **09/400,413**

(22) Filed: **Sep. 21, 1999**

(51) **Int. Cl.**⁷ **G06F 3/00**

(52) **U.S. Cl.** **345/810; 345/841**

(58) **Field of Search** **345/334, 335, 345/340, 352, 353, 765, 744, 781, 810, 841; 705/26, 27, 37**

(56) **References Cited**

U.S. PATENT DOCUMENTS

5,724,069 A * 3/1998 Chen 345/156

16 Claims, 6 Drawing Sheets

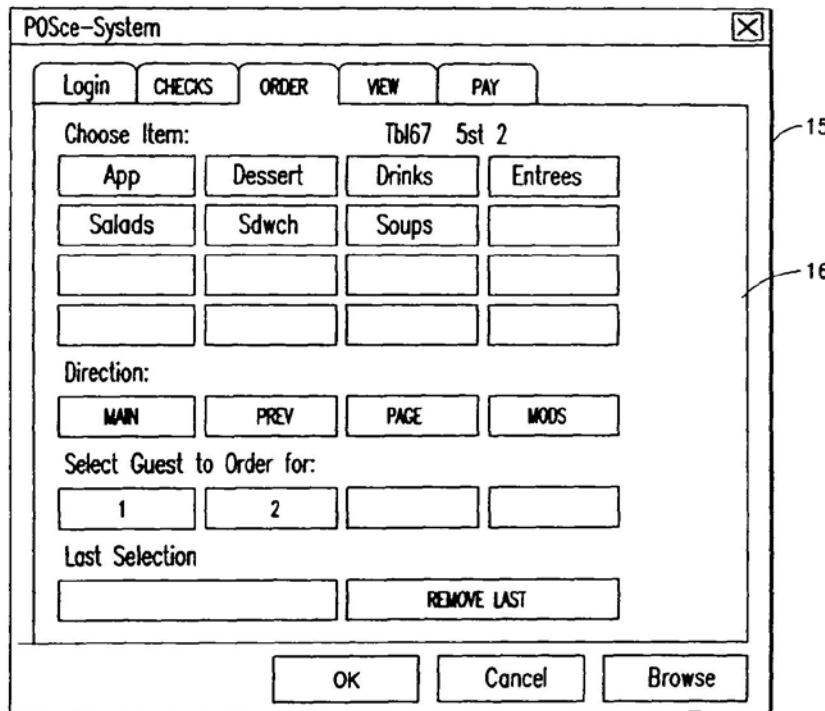

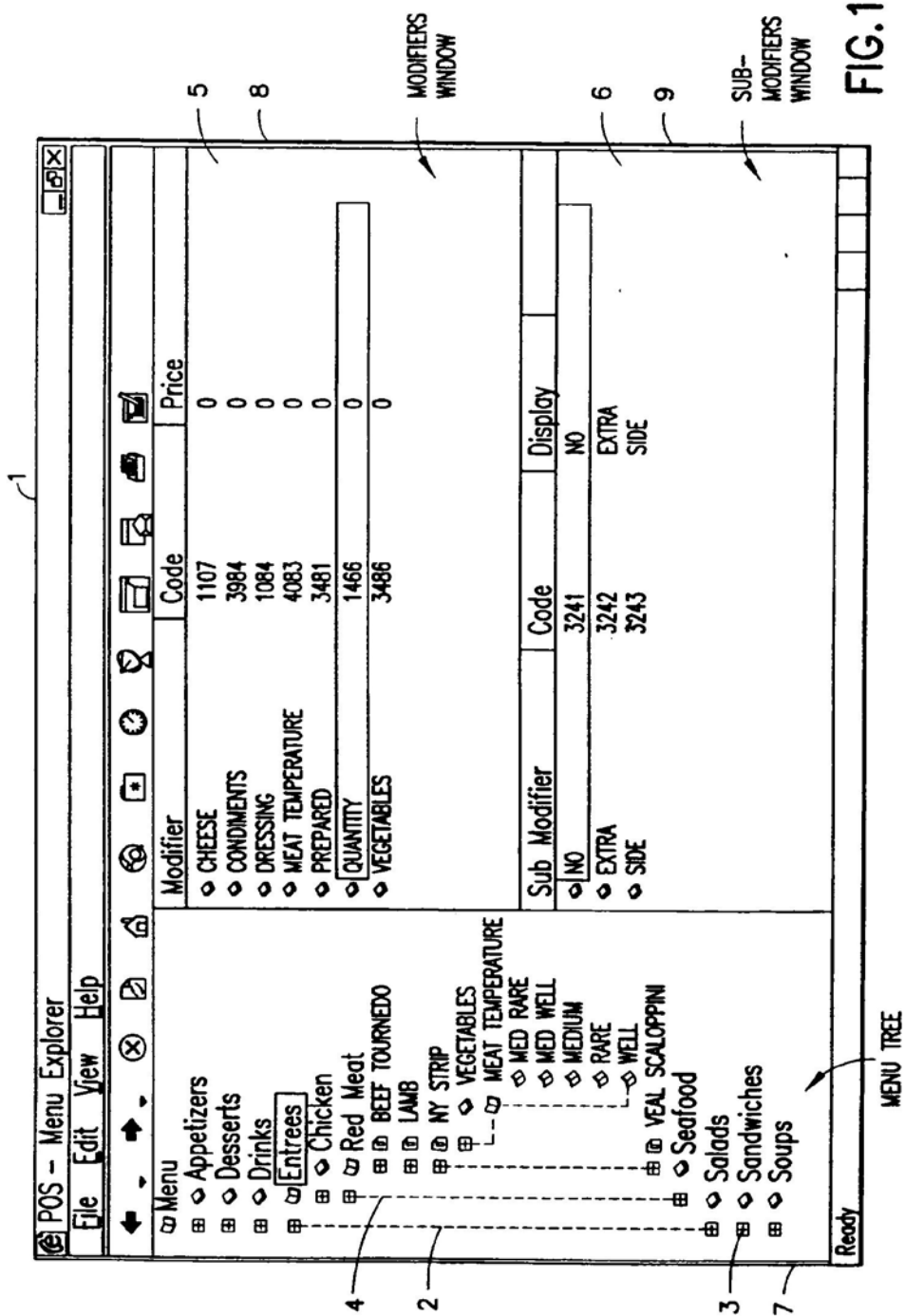
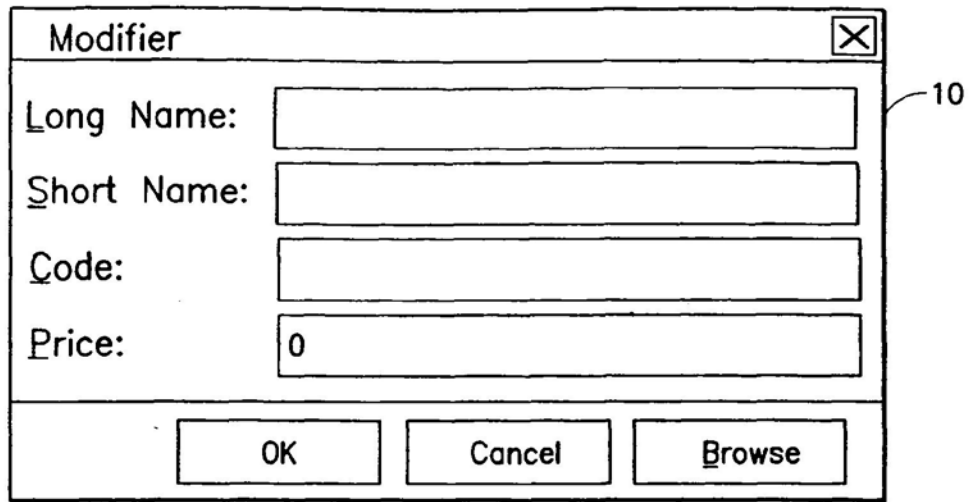
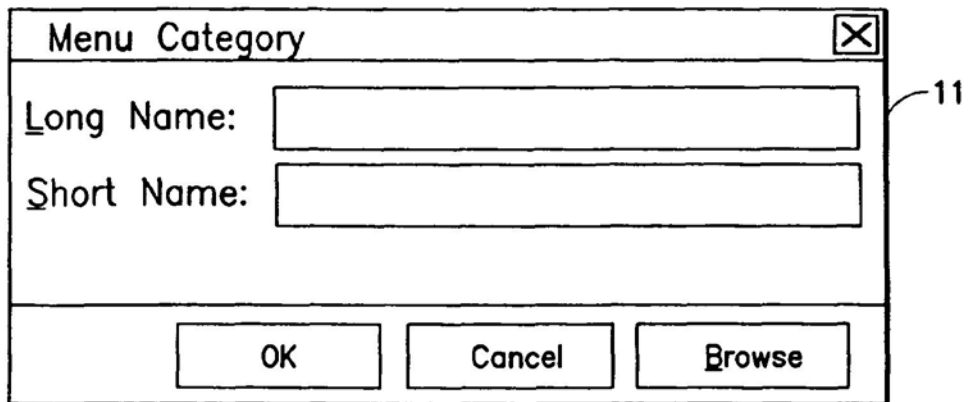

FIG. 1



A dialog box titled "Modifier" with a close button (X) in the top right corner. It contains four input fields: "Long Name:", "Short Name:", "Code:", and "Price:". The "Price:" field contains the number "0". At the bottom, there are three buttons: "OK", "Cancel", and "Browse". A reference numeral "10" is positioned to the right of the dialog box.

FIG.2



A dialog box titled "Menu Category" with a close button (X) in the top right corner. It contains two input fields: "Long Name:" and "Short Name:". At the bottom, there are three buttons: "OK", "Cancel", and "Browse". A reference numeral "11" is positioned to the right of the dialog box.

FIG.3

Menu Item

Long Name: Code:

Short Name: Price: Prep. Time:

Recipe

Flame broiled brandy marinated Tender Chicken Breast topped with a creamy cilantro sauce. Served with steamed broccoli, carrots and zucchini.
Spices include lemon pepper, paprika, ginger.

12

FIG. 4

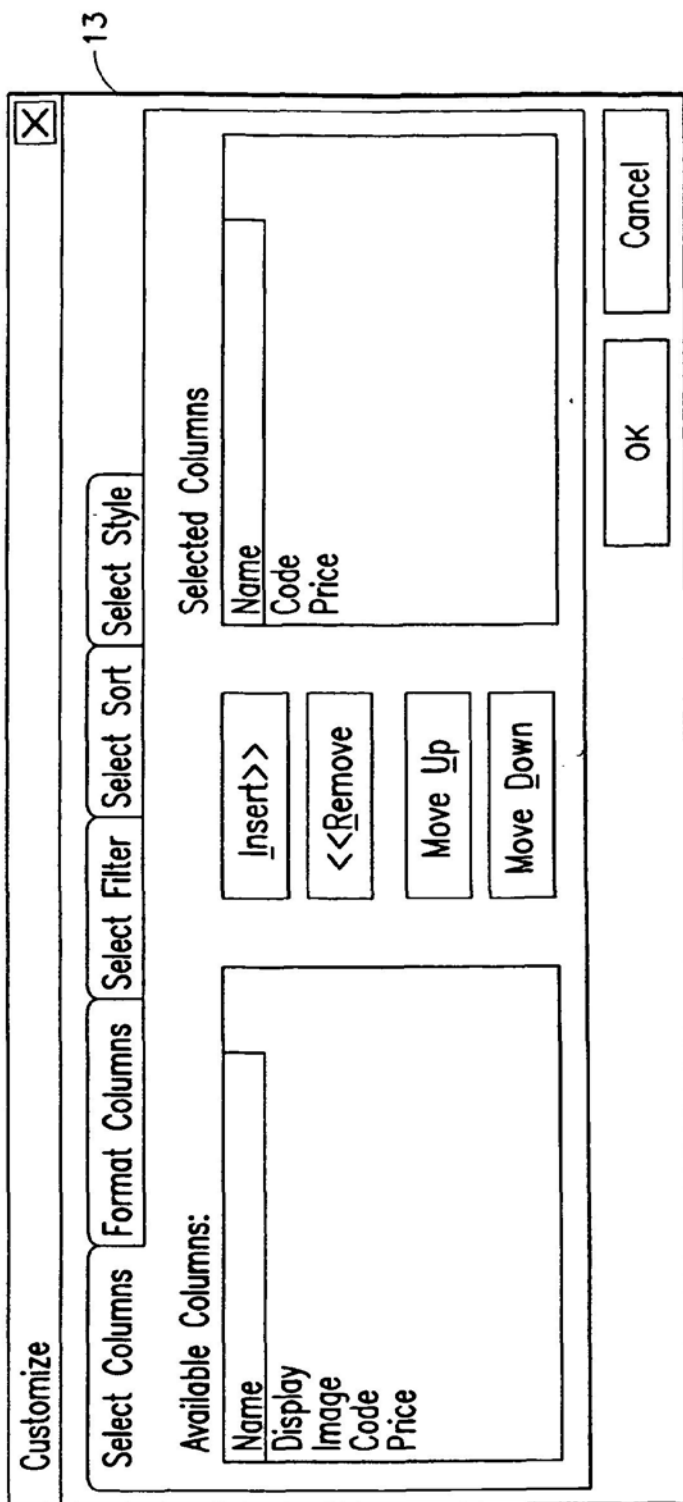

FIG.5

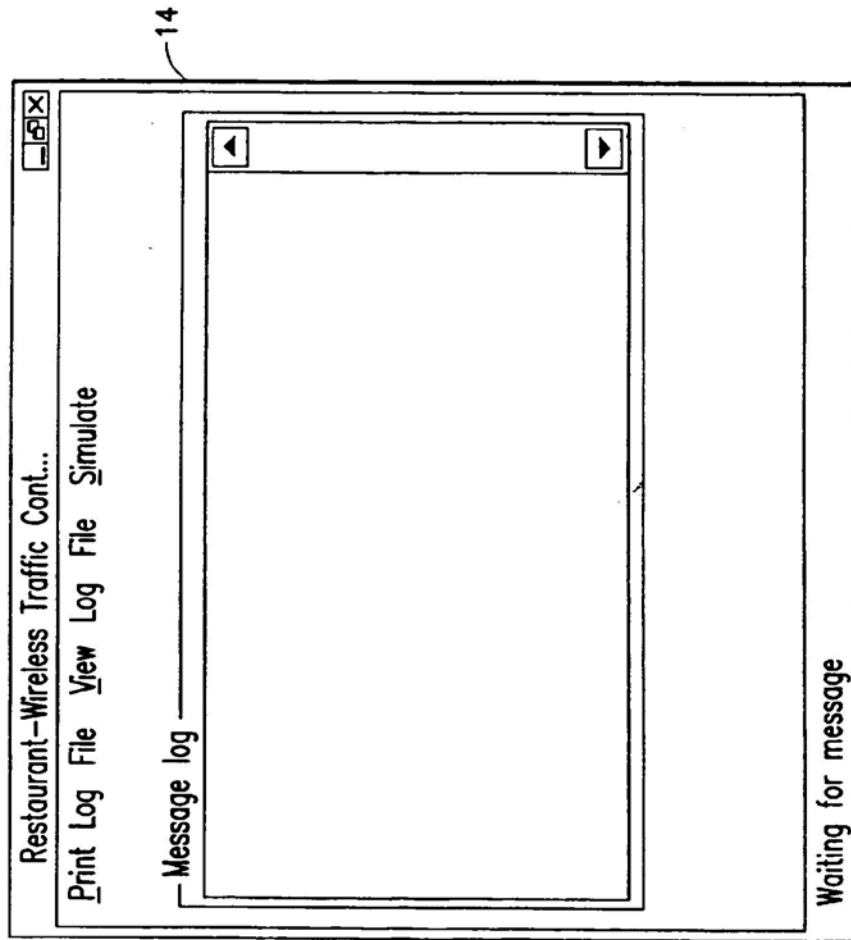

FIG. 6

The screenshot shows a window titled "POSce-System" with a close button in the top-left corner. Below the title bar is a menu bar with buttons for "Login", "CHECKS", "ORDER", "VIEW", and "PAY". The main content area is divided into several sections:

- Choose Item:** A grid of buttons for menu items. The first row contains "App", "Dessert", "Drinks", and "Entrees". The second row contains "Salads", "Sdwch", "Soups", and an empty button. The third and fourth rows each contain two empty buttons.
- Direction:** A section with buttons for "MAIN", "PREV", "PAGE", and "MODS".
- Select Guest to Order for:** A section with a label "1" above a text input field containing the number "2".
- Last Selection:** A section with a label "Last Selection" above a text input field containing "REMOVE LAST".

At the bottom of the window are three buttons: "OK", "Cancel", and "Browse".

Reference numerals 15 and 16 are present in the original image. 15 points to the "Choose Item" grid, and 16 points to the "Direction" section.

FIG. 7

INFORMATION MANAGEMENT AND SYNCHRONOUS COMMUNICATIONS SYSTEM WITH MENU GENERATION

FIELD OF THE INVENTION

This invention relates to an information management and synchronous communications system and method for generation of computerized menus for restaurants and other applications with specialized display and synchronous communications requirements related to, for example, the use of equipment or software with non-PC-standard graphical formats, display sizes and/or applications for use in remote data entry, information management and synchronous communication between host computer, digital input device or remote pager via standard hardwired connection, the internet, a wireless link, smart phone or the like.

BACKGROUND OF THE INVENTION

While computers have dramatically altered many aspects of modern life, pen and paper have prevailed in the hospitality industry, e.g., for restaurant ordering, reservations and wait-list management, because of their simplicity, ease of training and operational speed. For example, ordering prepared foods has historically been done verbally, either directly to a waiter or over the telephone, whereupon the placed order is recorded on paper by the recipient or instantly filled.

Although not previously adapted for wide-scale use in the hospitality industry, various forms of digital wireless communication devices are in common use, e.g., digital wireless messengers and pagers. Also in common use are portable laptop and handheld devices. However, user-friendly information management and communication capability not requiring extensive computer expertise has not heretofore been available for use in everyday life such as for restaurant ordering, reservations and wait-list management. Hundreds of millions of dollars have been spent on personal digital assistant ("PDA") development seeking to produce a small, light-weight and inexpensive device that could be adapted to such uses; yet none have yielded a satisfactory solution.

One of the inherent shortcomings of PDA type devices is that, as they strive for small size, low weight and low cost, they must compromise the size and clarity of the operator display medium interface itself, which in most cases is one of a variety of LCD (liquid crystal display) type devices. As the size of the display shrinks, the amount of information that may be displayed at any one point or time is commensurately decreased, typically requiring multiple screens and displays to display information to the operator. This reduces the overall utility of the device. Additionally, the smaller display and keyboard results in a non-optimal operator interface, which slows down operation and is thus unacceptable for the time criticality of ordering, reservation and wait-list management and other similar applications. This necessitates many design compromises which in the aggregate have resulted in limited acceptance of PDA type devices in the restaurant and hospitality fields.

Many of the negatives prevalent in earlier devices have been eliminated, but, to date, there is still no integrated solution to the ordering/waitlist/reservation problem discussed above. With the advent of the Palm® and other handheld wireless devices, however, the efforts to make such devices ubiquitous have begun to bear fruit at least in some areas, e.g., personal calendars. However, substantial use of such devices in the restaurant and hospitality context has not occurred to date. As discussed above, at least one of the

reasons PDAs have not been quickly assimilated into the restaurant and hospitality industries is that their small display sizes are not readily amenable to display of menus as they are commonly printed on paper or displayed on, e.g., large, color desktop computer screens. Another reason is that software for fully realizing the potential for wireless handheld computing devices has not previously been available. Such features would include fast and automatic synchronization between a central database and multiple handheld devices, synchronization and communication between a World Wide Web ("Web") server and multiple handheld devices, a well-defined application program interface ("API") that enables third parties such as point of sale ("POS") companies, affinity program companies and internet content providers to fully integrate with computerized hospitality applications, real-time communication over the internet with direct connections or regular modem dialup connections and support for batch processing that can be done periodically throughout the day to keep multiple sites in synch with the central database. A single point of entry for all hospitality applications to communicate with one another wirelessly has also previously been unavailable. Such a single point of entry would work to keep all wireless handheld devices and linked Web sites in synch with the backoffice server (central database) so that the different components are in equilibrium at any given time and an overall consistency is achieved. For example, a reservation made online would be automatically communicated to the backoffice server and then synchronized with all the wireless handheld devices wirelessly. Similarly, changes made on any of the wireless handheld devices would be reflected instantaneously on the backoffice server, Web pages and the other handheld devices.

For the foregoing reasons, paper-based ordering, waitlist and reservations management have persisted in the face of widespread computerization in practically all areas of commerce. At most, computerization of these functions has been largely limited to fixed computer solutions, i.e., desktop or mainframe, because of the problems heretofore faced in configuring wireless handheld devices and maintaining database synchronization for such applications. Specifically, the unavailability of any simple technique for creating restaurant menus and the like for use in a limited display area wireless handheld device or that is compatible with ordering over the internet has prevented widespread adoption of computerization in the hospitality industry. Without a viable solution for this problem, organizations have not made the efforts or investments to establish automated interfaces to handheld and Web site menus and ordering options.

A principal object of the present invention is to provide an improved information management and synchronous communications system and method which facilitates user-friendly and efficient generation of computerized menus for restaurants and other applications that utilize equipment with non-PC-standard graphical formats, display sizes and/or applications.

A further object of the present invention is to provide an improved information management and synchronous communications system and method which provides for entry, management and communication of information from the operator as well as to and from another computer, Web page menu, remote digital device using a standard hardwired connection, the internet or a wireless link.

A further object of the present invention is to provide an improved information management and synchronous communications system which is small, affordable and light-weight yet incorporates a user-friendly operator interface and displays menus in a readily comprehensible format.

A further object of the present invention is to provide a synchronous information management and communications system which enables automatic updating of both wireless and internet menu systems when a new menu item is added, modified or deleted from any element of the system.

SUMMARY OF THE INVENTION

The foregoing and other objects of the present invention are provided by a synchronous information management and communications system and method optimized for simplicity of operation which incorporates menu generation for creation of menus to be used with wireless remote handheld computer and PDA devices, the internet or any application where simple and efficient generation of menus is appropriate. The menu generation approach of the present invention includes a desktop software application that enables the rapid creation and building of a menu and provides a means to instantly download the menu configuration onto, e.g., a handheld device or Web page and to seamlessly interface with standard point of sale ("POS") systems to enable automatic database updates and communication exchanges when a change or input occurs in any of the other system elements. To solve the above and other related problems, an information management and communications system is provided which results in a dramatic reduction in the amount of time, and hence cost, to generate and maintain computerized menus for, e.g., restaurants and other related applications that utilize non-PC-standard graphical formats, display sizes or applications.

The menu generation approach of the present invention has many advantages over previous approaches in solving the problem of converting paper-based menus or Windows® PC-based menu screens to small PDA-sized displays and Web pages. In one embodiment, the present invention is a software tool for building a menu, optimizing the process of how the menu can be downloaded to either a handheld device or Web page, and making manual or automatic modifications to the menu after initial creation.

The use of wireless handheld devices in the restaurant and hospitality industry is becoming increasingly pervasive as restaurant owners and managers become more aware of the benefits. With the proper wireless handheld system in place, restaurants can experience increased table turns from improved server productivity and shorter order taking and check paying times. Restaurants and POS companies seeking to provide a wireless handheld interface to their desktop-based POS systems or a Web page equivalent face several challenges. These challenges include building a menu using their existing database and transferring the menu onto handheld devices or Web pages that will interface with servers wirelessly or to restaurants/customers over the internet. The menu generation approach of the present invention is the first coherent solution available to accomplish these objectives easily and allows one development effort to produce both the handheld and Web page formats, link them with the existing POS systems, and thus provides a way to turn a complicated, time-consuming task into a simple process.

The information management and synchronous communications system of the present invention features include fast synchronization between a central database and multiple handheld devices, synchronization and communication between a Web server and multiple handheld devices, a well-defined API that enables third parties such as POS companies, affinity program companies and internet content providers to fully integrate with computerized hospitality applications, real-time communication over the internet with

direct connections or regular modem dialup connections and support for batch processing that can be done periodically throughout the day to keep multiple sites in synch with the central database.

The communication module also provides a single point of entry for all hospitality applications, e.g., reservations, frequent customer ticketing, wait lists, etc. to communicate with one another wirelessly and over the Web. This communication module is a layer that sits on top of any communication protocol and acts as an interface between hospitality applications and the communication protocol and can be easily updated to work with a new communication protocol without modifying the core hospitality applications. A single point of entry works to keep all wireless handheld devices and linked web sites in synch with the backoffice server applications so that the different components are in equilibrium at any given time and an overall consistency is achieved. For example, a reservation made online can be automatically communicated to the backoffice server and then synchronized with all the wireless handheld devices wirelessly. Similarly, changes made on any of the wireless handheld devices are reflected instantaneously on the backoffice server Web pages and the other handheld devices.

BRIEF DESCRIPTION OF THE DRAWINGS

The foregoing features and advantages of the present invention can be appreciated more fully from the following description, with references to the accompanying drawings in which:

FIG. 1 is a schematic representation of a window displayed on a computer display screen which shows a hierarchical tree menu, modifier window and sub-modifier window in conformity with a preferred embodiment of the present invention.

FIG. 2 is a schematic representation of a modifier dialog box in conformity with a preferred embodiment of the present invention.

FIG. 3 is a schematic representation of a menu category dialog box in conformity with a preferred embodiment of the present invention.

FIG. 4 is a schematic representation of a menu item dialog box in conformity with a preferred embodiment of the present invention.

FIG. 5 is a schematic representation of a display customization dialog box in conformity with a preferred embodiment of the present invention.

FIG. 6 is a schematic representation of a communications control window in conformity with a preferred embodiment of the present invention.

FIG. 7 is a schematic representation of a point of sale interface on a wireless handheld device for use in displaying page menus created in conformity with a preferred embodiment of the present invention.

DETAILED DESCRIPTION OF THE INVENTION

Most personal computers today run under an operating system that provides a graphical user interface ("GUI") for accessing user applications. A GUI is used in the preferred embodiment of the present invention. Through an interface of windows, pull-down menus, and toolbars, GUI operating systems have simplified PCs and have rendered computer technology more user friendly by eliminating the need to memorize keyboard entry sequences. In addition, GUIs allow users to manipulate their data as they would physical

5

entities. For example, a window can represent a file and the contents of the window can represent the records of the file. The window can be opened, closed, or set aside on a desktop as if it were an actual object. The records of the file can be created, deleted, modified and arranged in a drag-and-drop fashion as if they also were physical objects. The most common GUI operating systems that provide this "object-oriented" environment for personal computers are Microsoft Windows® systems, including Windows CE® for handheld wireless devices and the like. Generally, a particular application program presents information to a user through a window of a GUI by drawing images, graphics or text within the window region. The user, in turn, communicates with the application by "pointing" at graphical objects in the window with a pointer that is controlled by a hand-operated pointing device, such as a mouse, or by pressing keys on a keyboard.

The use of menus is conventional in GUIs for software applications. Menus are typically utilized to provide end users of applications with available choices or processing options while using the applications. For example, in a typical desktop or interactive application, selection of a "file" from a menu bar may cause display of a context menu which provides "file" options. File options can have additional subordinate or child options associated with them. If a file option having subordinate options is selected, the child options are displayed in context in a child menu or submenu proximate to the selected parent option. One or more of the child options provided in the child menu may have further subordinate options. Thus, such a menu system comprises cascading sets of menus which are displayable in context to show the parent/child relationships between options of the context menu. A menu system of this type is incorporated into the preferred embodiment of the invention.

The preferred embodiment of the present invention uses typical hardware elements in the form of a computer workstation, operating system and application software elements which configure the hardware elements for operation in accordance with the present invention. A typical workstation platform includes hardware such as a central processing unit ("CPU"), e.g., a Pentium® microprocessor, RAM, ROM, hard drive storage in which are stored various system and application programs and data used within the workstation, modem, display screen, keyboard, mouse and optional removable storage devices such as floppy drive or a CD ROM drive. The workstation hardware is configured by software including an operating system, e.g., Windows® 95, 98, NT or CE, networking software (including internet browsing software) and application software components. The preferred embodiment also encompasses a typical file server platform including hardware such as a CPU, e.g., Pentium® microprocessor, RAM, ROM, hard drive, modem, and optional removable storage devices, e.g., floppy or CD ROM drive. The server hardware is configured by software including an operating system, e.g., Windows® 95, 98, NT or CE, networking software (including Web server software) and database software.

A computer workstation for use in the preferred embodiment also includes a GUI. As is conventional, the GUI is configured to present a graphical display on the display screen arranged to resemble a single desktop. Execution of an application program involves one or more user interface objects represented by windows and icons. Typically, there may be several windows and icons simultaneously present on the desktop and displaying information that is generated by different applications.

The window environment is generally part of the operating system software that includes a collection of utility programs for controlling the operation of the computer system. The computer system, in turn, interacts with appli-

6

cation programs to provide higher level functionality, including a direct interface with the user. Specifically, the application programs make use of operating system functions by issuing task commands to the operating system which then performs the requested task. For example, an application program may request that the operating system display certain information on a window for presentation to the user.

An aspect of the preferred embodiment of the information management and communications system of the invention is shown in FIG. 1. FIG. 1 shows an example of the GUI provided by the operating system of the preferred embodiment of the present invention. With reference to FIG. 1, the preferred embodiment includes an intuitive GUI 1 from which to build a menu on a desktop or other computer. A hierarchical tree structure 2 is used to show the different relationships between the menu categories 3 (e.g., soups, salads, appetizers, entrees, deserts, etc.), menu items 4 (e.g., green salad, chicken caesar salad, etc.), menu modifiers 5 (e.g., dressing, meat temperature, condiments, etc.) and menu sub-modifiers 6 (e.g., Italian, French, ranch, bleu cheese, etc.).

The procedure followed in configuring a menu on the desktop PC and then downloading the menu configuration onto the POS interface on the handheld device in conformance with the preferred embodiment is as follows.

The menu configuration application is launched by clicking on the appropriate icon on the desktop display screen. FIG. 1 will then be displayed. There are three windows on the screen shown in FIG. 1. The left window is the menu tree 7, also called the tree view. The top right window is the Modifiers window 8 and the bottom right window is the Sub-Modifiers window 9. The Sub-Modifiers window lists the sub-modifiers that correspond to the modifier that is selected. The views on the right are referred to as list views. There are several ways of invoking a command, including using the menu options; using the context menu (right mouse click); using the keyboard or using the toolbar icons. For example, if it is desired to add a category to the menu, the following four options are available: (1) clicking on Edit, Add Category; (2) right mouse clicking on Menu, then clicking on Add Category; (3) highlighting Menu, then typing Ctrl+T or (4) clicking on the Add Category icon on the toolbar. To add an item to a category, the following options are available: (1) highlighting the category to which it is desired to add an item and then clicking on Edit>Add Item; (2) right mouse clicking on the desired category and then clicking on Add Item; (3) highlighting the desired category, then typing Ctrl+N or (4) clicking on the Add icon on the toolbar.

When building a menu, it should be kept in mind that the menu items are stored using a tree metaphor similar to how files are stored on a PC with folders and subfolders. The menu structure is similar to the Windows® File Explorer in the way the items are organized hierarchically. Below is an example of how an item may be configured:

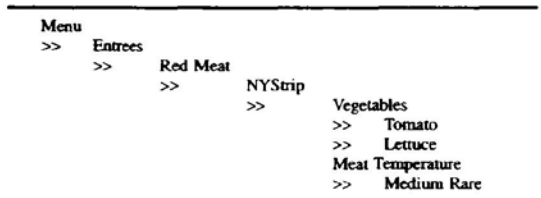

In the above example, Menu is the root. Entrees is a menu category. Red Meat is an Entree category. NY Strip is a

modifier. Vegetable is a modifier. Meat Temperature is a modifier. Medium Rare is a sub-modifier of Meat Temperature.

The steps taken in building a menu are as follows:

1. Add Modifiers;
2. Add Sub-Modifiers and link them to the Modifiers;
3. Create Menu categories;
4. Add menu items to the categories;
5. Assign Modifiers to the menu items;
6. Preview the menu on the POS emulator on the desktop PC;
7. Download the menu database to the handheld device.

To add modifiers, a user clicks on the inside of the Modifiers window, then (1) clicks on Edit>Add Modifier, (2) Presses Ctrl+N; (3) right mouse clicks in the Modifiers window, then clicks on Add Modifiers or (4) clicks on the Add icon from the toolbar. If a menu is being built from scratch, the procedure is to enter the Long Name, Short Name, Code and Price in the Modifier dialog box 10 shown in FIG. 2. The Long Name is the full descriptive name of the item. The Short Name is the abbreviated name that will be displayed on the handheld device. The Code is the numeric or alphanumeric code for the item. If there is an existing database, the existing database can be browsed and menu items retrieved from the database. Clicking on the Browse button will bring up the existing database of menu items. The item to be added is then selected and "OK" is clicked. The fields will then be filled with the information from the database. Clicking on OK again will add the item as a modifier. To delete a modifier, the modifier is selected and the Delete key pressed on the keyboard. To edit a modifier, either the modifier is double clicked or the Enter key is pressed.

Sub-modifiers represent the last level of modifiers that can be assigned to a menu tree. To add sub-modifiers, the modifier to which sub-modifiers are to be assigned is selected. Then, the focus is set on the sub-modifier window by clicking inside the Sub-Modifier window as follows: (1) clicking on Edit>Add Sub-Modifier; (2) pressing Ctrl+N; (3) right mouse clicking in the Sub-Modifiers window, then clicking on Add Sub-Modifiers or (4) clicking on the Add icon from the toolbar. If a menu is being built from scratch, the procedure is to enter the Long Name, Short Name, Code and Price in a Sub-Modifier dialog box similar to the Modifier dialog box shown in FIG. 2. As with modifiers, the Long Name is the full descriptive name of the item. The Short Name is the abbreviated name that will be displayed on the handheld device. The Code is the numeric or alphanumeric code for the item. As before, if there is an existing database, the existing database can be browsed and menu items retrieved from the database. Clicking on the Browse button will bring up the existing database of menu items. The item to be added is then selected and OK clicked. The fields will then be filled with the information from the database. Clicking on OK again will add the item as a sub-modifier. To delete a sub-modifier, the sub-modifier is selected and the Delete key depressed on the keyboard. To edit a sub-modifier, either the sub-modifier is double clicked or the Enter key is pressed.

Menu categories are created from the root. Some examples of categories are Appetizers, Soups, Salads, Entrees, Desserts, etc. The first step is to click on Menu in the menu tree window. Categories are added by (1) clicking on the Add Category icon from the toolbar; (2) clicking on Edit>Add Category or (3) pressing Ctrl+T. As shown in FIG. 3, Menu Category dialog box 11 then appears in which to enter the Long and Short names for the menu category.

To add menu items to categories, the menu category which is being built is clicked. For example, if items are being added to Appetizers, the Appetizers branch is clicked on. Then the Edit>Add Item is clicked on or Ctrl+N pressed.

As before, if a menu is being built from scratch, the procedure is to enter the Long Name, Short Name, Code, Prep Time, Recipe and Price into the Menu Item dialog box 12 shown in FIG. 4. The Long Name is the full descriptive name of the item. The Short Name is the abbreviated name that will be displayed on the handheld device. The Code is the numeric or alphanumeric code for the item. Prep Time is the time it takes to prepare the meal and Recipe would include preparation methods and ingredients that are used in the preparation of the item. If there is an existing database, the existing database can be browsed and menu items retrieved from the database. Clicking on the Browse button will bring up the existing database of menu items. The item to be added is then selected and OK is clicked. The fields will then be filled with the information from the database. Clicking on OK again will add the item to the category.

Once the menu items have been entered, it may be desired to assign some modifiers to the menu items. For example, it may be desired to assign meat temperature to a steak order. To accomplish this, first the modifier to be assigned is selected, then the menu item on the tree view that is to be assigned the modifier is clicked on and then Edit>Assign Modifier is clicked on. Or, the modifier can simply be dragged and dropped onto the menu item to link them. A dialog box is then displayed asking if this modifier is a required modifier. If it is a required modifier, the display icon will be red but if it is a non-required modifier the display icon will be green. As many modifiers as are applicable can be assigned. If any changes are made to the modifiers, those changes will be automatically reflected throughout the menu tree.

Once the modifiers have been entered, it may be desired to assign sub-modifiers to the modifiers items. For example, it may be desired to add Honey Mustard as a sub-modifier to Dressing. To accomplish this, first the modifier to be assigned a sub-modifier is selected, then the sub-modifier window is clicked on, then Edit>Add Sub Modifier is clicked on, Ctrl+N entered or the Add icon from the toolbar is clicked on. Or, the sub-modifier can simply be dragged and dropped onto the modifier to link them.

When the menu has been completely configured, it can be previewed on a POS emulator on the desktop to verify that the menu is correctly configured before downloading it to the handheld device. To preview, File>Preview Database is clicked on or the Preview Database icon from the toolbar is clicked on. The handheld POS emulator on the desktop can then be run. If the configuration is deemed acceptable, the handheld device is connected to the desktop PC to ensure that a connection has been established; the POS application on the handheld device is exited and File>Download Database is clicked on or the Download Database icon from the toolbar is clicked on. If there is an existing menu database on the handheld device, the system will ask if the existing database should be replaced. Yes is clicked if existing database replacement is desired.

A database function enables the creation of, e.g., a breakfast menu, lunch menu and dinner menu and downloading them to a handheld device. Functions available are (1) creating a new database; (2) opening an existing database; (3) saving a database under a different name. To access these functions, File is clicked on the menu bar.

The preferred embodiment encompasses customized layout, views and fonts. To set the focus on the view it is

desired to change, click inside the desired window. The main customizing dialog box is accessed by clicking on View>Customize View. A dialog box 13, as shown in FIG. 5, will be displayed including tabs that allow the following options: selection of Columns to display in the list view by choosing and arranging the fields to display in the Modifiers and Sub-Modifiers windows; formatting Columns by specifying the column widths and justification; selecting Filter fields restricting the list to display only the items that meet certain criteria For example, display of modifiers with codes between 500 and 550. Selecting Sort allows sorting the modifiers or sub-modifiers according to any of the available fields such as Name, Code or Price. Selecting Style facilitates choice of font type, style, size, etc. To change the font in a particular window, click on View>Fonts or right mouse click in the desired window and then click on Fonts. To change the size of the windows, drag the borders of the windows to expand or contract the size of the windows. To change the column widths, simply drag the edge of the column headers to increase or decrease the column widths.

A communications control program monitors and routes all communications to the appropriate devices. It continuously monitors the wireless network access point and all other devices connected to the network such as pagers, remote devices, internet Web links and POS software. Any message received is decoded by the software, and then routed to the appropriate device. No user action is needed during operation of the software once the application has been launched. To launch the communications control module, a Wireless Traffic icon is clicked on the desktop PC. When the program loads, the screen shown in FIG. 6 appears. Messages received are logged in the window 14 shown in FIG. 6 with a time stamp. The messages are also logged to a file on the hard drive. This provides a mechanism to monitor all traffic across the network (possibly useful for troubleshooting, or maintenance, but not necessary for normal operation). The program may be minimized so the screen is not displayed on the desktop, but it must be running for proper communications to exist between all devices on the network.

As stated, the preferred embodiment of the present invention includes the use of and compatibility with GUI technology. A drag-and-drop approach is used for organizing the tree structure 2 in the generated menu. Drag-and-drop is also used for assigning modifiers (modifiers can be dragged from the modifiers window 5 and dropped onto the menu item 4 for assignment). In-cell editing results in fast editing of items in building the menus. Customizable fonts enable users to change font types, style and size. Customizable layouts enable users to resize windows, change icons and display preferences. The inventive approach provides for fully persistent storage between sessions, even if a session is improperly or abruptly terminated. Font and the tree state (i.e., which nodes are expanded/collapsed) are stored between sessions. Layout for modifiers and sub-modifiers list views (filter, columns, formatting, font, etc.) are stored between sessions. The last database used is likewise stored between sessions. Splitter views allow the user to see different views at the same time. Each view is displayed on its own section of the screen. Views can be resized via the keyboard or a mouse by simply dragging the splitter in the middle.

An automated function is provided to import existing POS databases into the inventive menu generation system and, as discussed above with respect to the detailed example of how to use the preferred embodiment, an automated download procedure is provided to transfer the desktop database onto

a handheld device and/or Web page. Also as discussed, the preferred embodiment facilitates preview of the handheld device or Web page version of the POS menu on the desktop before downloading and configuration. Customizable desktop menu generation is contemplated, as discussed above, in the form of customizable fonts, columns, layouts, etc. The inventive approach also includes templates for common modifiers that can be assigned to similar menu items. The preferred embodiment also supports multiple databases, thus providing for the creation and storing of different menu databases on handheld devices such as breakfast, lunch or dinner menus. The user can then select the appropriate database to reflect the time of day.

FIG. 7 is a schematic representation of a point of sale interface 15 for use in displaying a page-type menu 16 created using the inventive menu generation approach. As can be seen from FIG. 7, the page menu is displayed in a catalogue-like point-and-click format whereas the master menu, FIG. 1, is displayed as a hierarchical tree structure. Thus, a person with little expertise can "page through" to complete a transaction with the POS interface and avoid having to review the entire menu of FIG. 1 to place an order. A PDA or Web page format could appear like FIG. 7 or the display could be configured for particular requirements since fully customizable menu generation and display are contemplated.

The POS interface on the handheld device supports pricing in the database or querying prices from the POS server. The POS device also can be customized with respect to "look and feel" for the particular version. As can be seen in FIG. 7, the POS interface provides for billing, status and payment with respect to orders. A myriad of options can be provided depending on the application.

Advanced database functions are provided in the preferred embodiment of the invention, including an automated download process onto handheld devices and/or Web sites. In the preferred embodiment, the menu generation system of the present invention uses an API called ActiveX Data Objects ("ADO") for database access. ADO is useful in a variety of settings. It is built on top of OLE DB and can be used to talk to databases and, in the future, any data source with any OLE DB driver. Advanced querying is supported. The database can be queried on virtually all fields. Queries can be built using SQL syntax for experienced users or can be created using a query builder which guides users through the creating process. Advanced error handling is supported. Errors occurring at run time can be trapped. A descriptive message is displayed to alert the user and provide error information. However, the application does not terminate when the errors happen. The source code is easy to maintain and modify, thus allowing for on time delivery of customized versions of the software. The advanced database functions produce well-designed databases that accommodate growth and scalability.

The inventive menu generation approach provides a solution for the pervasive connectivity and computerization needs of the restaurant and related markets. The inventive solution includes automatic database management and synchronization, PDA and handheld wireless operating system integration and optimization, wireless communications and internet connectivity, user interface design, and graphics design.

In the preferred embodiment, the menu generation approach of the present invention uses Windows CE® as the operating system for the handheld devices. Windows CE® provides the benefits of a familiar Windows 95/98/NT® look and feel, built-in synchronization between handheld

devices, internet and desktop infrastructure, compatibility with Microsoft Exchange®, Microsoft Office 9® and TCP/IP quick access to information with instant-on feature.

Windows CE® provides a basic set of database and communication tools for developer use. However, interfacing with these tools to provide application specific results can be a complex task. In addition to the menu generation described above, a set of software libraries described herein in conformance with the present invention not only enhances the basic Windows CE® functionality by adding new features but also maximizes the full potential of wireless handheld computing devices. Such features include fast synchronization between a central database and multiple handheld devices, synchronization and communication between a Web server and multiple handheld devices, a well-defined API that enables third parties such as POS companies, affinity program companies and internet content providers to fully integrate with computerized hospitality applications, real-time communication over the internet with direct connections or regular modem dialup connections and support for batch processing that can be done periodically throughout the day to keep multiple sites in synch with the central database.

The synchronous communications control module discussed above provides a single point of entry for all hospitality applications to communicate with one another wirelessly or over the Web. This communications module is a layer that sits on top of any communication protocol and acts as an interface between hospitality applications and the communication protocol. This layer can be easily updated to work with a new communication protocol without having to modify the core hospitality applications. The single point of entry works to keep all wireless handheld devices and linked Web sites in synch with the backoffice server (central database) so that the different components are in equilibrium at any given time and an overall consistency is achieved. For example, a reservation made online is automatically communicated to the backoffice server which then synchronizes with all the wireless handheld devices wirelessly. Similarly, changes made on any of the wireless handheld devices will be reflected instantaneously on the backoffice server and the other handheld devices.

The software applications for performing the functions falling within the described invention can be written in any commonly used computer language. The discrete programming steps are commonly known and thus programming details are not necessary to a full description of the invention.

A simple point-to-point wireless capability is contemplated which permits simple digital messages to be sent from the wireless handheld devices to a receiver in a beeper and/or valet parking base-station. The POS interface of FIG. 7 is representative of the display on a typical wireless device used in conformity with the invention. A simple protocol is used to acknowledge receipt of the message and thus simultaneous communication is not necessary, which reduces the cost of the wireless link. The range of the wireless link is determined by the characteristics of the radio transceiver. Adding a wireless link allows paging of beeper equipped customers directly from the operator interface on the wireless handheld devices and communication to and from various input/output transmitters and receivers to update the status of the order, reservation or other information and thus further reduce the workload on the operator and enable operations to proceed much faster. This link could also be hardwired or otherwise implemented using any two-way messaging transport.

A further aspect of the invention is the use of the menus generated in accordance with the described technique to place orders from wireless remote handheld devices or from remote locations through the internet. The World Wide Web is a distributed hypermedia computer system that uses the internet to facilitate global hypermedia communication using specified protocols. One such protocol is the Hypertext Transfer Protocol ("HTTP"), which facilitates communication of hypertext. Hypertext is the combination of information and links to other information. In the context of the Web, hypertext is defined by the Hypertext Mark-up Language ("HTML"). The links or hyperlinks in a HTML document reference the locations of resources on the Web, such as other HTML documents. Another language used in creating documents for use on the Worldwide Web, to display on computer screens, or to create speech style sheets for use in, e.g., telephones, is the Extensible Mark-Up Language ("XML"). XML is a "metalanguage", i.e., a language for describing languages which was developed to eliminate the restrictions of HTML.

The Web is a client-server system. The HTML documents are stored on Web server computers, typically in a hierarchical fashion with the root document being referred to as the home page. The client specifies a HTML document or other source on the server by transmitting a Uniform Resource Locator ("URL") which specifies the protocol to use, e.g., HTTP, the path to the server directory in which the resource is located, and filename of the resource. Users retrieve the documents via client computers. The software running on the user's client computer that enables the user to view HTML documents on the computer's video monitor and enter selections using the computer's keyboard and mouse is known as a browser. The browser typically includes a window in which the user may type a URL. A user may cause a URL to be transmitted by typing it in the designated window on the browser or by maneuvering the cursor to a position on the displayed document that corresponds to a hyperlink to a resource and actuating the mouse button. The latter method is commonly referred to simply as "clicking on the hot-spot" or "clicking on the hyperlink". The hyperlink methodology is contemplated for use in accordance with the preferred embodiment to transmit orders via the internet. Web server application software exists that enables a user to shop for and order merchandise. Such systems are sometimes referred to as electronic merchandising systems or virtual storefronts. Systems that enable a user to choose among several retailers' goods are sometimes referred to as electronic malls. An electronic retailer's or electronic mall operator's Web server provides HTML forms that include images and descriptions of merchandise. The user may conventionally search for an item by entering a key word search query in a box on a form. When a user selects an item, the server may provide a linked form that describes that item in further detail. The user may also conventionally enter ordering information into boxes on the form, such as the type and quantity of the item desired. The information entered by the user is transmitted to the server. The user may select multiple items in this manner and then enter a credit card number to pay for the purchases. The retailer processes the transaction and ships the order to the customer. As can be appreciated, ordering merchandise can also be done from menus. The generation of menus of items or merchandise for sale over the internet is readily accomplished by the menu generation approach of the present invention.

Searching for items that the user is interested in purchasing is insufficient in prior merchandising systems. Database

13

management programs use index searching to facilitate rapid searching of large amounts of data. The creator of the database may instruct the program to use specified fields in the database as indexed or key fields. The program locates all terms in the database that appear in the indexed fields and stores them in an index table. Each entry in the index table includes a term and corresponding pointer to the location in the database where the term is found. If a user initiates a search for a term that is present in the index table, the program can locate the instances of that term in the database with exceptional speed. Users who are familiar with the particular database they are searching will generally know which fields are indexed and will know the format of the data in those fields. For example, a user of a database containing the inventory of a bookstore may know that users can search for the names of authors of books and that a user who wishes to do so should enter the author's last name first. A user having such knowledge will therefore be able to search efficiently. Users of electronic merchandising systems, however, are generally end-consumers who have no knowledge of a merchant's database. If, as is very likely, such a user initiates a search for a term that is not present in the index table, the program must sequentially search through all records in the database. Sequential records are typically linked by pointers. Using pointers in this manner is very demanding on server resources, resulting not only in an exceptionally slow search, but also creating a bottleneck for other processes that the server may be executing. The menu generation approach of the present invention can be used to create customized menus from a database that includes every item of merchandise the vendor has for sale. In this manner, customers can scan the generated menu much more readily than they could view the entire database and the necessity of having familiarity with the database is eliminated as well, reducing the need for resource intensive pointers.

While the preferred embodiment of the invention is for the generation of restaurant menus and the like, the broad scope of the invention is far greater. For example, menus generated in accordance with the invention can be used in the desktop computing environment in association with the operating system or application programs. One such use is to facilitate the creation of user personalized file structures for general desktop use. Another use is to facilitate the location of customized menus from master menus for use in association with application software to make the execution of the application software more efficient by, e.g., eliminating the necessity of querying or checking every tree branch in the master menu file structure in response to user input or other criteria and to create handheld/PDA compatible versions of the software.

While the preferred embodiment of the invention includes the selection of items from a master menu wherein the master menu is displayed using a graphical user interface, it is to be appreciated that any means for displaying the master menu to the user and generating another menu in response to and comprised of the selections made is encompassed by the contemplated invention. The invention encompasses the selection of nontextual symbols, characters, icons and the like, in addition to text, from a hierarchical tree menu or the like for generation of another menu comprised of such items.

It is also within the scope of the invention to generate menus automatically in response to predetermined criteria. For example, in the restaurant menu generation embodiment, a modified menu can be generated to comply with a particular specification or group of criteria such as, e.g., "dinner", "low cholesterol", "low fat", "fish",

14

"chicken", or "vegetarian". In this embodiment, only items from the master menu that satisfy specified parameters will be included in the generated menu. The selection process could involve selection of master menu items based on tags or identifiers associated with the items or by checking every master menu item against a dictionary of items acceptable for inclusion in the modified menu. It should also be appreciated that the invention encompasses any combination of automatic and manual user selection of the items comprising the generated menu. For example, a user might specify criteria which would further control automatic selection or the user could manually select some items with automatic selection of others. The menu generation aspect of the invention is equally applicable to table-based, drive-thru, internet, telephone, wireless or other modes of customer order entry, as is the synchronous communications aspect of the invention.

The inventive concept encompasses the generation of a menu in any context known to those skilled in the art where an objective is to facilitate display of the menu so as to enable selection of items from that menu. The restaurant menu generation embodiment is but one example of a use for the inventive concept. Likewise, displaying menus generated in accordance with the invention on PDAs and Web pages to facilitate remote ordering are but a few examples of ways in which such a menu might be used in practice. Any display and transmission means known to those skilled in the art is equally usable with respect to menus generated in accordance with the claimed invention.

In the more general situation, menus can be generated in accordance with the present invention in a variety of situations. For example, the usable file structure for a particular data processing application can be dictated by the user or an application program prior to or during the execution of the application program. Efficiencies with respect to computational speed and equipment, e.g., storage and processor, usage can thus be achieved along with the facilitation of display of the generated menu.

While the best mode for carrying out the preferred embodiment of the invention has been illustrated and described in detail, those familiar with the art to which the invention relates will recognize various alternative designs and embodiments which fall within the spirit of practicing the invention. The appended claims are intended to cover all those changes and modifications falling within the true spirit and scope of the present invention.

That which is claimed is:

1. An information management and synchronous communications system for generating and transmitting menus comprising:

- a. a central processing unit,
- b. a data storage device connected to said central processing unit,
- c. an operating system including a graphical user interface,
- d. a first menu consisting of menu categories, said menu categories consisting of menu items, said first menu stored on said data storage device and displayable in a window of said graphical user interface in a hierarchical tree format,
- e. a modifier menu stored on said data storage device and displayable in a window of said graphical user interface,
- f. a sub-modifier menu stored on said data storage device and displayable in a window of said graphical user interface, and