

(12) **United States Patent**
Katzenberg et al.

(10) **Patent No.:** **US 6,218,930 B1**
(45) **Date of Patent:** **Apr. 17, 2001**

(54) **APPARATUS AND METHOD FOR REMOTELY POWERING ACCESS EQUIPMENT OVER A 10/100 SWITCHED ETHERNET NETWORK**

(75) Inventors: **Boris Katzenberg**, Trumbull; **Joseph A. Deptula**, Watertown, both of CT (US)

(73) Assignee: **Merlot Communications**, Bethel, CT (US)

(*) Notice: Subject to any disclaimer, the term of this patent is extended or adjusted under 35 U.S.C. 154(b) by 0 days.

(21) Appl. No.: **09/520,350**

(22) Filed: **Mar. 7, 2000**

Related U.S. Application Data

(60) Provisional application No. 60/123,688, filed on Mar. 10, 1999.

(51) **Int. Cl.⁷** **M04M 11/04**

(52) **U.S. Cl.** **340/310.01**; 340/310.02; 340/310.06; 340/310.07; 379/386; 379/400; 379/32

(58) **Field of Search** 340/310.01, 310.07, 340/825.16, 310.02, 310.06; 379/386, 400, 32

(56) **References Cited**

U.S. PATENT DOCUMENTS

5,144,544	9/1992	Jenneve et al. .	
5,289,359 *	2/1994	Ziermann	363/21
5,406,260 *	4/1995	Cummings et al.	340/568
5,461,671 *	10/1995	Sakuragi et al.	379/400
5,483,574 *	1/1996	Yuyama	379/32
5,608,792 *	3/1997	Laidler	379/386

* cited by examiner

Primary Examiner—Jeffery A. Hofsass

Assistant Examiner—Tai T. Nguyen

(74) *Attorney, Agent, or Firm*—William C. Crutcher

(57) **ABSTRACT**

Apparatus for remotely powering access equipment over a 10/100 switched Ethernet network comprises an Ethernet switch card with a phantom power supply for remote access equipment and added circuitry for automatic detection of remote equipment being connected to the network; determining whether the remote equipment is capable of accepting remote power in a non-intrusive manner; delivering the phantom power to the remote equipment over the same wire pairs that deliver the data signals, and automatically detecting if the remote equipment is removed from the network.

9 Claims, 3 Drawing Sheets

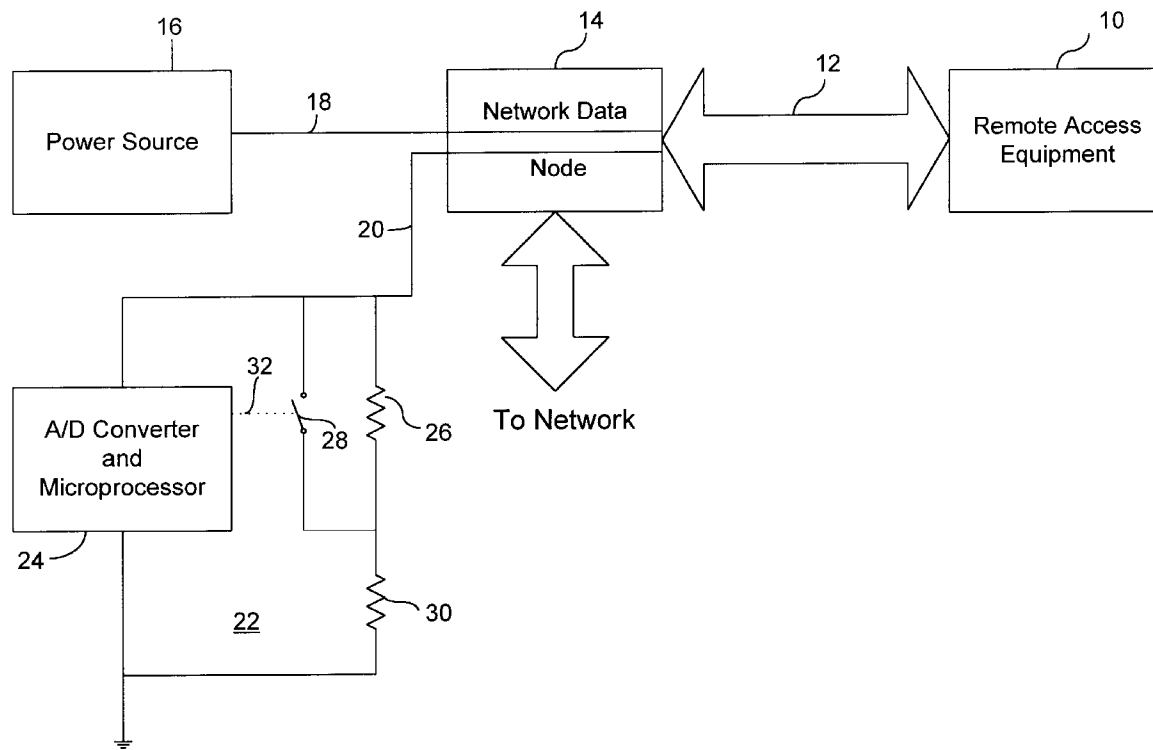

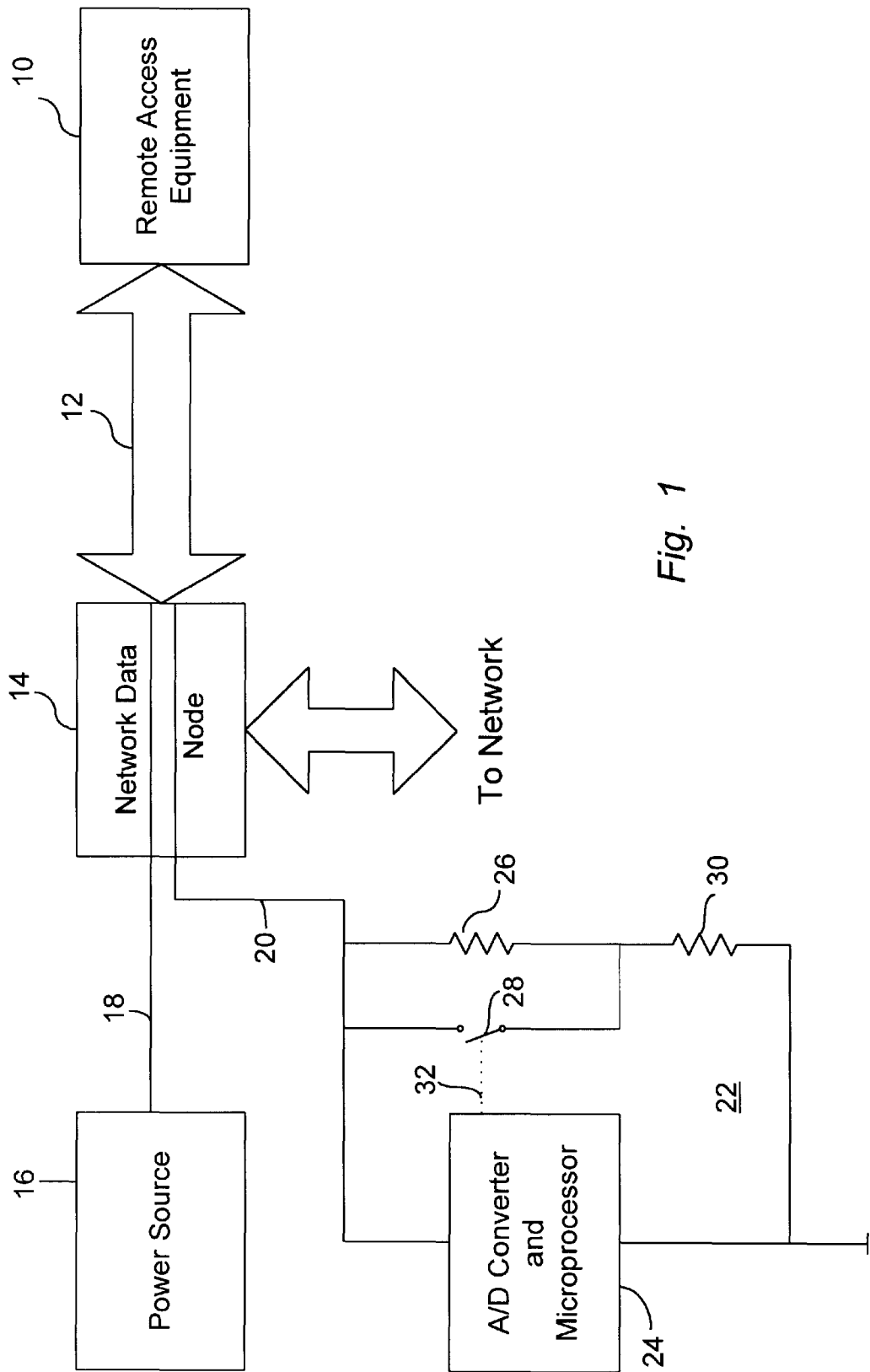

Fig. 1

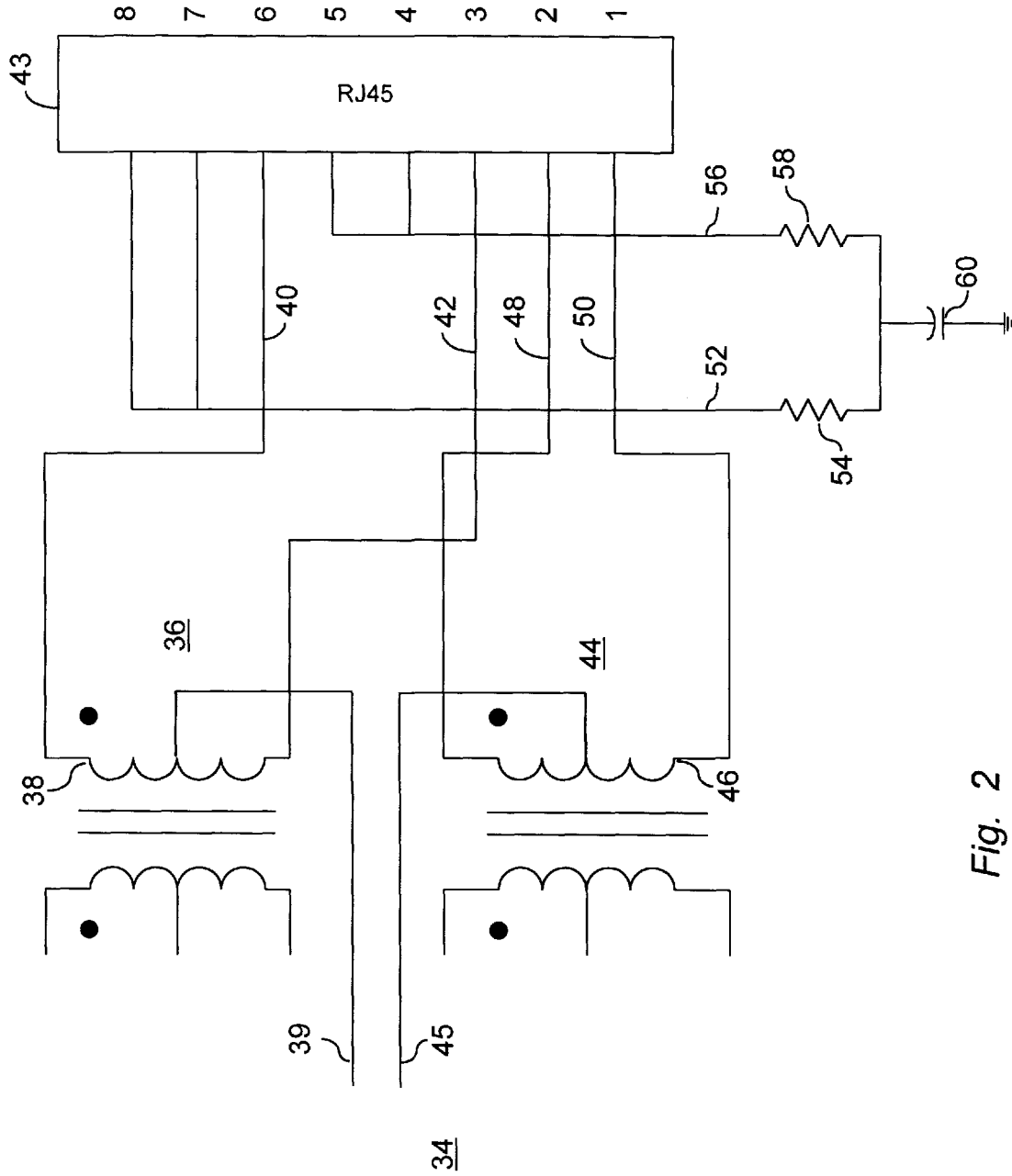

Fig. 2

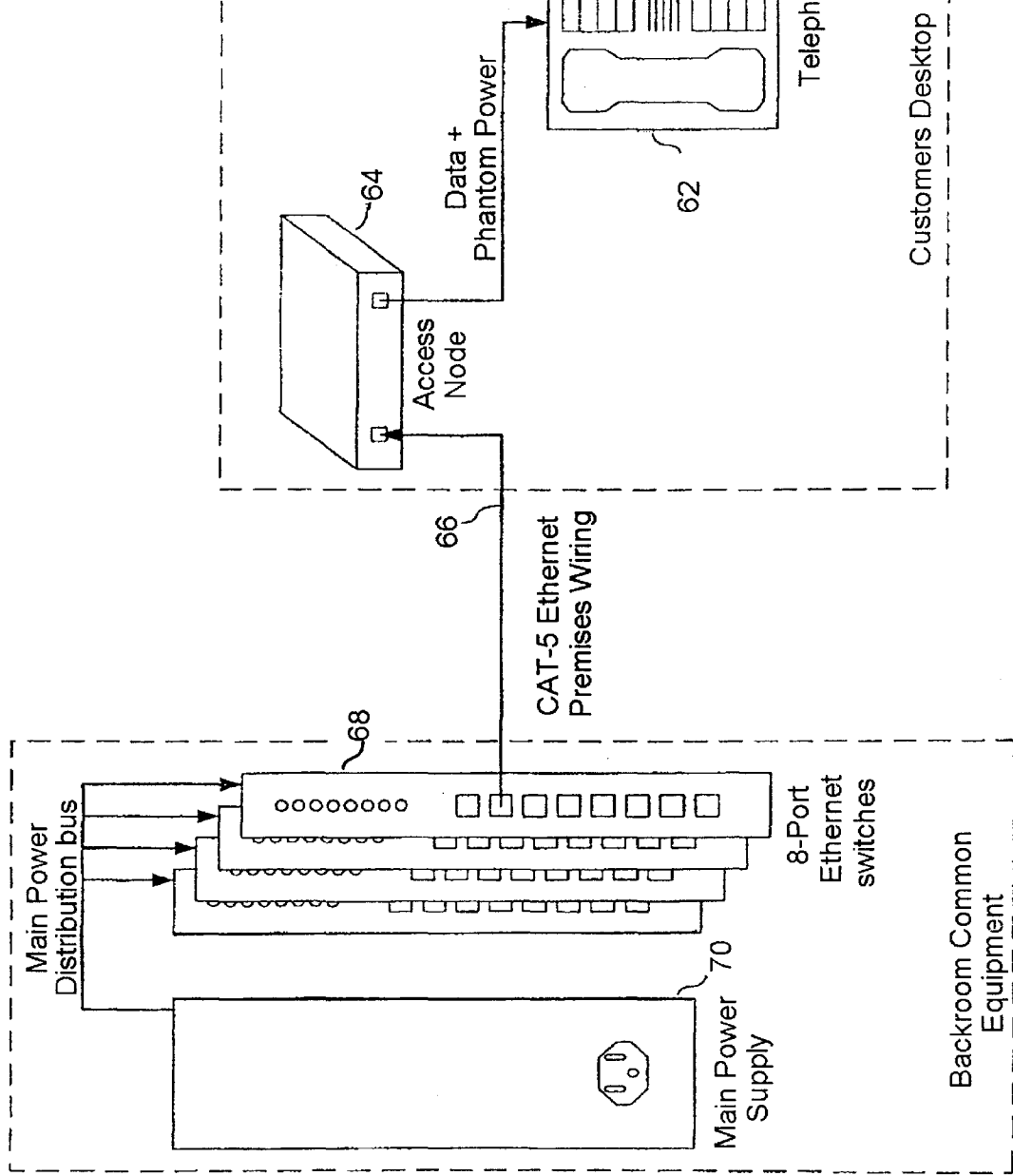

Fig. 3

**APPARATUS AND METHOD FOR
REMOTELY POWERING ACCESS
EQUIPMENT OVER A 10/100 SWITCHED
ETHERNET NETWORK**

**CROSS REFERENCE TO RELATED
APPLICATIONS**

This application claims the benefits of prior filed, application Ser. No. 60/123,688 filed Mar. 10, 1999.

FIELD OF THE INVENTION

This invention broadly relates to the powering of 10/100 Ethernet compatible equipment. The invention more particularly relates to apparatus and methods for automatically determining if remote equipment is capable of remote power feed and if it is determined that the remote equipment is able to accept power remotely then to provide power in a reliable non-intrusive way.

BACKGROUND OF THE INVENTION

A variety of telecommunications equipment is remotely powered today. Telephones and Network Repeater devices are examples of remotely powered equipment. Obviously there are many advantages to remotely powering equipment, however this technique has not migrated to data communications equipment for several reasons. Data communications equipment has traditionally required high power levels to operate which has made it prohibitive to implement. The widely distributed nature as well as the use of shared media used in data networks has also made remote power impractical.

The desire to add remotely powered devices to a data network is being pushed by the convergence of voice and data technologies. The advent of IP Telephony, Voice over IP and Voice over Packet technologies has brought traditional telephony requirements into the data environment. It is not desirable to have a phone powered by a local wall transformer. It is desirable to have a centrally powered system that can be protected during a power outage.

It is therefore an object of the invention to provide methods and apparatus for reliably determining if a remote piece of equipment is capable of accepting remote power.

It is another object of this invention to provide methods and apparatus for delivering remote power to remote equipment over 10/100 switched Ethernet segments and maintain compliance with IEEE 802.3 standards.

SUMMARY OF THE INVENTION

In accord with the objects of the invention an apparatus for remotely powering access equipment over a 10/100 switched Ethernet network comprises: automatic detection of remote equipment being connected to the network; determining whether the remote equipment is capable of accepting remote power in a non-intrusive manner; delivering the power to remote equipment over the same wire pairs that deliver the data signals; automatic detection of remote equipment being removed from the network.

The complete apparatus comprises a data node adapted for data switching, an access device adapted for data transmission, at least one data signaling pair connected between the data node and the access device and arranged to transmit data therebetween, a main power source connected to supply power to the data node, a secondary power source arranged to supply power from the data node via the data signaling pair to the access device, sensing means for

delivering a low level current from said main power source to the access device over the data signaling pair and sensing a resulting voltage level thereon, and control means responsive to said voltage level and adapted to control power supplied by the secondary power source to said access device in response to a preselected condition of the voltage level.

The method includes the steps of delivering a low level current from the main power source to the access device over the data signaling pair, sensing a voltage level on the data signaling pair in response to the low level current, and controlling power supplied by the secondary power source to the access device in response to a preselected condition of the voltage level.

DRAWINGS

The invention will be more clearly understood by reference to the following description, taken in connection with the accompanying drawings, in which:

FIG. 1 is a simplified schematic diagram of the remote power automatic detection system of the present invention, shown in conjunction with a single unit of remote access equipment connected as part of an Ethernet local area network,

FIG. 2 is a simplified schematic drawing of a power feed configuration for supplying power to the remote access equipment on the local area network, and

FIG. 3 is a simplified physical layout of a portion of a switched Ethernet network segment showing a telephone device powered through the network data carrying medium.

**DESCRIPTION OF THE PREFERRED
EMBODIMENT**

Referring now to FIG. 1 of the drawing, a remote access device **10** which is compatible with 10/100 Ethernet requirements is connected through a data communications network interface adapter to a high data rate network cable **12**. Remote access device **10** requires power to carry out its operation and includes an internal dc-dc switching supply which, in the absence of the present invention, would be supplied by an ac transformer adapter plugged in to the local 110 volt supply. Cable **12** is preferably Category **5** wiring such as 100BaseX suitable for 100 Mb/s data communications over a switched Ethernet network, and is connected to a port in a network data node **14**, such as a switch or hub. Ethernet frames containing data are transmitted over cable **12** between node **14** and device **10**, and from node **14** to and from the network in accordance with selected protocols in a conventional manner known in the art.

In accordance with the present invention, a power source **16**, which may be the same as the conventional main power supply used to power the node **14**, is connected to cable **12** via lines **18** to supply a power level sensing potential to the remote access equipment **10** over one of the cable conductors. A return path from remote access equipment **10** is connected through a lead **20** to an automatic remote power detector, shown generally as **22**. Detector **22** includes an A/D converter and microprocessor control unit **24**, operating a detection circuit consisting of a resistor **26**, with shunting switch **28**, both connected in parallel to a resistor **30**, providing a path to ground. Switch **28** is actually an internal software controlled switch depicted diagrammatically as actuated by operator **32**.

Automatic detection of remote equipment being connected to the network is accomplished by delivering a low

Explore Litigation Insights

Docket Alarm provides insights to develop a more informed litigation strategy and the peace of mind of knowing you're on top of things.

Real-Time Litigation Alerts



Keep your litigation team up-to-date with **real-time alerts** and advanced team management tools built for the enterprise, all while greatly reducing PACER spend.

Our comprehensive service means we can handle Federal, State, and Administrative courts across the country.

Advanced Docket Research



With over 230 million records, Docket Alarm's cloud-native docket research platform finds what other services can't. Coverage includes Federal, State, plus PTAB, TTAB, ITC and NLRB decisions, all in one place.

Identify arguments that have been successful in the past with full text, pinpoint searching. Link to case law cited within any court document via Fastcase.

Analytics At Your Fingertips



Learn what happened the last time a particular judge, opposing counsel or company faced cases similar to yours.

Advanced out-of-the-box PTAB and TTAB analytics are always at your fingertips.

API

Docket Alarm offers a powerful API (application programming interface) to developers that want to integrate case filings into their apps.

LAW FIRMS

Build custom dashboards for your attorneys and clients with live data direct from the court.

Automate many repetitive legal tasks like conflict checks, document management, and marketing.

FINANCIAL INSTITUTIONS

Litigation and bankruptcy checks for companies and debtors.

E-DISCOVERY AND LEGAL VENDORS

Sync your system to PACER to automate legal marketing.