

Under the Paperwork Reduction Act of 1995, no persons are required to respond to a collection of information unless it displays a valid OMB control number.

U.S. Patent and Trademark Office; U.S. DEPARTMENT OF COMMERCE

| | | |
|--|------------------------|---------------------------------|
| PATENT - POWER OF ATTORNEY OR REVOCATION OF POWER OF ATTORNEY WITH A NEW POWER OF ATTORNEY AND CHANGE OF CORRESPONDENCE ADDRESS | Patent Number | 7334720 |
| | Issue Date | February 26, 2008 |
| | First Named Inventor | Hulst; Hermenard |
| | Title | Data Storage and Access Systems |
| | Attorney Docket Number | |

I hereby revoke all previous powers of attorney given in the above-identified patent.

A Power of Attorney is submitted herewith.

OR

I hereby appoint Practitioner(s) associated with the following Customer Number as my/our attorney(s) or agent(s) with respect to the patent identified above, and to transact all business in the United States Patent and Trademark Office connected therewith: 42624

OR

I hereby appoint Practitioner(s) named below as my/our attorney(s) or agent(s) with respect to the patent identified above, and to transact all business in the United States Patent and Trademark Office connected therewith:

| Practitioner(s) Name | Registration Number |
|----------------------|---------------------|
| | |
| | |
| | |
| | |

Please recognize or change the correspondence address for the above-identified patent to:

The address associated with the above-mentioned Customer Number.

OR

The address associated with Customer Number:

OR

Firm or Individual Name

Address

City State Zip

Country

Telephone Email

I am the:

Inventor, having ownership of the patent.

OR

Patent owner.
Statement under 37 CFR 3.73(b) (Form PTO/SB/96) submitted herewith or filed on _____

SIGNATURE of Inventor or Patent Owner

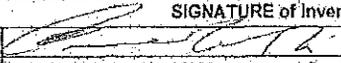
| | | | |
|-------------------|---|-----------|---------------|
| Signature |  | Date | April 7, 2014 |
| Name | Leon Unterhalter, for LU Management Services Inc. as | Telephone | |
| Title and Company | Manager of Smartflash LLC, President | | |

NOTE: Signatures of all the inventors or patent owners of the entire interest or their representative(s) are required. Submit multiple forms if more than one signature is required, see below.

Total of _____ forms are submitted.

This collection of information is required by 37 CFR 1.31, 1.32 and 1.33. The information is required to obtain or retain a benefit by the public which is to file (and by the USPTO to process) an application. Confidentiality is governed by 35 U.S.C. 122 and 37 CFR 1.11 and 1.14. This collection is estimated to take 3 minutes to complete, including gathering, preparing, and submitting the completed application form to the USPTO. Time will vary depending upon the individual case. Any comments on the amount of time you require to complete this form and/or suggestions for reducing this burden, should be sent to the Chief Information Officer, U.S. Patent and Trademark Office, U.S. Department of Commerce, P.O. Box 1450, Alexandria, VA 22313-1450. DO NOT SEND FEES OR COMPLETED FORMS TO THIS ADDRESS. SEND TO: Commissioner for Patents, P.O. Box 1450, Alexandria, VA 22313-1450.

If you need assistance in completing the form, call 1-800-PTO-9199 and select option 2.

STATEMENT UNDER 37 CFR 3.73(b)Applicant/Patent Owner: Smartflash LLCApplication No./Patent No.: 7334720Filed/Issue Date: February 26, 2008Titled: Data Storage and Access SystemsSmartflash LLC, a Corporation

(Name of Assignee)

(Type of Assignee, e.g., corporation, partnership, university, government agency, etc.)

states that it is:

1. the assignee of the entire right, title, and interest in;
2. an assignee of less than the entire right, title, and interest in (The extent (by percentage) of its ownership interest is _____ %); or
3. the assignee of an undivided interest in the entirety of (a complete assignment from one of the joint inventors was made) the patent application/patent identified above, by virtue of either:

A. An assignment from the inventor(s) of the patent application/patent identified above. The assignment was recorded in the United States Patent and Trademark Office at Reel _____, Frame _____, or for which a copy therefore is attached.

OR

B. A chain of title from the inventor(s), of the patent application/patent identified above, to the current assignee as follows:

1. From: Herman-ard Hulst To: Smartflash Limited

The document was recorded in the United States Patent and Trademark Office at Reel 013583, Frame 0554, or for which a copy thereof is attached.

2. From: Smartflash Limited To: Patrick Racz

The document was recorded in the United States Patent and Trademark Office at Reel 024710, Frame 0790, or for which a copy thereof is attached.

3. From: Patrick Racz To: Smartflash Technologies Limited

The document was recorded in the United States Patent and Trademark Office at Reel 024710, Frame 0796, or for which a copy thereof is attached.

Additional documents in the chain of title are listed on a supplemental sheet(s).

As required by 37 CFR 3.73(b)(1)(i), the documentary evidence of the chain of title from the original owner to the assignee was, or concurrently is being, submitted for recordation pursuant to 37 CFR 3.11.

[NOTE: A separate copy (*i.e.*, a true copy of the original assignment document(s)) must be submitted to Assignment Division in accordance with 37 CFR Part 3, to record the assignment in the records of the USPTO. See MPEP 302.08]

The undersigned (whose title is supplied below) is authorized to act on behalf of the assignee.

/ Michael R. Casey /

Signature

4-18-2014

Date

Michael R. Casey

Printed or Typed Name

Attorney of Record

Title

This collection of information is required by 37 CFR 3.73(b). The information is required to obtain or retain a benefit by the public which is to file (and by the USPTO to process) an application. Confidentiality is governed by 35 U.S.C. 122 and 37 CFR 1.11 and 1.14. This collection is estimated to take 12 minutes to complete, including gathering, preparing, and submitting the completed application form to the USPTO. Time will vary depending upon the individual case. Any comments on the amount of time you require to complete this form and/or suggestions for reducing this burden, should be sent to the Chief Information Officer, U.S. Patent and Trademark Office, U.S. Department of Commerce, P.O. Box 1450, Alexandria, VA 22313-1450. DO NOT SEND FEES OR COMPLETED FORMS TO THIS ADDRESS. SEND TO: Commissioner for Patents, P.O. Box 1450, Alexandria, VA 22313-1450.

If you need assistance in completing the form, call 1-800-PTO-9199 and select option 2.

Continuation Sheet for Statement under 37 CFR 3.73(b) for U.S. Patent No. 7334720

4. From: Smartflash Technologies Limited To: Smartflash LLC

The document was recorded in the United States Patent and Trademark Office at Reel: 030522 Frame: 0877.

| Electronic Acknowledgement Receipt | |
|---|---------------------------------|
| EFS ID: | 18801478 |
| Application Number: | 11336758 |
| International Application Number: | |
| Confirmation Number: | 3911 |
| Title of Invention: | DATA STORAGE AND ACCESS SYSTEMS |
| First Named Inventor/Applicant Name: | Hermen-ard Hulst |
| Customer Number: | 20350 |
| Filer: | Michael R. Casey |
| Filer Authorized By: | |
| Attorney Docket Number: | 87790-707431 (000100US) |
| Receipt Date: | 18-APR-2014 |
| Filing Date: | 19-JAN-2006 |
| Time Stamp: | 11:55:02 |
| Application Type: | Utility under 35 USC 111(a) |

Payment information:

| Submitted with Payment | | no | | | |
|------------------------|----------------------|-------------|---|------------------|------------------|
| File Listing: | | | | | |
| Document Number | Document Description | File Name | File Size(Bytes)/ Message Digest | Multi Part /.zip | Pages (if appl.) |
| 1 | Power of Attorney | 720_POA.pdf | 172039 <small>0b72b139cd4057e58b69783f6c850e9899c765</small> | no | 1 |
| Warnings: | | | | | |
| Information: | | | | | |

| | | | | | |
|---|--|--------------------------------|---|--------|---|
| 2 | Assignee showing of ownership per 37 CFR 3.73. | 720_patent_AssigneeShowing.pdf | 98076 5b6118f7b499c2eba325dd7c9ad3e3fec3e c14e0 | no | 2 |
| Warnings: | | | | | |
| Information: | | | | | |
| Total Files Size (in bytes): | | | | 270115 | |
| <p>This Acknowledgement Receipt evidences receipt on the noted date by the USPTO of the indicated documents, characterized by the applicant, and including page counts, where applicable. It serves as evidence of receipt similar to a Post Card, as described in MPEP 503.</p> <p><u>New Applications Under 35 U.S.C. 111</u> If a new application is being filed and the application includes the necessary components for a filing date (see 37 CFR 1.53(b)-(d) and MPEP 506), a Filing Receipt (37 CFR 1.54) will be issued in due course and the date shown on this Acknowledgement Receipt will establish the filing date of the application.</p> <p><u>National Stage of an International Application under 35 U.S.C. 371</u> If a timely submission to enter the national stage of an international application is compliant with the conditions of 35 U.S.C. 371 and other applicable requirements a Form PCT/DO/EO/903 indicating acceptance of the application as a national stage submission under 35 U.S.C. 371 will be issued in addition to the Filing Receipt, in due course.</p> <p><u>New International Application Filed with the USPTO as a Receiving Office</u> If a new international application is being filed and the international application includes the necessary components for an international filing date (see PCT Article 11 and MPEP 1810), a Notification of the International Application Number and of the International Filing Date (Form PCT/RO/105) will be issued in due course, subject to prescriptions concerning national security, and the date shown on this Acknowledgement Receipt will establish the international filing date of the application.</p> | | | | | |

AO 120 (Rev. 08/10)

| | |
|---|--|
| TO: Mail Stop 8 Director of the U.S. Patent and Trademark Office P.O. Box 1450 Alexandria, VA 22313-1450 | REPORT ON THE FILING OR DETERMINATION OF AN ACTION REGARDING A PATENT OR TRADEMARK |
|---|--|

In Compliance with 35 U.S.C. § 290 and/or 15 U.S.C. § 1116 you are hereby advised that a court action has been filed in the U.S. District Court Eastern District of Texas Tyler Division on the following
 Trademarks or Patents. (the patent action involves 35 U.S.C. § 292.);

| | | |
|---|-----------------------------|---|
| DOCKET NO. 6:13-cv-447 | DATE FILED 5/29/2013 | U.S. DISTRICT COURT Eastern District of Texas Tyler Division |
| PLAINTIFF Smartflash LLC and Smartflash Technologies Limited | | DEFENDANT Apple Inc., Robot Entertainment, Inc., Kingsisle Entertainment, Inc. and Game Circus LLC |
| PATENT OR TRADEMARK NO. | DATE OF PATENT OR TRADEMARK | HOLDER OF PATENT OR TRADEMARK |
| 1 7,334,720 | 2/26/2008 | Smartflash LLC |
| 2 7,942,317 | 5/17/2011 | Smartflash LLC |
| 3 8,033,458 | 10/11/2011 | Smartflash LLC |
| 4 8,061,598 | 11/22/2011 | Smartflash LLC |
| 5 8,118,221 | 2/21/2012 | Smartflash LLC |

In the above—entitled case, the following patent(s)/ trademark(s) have been included:

| | | | |
|-------------------------|--|-------------------------------|--|
| DATE INCLUDED | INCLUDED BY <input type="checkbox"/> Amendment <input type="checkbox"/> Answer <input type="checkbox"/> Cross Bill <input type="checkbox"/> Other Pleading | | |
| PATENT OR TRADEMARK NO. | DATE OF PATENT OR TRADEMARK | HOLDER OF PATENT OR TRADEMARK | |
| 1 8,336,772 | | | |
| 2 | | | |
| 3 | | | |
| 4 | | | |
| 5 | | | |

In the above—entitled case, the following decision has been rendered or judgement issued:

| |
|--------------------|
| DECISION/JUDGEMENT |
|--------------------|

| | | |
|-------|-------------------|------|
| CLERK | (BY) DEPUTY CLERK | DATE |
|-------|-------------------|------|

Copy 1—Upon initiation of action, mail this copy to Director Copy 3—Upon termination of action, mail this copy to Director
 Copy 2—Upon filing document adding patent(s), mail this copy to Director Copy 4—Case file copy

AO 120 (Rev. 08/10)

| | |
|---|--|
| TO: Mail Stop 8 Director of the U.S. Patent and Trademark Office P.O. Box 1450 Alexandria, VA 22313-1450 | REPORT ON THE FILING OR DETERMINATION OF AN ACTION REGARDING A PATENT OR TRADEMARK |
|---|--|

In Compliance with 35 U.S.C. § 290 and/or 15 U.S.C. § 1116 you are hereby advised that a court action has been filed in the U.S. District Court Eastern District of Texas Tyler Division on the following
 Trademarks or Patents. (the patent action involves 35 U.S.C. § 292.):

| | | |
|---|-----------------------------|---|
| DOCKET NO. 6:13-cv-448 | DATE FILED 5/29/2013 | U.S. DISTRICT COURT Eastern District of Texas Tyler Division |
| PLAINTIFF Smartflash LLC and Smartflash Technologies Limited | | DEFENDANT Samsung Electronics Co., Ltd., Samsung Electronics America, Inc., Samsung Telecommunications America, LLC, HTC Corporation, HTC America, Inc., Exedeia, Inc. and Game Circus LLC |
| PATENT OR TRADEMARK NO. | DATE OF PATENT OR TRADEMARK | HOLDER OF PATENT OR TRADEMARK |
| 1 7,334,720 | 2/26/2008 | Smartflash LLC |
| 2 7,942,317 | 5/17/2011 | Smartflash LLC |
| 3 8,033,458 | 10/11/2011 | Smartflash LLC |
| 4 8,061,598 | 11/22/2011 | Smartflash LLC |
| 5 8,118,221 | 2/21/2012 | Smartflash LLC |

In the above—entitled case, the following patent(s)/ trademark(s) have been included:

| | | |
|-------------------------|---|-------------------------------|
| DATE INCLUDED | INCLUDED BY <input type="checkbox"/> Amendment <input type="checkbox"/> Answer <input type="checkbox"/> Cross Bill <input type="checkbox"/> Other Pleading | |
| PATENT OR TRADEMARK NO. | DATE OF PATENT OR TRADEMARK | HOLDER OF PATENT OR TRADEMARK |
| 1 8,336,772 | | |
| 2 | | |
| 3 | | |
| 4 | | |
| 5 | | |

In the above—entitled case, the following decision has been rendered or judgement issued:

| |
|--------------------|
| DECISION/JUDGEMENT |
|--------------------|

| | | |
|-------|-------------------|------|
| CLERK | (BY) DEPUTY CLERK | DATE |
|-------|-------------------|------|

Copy 1—Upon initiation of action, mail this copy to Director Copy 3—Upon termination of action, mail this copy to Director
 Copy 2—Upon filing document adding patent(s), mail this copy to Director Copy 4—Case file copy

UNITED STATES PATENT AND TRADEMARK OFFICE
CERTIFICATE OF CORRECTION

PATENT NO. : 7,334,720 B2
APPLICATION NO. : 11/336758
DATED : February 26, 2008
INVENTOR(S) : Hermen-ard Hulst and Patrick Sandor Racz

Page 1 of 1

It is certified that error appears in the above-identified patent and that said Letters Patent is hereby corrected as shown below:

On the front of the patent, left column, under the Foreign Application Priority Data heading, the priority data is listed incorrectly.

Please delete "Nov. 25, 1999," and insert -- Oct. 25, 1999 --

Signed and Sealed this

Thirty-first Day of August, 2010

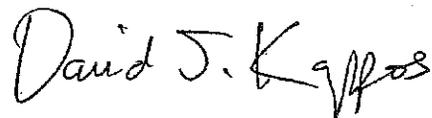

David J. Kappos
Director of the United States Patent and Trademark Office



UNITED STATES PATENT AND TRADEMARK OFFICE

Commissioner for Patents
United States Patent and Trademark Office
P.O. Box 1450
Alexandria, VA 22313-1450
www.uspto.gov

Patent No. : 7334720
Ser. No. : 11/336758
Inventor(s) : HULST, HERMEN-ARD .
Issued : 02/26/2008
Title : DATA STORAGE AND ACCESS SYSTEMS
Docket No. : 080379-000100US

Re: Request for Certificate of Correction

Consideration has been given your request for the issuance of a certificate of correction for the above-identified patent under the provisions of Rule(s) 1.322 and/or 1.323.

In regards to the alleged error(s) on the Title Page Item [75] Inventors, the patent is printed in accordance with the Oath of Declaration filed by the Applicant/Attorney on 1-19-06.

In view of the foregoing, your request, in this matter, is hereby denied.

However, a petition under 37 CFR 1.182 (required fee currently \$130) to correct the order of inventors should be directed to the attention of:

By mail: Mail Stop PETITIONS
Commissioner for Patents
Post Office Box 1450
Alexandria, VA 22313-1450

By hand: Customer Service Window
Mail Stop Petitions
Randolph Building
401 Dulany Street
Alexandria, VA 22314

By fax: (703) 872-9306
ATTN: Office of Petitions

A Certificate of Correction will be issued to correct the remaining error(s) noted in your request.

Omega Lewis
For Mary Diggs
Decisions & Certificates
Of Correction Branch
(703)756-1575 or (703) 756-1814

Jason D. Lohr, Esq.
TOWNSEND AND TOWNSEND AND CREW LLP
Two Embarcadero Center, Eighth Floor
San Francisco, CA 94111-3834
OL

I hereby certify that this correspondence is being filed via
EFS-Web with the United States Patent and Trademark Office
on 07-30-10

PATENT

Attorney Docket No.: 080379-000110US
Client Ref. No.: F/USP81421X Con.

TOWNSEND and TOWNSEND and CREW LLP

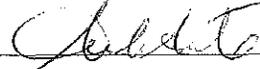
By: 

IN THE UNITED STATES PATENT AND TRADEMARK OFFICE

In re application of:

Hermen-ard Hulst, et al.

Patent No.: 7,334,720

Issued: February 26, 2008

For: DATA STORAGE AND ACCESS
SYSTEMS

Confirmation No.: 3911

Examiner: Steve S. Paik

Technology Center/Art Unit: 3663

REQUEST FOR CERTIFICATE OF
CORRECTION UNDER §1.323

Attn: Certificate of Correction Branch
Commissioner for Patents
P.O. Box 1450
Alexandria, VA 22313-1450

Sir:

Pursuant to 37 CFR 1.323, Applicants submit a Request for Certificate of Correction to correct typographical errors made in the patent. The desired corrections are set forth on the enclosed Form PTO/SB/44.

Inventor Order

Applicant requests a correction to the order of inventors to reflect Patrick Sandor Racz as first inventor.

Reprint of Title Page of Patent

A telephone conversation between my assistant, Anna Marie Arante and Michele Williams of the Certificate of Correction Branch, took place on July 21, 2010. Ms. Williams informed us that the title page of the patent can be reprinted, at no cost, to reflect changes made to the title page of the patent. Therefore, Applicant requests that the Title page (1st page) of the

patent be reprinted to reflect the new order of inventors and that the title is shown as "Racz, et al."

Priority Information

Applicant requests that the foreign application priority data is corrected to reflect the correct priority date. The correct priority date is October 25, 1999. Attached is an excerpt from the UK Patent Office showing the correct filing date of priority application no. 9925227.2 as October 25, 1999, in support of this correction.

Please charge the certificate of correction for applicant's mistake fee of \$100 to Deposit Account No. 20-1430. Please deduct any additional fees from, or credit any overpayment to, the above-noted Deposit Account.

Respectfully submitted,

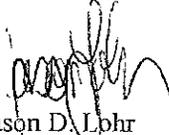

Jason D. Lohr
Reg. No. 48,163

TOWNSEND and TOWNSEND and CREW LLP
Two Embarcadero Center, Eighth Floor
San Francisco, California 94111-3834
Tel. (415) 576-0200
Fax (415) 576-0300
JDL/ama
62785540 v1

**UNITED STATES PATENT AND TRADEMARK OFFICE
CERTIFICATE OF CORRECTION**Page 1 of 1

PATENT NO. : US7,334,720 B2
APPLICATION NO.: 11/336,758
ISSUE DATE : February 26, 2008
INVENTOR(S) : Hermen-ard Hulst, Patrick Sandor Racz

It is certified that an error appears or errors appear in the above-identified patent and that said Letters Patent is hereby corrected as shown below:

On the front of the patent, left column, the inventor's order as listed is incorrect. It should read:
-- (75) Inventors: Patrick Sandor Racz, St. Helier
Hermen-ard Hulst, Amsterdam --

On the front of the patent, left column, under the Foreign Application Priority Data heading, the priority data is listed incorrectly.

Please delete "Nov. 25, 1999," and insert -- Oct. 25, 1999 --

MAILING ADDRESS OF SENDER (Please do not use customer number below):

Jason D. Lohr, Esq.
TOWNSEND AND TOWNSEND AND CREW LLP
Two Embarcadero Center, Eighth Floor
San Francisco, CA 94111-3834

Attorney Docket No: 080379-000110US
62785201 v1



Patents status information

Application No GB9925227.2

Date Lodged
25.10.1999

Title DATA STORAGE RETRIEVAL AND ACCESS SYSTEM

Applicant(s)
Internet Limited

Application terminated on 8th January 2001

***** END *****

© Crown Copyright 2009
Intellectual Property Office is an operating name of the Patent Office

| Electronic Patent Application Fee Transmittal | | | | |
|--|-------------------------------------|----------|--------|----------------------|
| Application Number: | 11336758 | | | |
| Filing Date: | 19-Jan-2006 | | | |
| Title of Invention: | DATA STORAGE AND ACCESS SYSTEMS | | | |
| First Named Inventor/Applicant Name: | Hermen-ard Hulst | | | |
| Filer: | Jason Donald Lohr/Anna Marie Arante | | | |
| Attorney Docket Number: | 080379-000100US | | | |
| Filed as Small Entity | | | | |
| Utility under 35 USC 111(a) Filing Fees | | | | |
| Description | Fee Code | Quantity | Amount | Sub-Total in USD(\$) |
| Basic Filing: | | | | |
| Pages: | | | | |
| Claims: | | | | |
| Miscellaneous-Filing: | | | | |
| Petition: | | | | |
| Patent-Appeals-and-Interference: | | | | |
| Post-Allowance-and-Post-Issuance: | | | | |
| Certificate of correction | 1811 | 1 | 100 | 100 |
| Extension-of-Time: | | | | |

| Description | Fee Code | Quantity | Amount | Sub-Total in USD(\$) |
|--------------------------|----------|----------|--------|----------------------|
| Miscellaneous: | | | | |
| Total in USD (\$) | | | | 100 |

Electronic Acknowledgement Receipt

| | |
|---|-------------------------------------|
| EFS ID: | 8130896 |
| Application Number: | 11336758 |
| International Application Number: | |
| Confirmation Number: | 3911 |
| Title of Invention: | DATA STORAGE AND ACCESS SYSTEMS |
| First Named Inventor/Applicant Name: | Hermen-ard Hulst |
| Customer Number: | 20350 |
| Filer: | Jason Donald Lohr/Anna Marie Arante |
| Filer Authorized By: | Jason Donald Lohr |
| Attorney Docket Number: | 080379-000100US |
| Receipt Date: | 30-JUL-2010 |
| Filing Date: | 19-JAN-2006 |
| Time Stamp: | 19:54:01 |
| Application Type: | Utility under 35 USC 111(a) |

Payment information:

| | |
|--|-----------------|
| Submitted with Payment | yes |
| Payment Type | Deposit Account |
| Payment was successfully received in RAM | \$100 |
| RAM confirmation Number | 5340 |
| Deposit Account | 201430 |
| Authorized User | |
| <p>The Director of the USPTO is hereby authorized to charge indicated fees and credit any overpayment as follows: Charge any Additional Fees required under 37 C.F.R. Section 1.20 (Post Issuance fees)</p> | |

| File Listing: | | | | | |
|---|---------------------------------------|--|---|-------------------------|-------------------------|
| Document Number | Document Description | File Name | File Size(Bytes)/ Message Digest | Multi Part /.zip | Pages (if appl.) |
| 1 | | 2010_07_30_Request_Cert_Correction_080379_000110US.pdf | 104104 d102331906c1611175a94c8f52a1db09e7c0e7b | yes | 4 |
| Multipart Description/PDF files in .zip description | | | | | |
| | Document Description | | Start | | End |
| | Request for Certificate of Correction | | 1 | | 2 |
| | Request for Certificate of Correction | | 3 | | 3 |
| | Miscellaneous Incoming Letter | | 4 | | 4 |
| Warnings: | | | | | |
| Information: | | | | | |
| 2 | Fee Worksheet (PTO-875) | fee-info.pdf | 29795 ee14607c35cb21f91a956da91ca66315268a0c3 | no | 2 |
| Warnings: | | | | | |
| Information: | | | | | |
| Total Files Size (in bytes): | | | | 133899 | |
| <p>This Acknowledgement Receipt evidences receipt on the noted date by the USPTO of the indicated documents, characterized by the applicant, and including page counts, where applicable. It serves as evidence of receipt similar to a Post Card, as described in MPEP 503.</p> <p><u>New Applications Under 35 U.S.C. 111</u> If a new application is being filed and the application includes the necessary components for a filing date (see 37 CFR 1.53(b)-(d) and MPEP 506), a Filing Receipt (37 CFR 1.54) will be issued in due course and the date shown on this Acknowledgement Receipt will establish the filing date of the application.</p> <p><u>National Stage of an International Application under 35 U.S.C. 371</u> If a timely submission to enter the national stage of an international application is compliant with the conditions of 35 U.S.C. 371 and other applicable requirements a Form PCT/DO/EO/903 indicating acceptance of the application as a national stage submission under 35 U.S.C. 371 will be issued in addition to the Filing Receipt, in due course.</p> <p><u>New International Application Filed with the USPTO as a Receiving Office</u> If a new international application is being filed and the international application includes the necessary components for an international filing date (see PCT Article 11 and MPEP 1810), a Notification of the International Application Number and of the International Filing Date (Form PCT/RO/105) will be issued in due course, subject to prescriptions concerning national security, and the date shown on this Acknowledgement Receipt will establish the international filing date of the application.</p> | | | | | |



UNITED STATES PATENT AND TRADEMARK OFFICE

UNITED STATES DEPARTMENT OF COMMERCE
United States Patent and Trademark Office
Address: COMMISSIONER FOR PATENTS
P.O. Box 1450
Alexandria, Virginia 22313-1450
www.uspto.gov

| APPLICATION NO. | ISSUE DATE | PATENT NO. | ATTORNEY DOCKET NO. | CONFIRMATION NO. |
|-----------------|------------|------------|---------------------|------------------|
| 11/336,758 | 02/26/2008 | 7334720 | 080379-000100US | 3911 |

20350 7590 02/06/2008
TOWNSEND AND TOWNSEND AND CREW, LLP
TWO EMBARCADERO CENTER
EIGHTH FLOOR
SAN FRANCISCO, CA 94111-3834

ISSUE NOTIFICATION

The projected patent number and issue date are specified above.

Determination of Patent Term Adjustment under 35 U.S.C. 154 (b)
(application filed on or after May 29, 2000)

The Patent Term Adjustment is 0 day(s). Any patent to issue from the above-identified application will include an indication of the adjustment on the front page.

If a Continued Prosecution Application (CPA) was filed in the above-identified application, the filing date that determines Patent Term Adjustment is the filing date of the most recent CPA.

Applicant will be able to obtain more detailed information by accessing the Patent Application Information Retrieval (PAIR) WEB site (<http://pair.uspto.gov>).

Any questions regarding the Patent Term Extension or Adjustment determination should be directed to the Office of Patent Legal Administration at (571)-272-7702. Questions relating to issue and publication fee payments should be directed to the Customer Service Center of the Office of Patent Publication at (571)-272-4200.

APPLICANT(s) (Please see PAIR WEB site <http://pair.uspto.gov> for additional applicants):

Hermen and Hulst, Amsterdam, NETHERLANDS;
Patrick Sandor Racz, St. Heller, UNITED KINGDOM;

PART B - FEE(S) TRANSMITTAL

Complete and send this form, together with applicable fee(s), to: Mail Mail Stop ISSUE FEE
 Commissioner for Patents
 P.O. Box 1450
 Alexandria, Virginia 22313-1450
 or Fax (571)-273-2885

INSTRUCTIONS: This form should be used for transmitting the ISSUE FEE and PUBLICATION FEE (if required). Blocks 1 through 5 should be completed where appropriate. All further correspondence including the Patent, advance orders and notification of maintenance fees will be mailed to the current correspondence address as indicated unless corrected below or directed otherwise in Block 1, by (a) specifying a new correspondence address; and/or (b) indicating a separate "FEE ADDRESS" for maintenance fee notifications.

CURRENT CORRESPONDENCE ADDRESS (Note: Use Block 1 for any change of address)

20350 7590 10/04/2007

TOWNSEND AND TOWNSEND AND CREW, LLP
 TWO EMBARCADERO CENTER
 EIGHTH FLOOR
 SAN FRANCISCO, CA 94111-3834

Note: A certificate of mailing can only be used for domestic mailings of the Fee(s) Transmittal. This certificate cannot be used for any other accompanying papers. Each additional paper, such as an assignment or formal drawing, must have its own certificate of mailing or transmission.

Certificate of Mailing or Transmission

I hereby certify that this Fee(s) Transmittal is being deposited with the United States Postal Service with sufficient postage for first class mail in an envelope addressed to the Mail Stop ISSUE FEE address above, or being facsimile transmitted to the USPTO (571) 273-2885, on the date indicated below.

| | |
|--------------------|--------------------|
| Sherri Hale | (Depositor's name) |
| <i>Sherri Hale</i> | (Signature) |
| January 2, 2008 | (Date) |

| APPLICATION NO. | FILING DATE | FIRST NAMED INVENTOR | ATTORNEY DOCKET NO. | CONFIRMATION NO. |
|-----------------|-------------|----------------------|---------------------|------------------|
| 11/336,758 | 01/19/2006 | Hermen-ard Hulst | 080379-000100US | 3911 |

TITLE OF INVENTION: DATA STORAGE AND ACCESS SYSTEMS

| APPLN. TYPE | SMALL ENTITY | ISSUE FEE DUE | PUBLICATION FEE DUE | PREV. PAID ISSUE FEE | TOTAL FEE(S) DUE | DATE DUE |
|----------------|--------------|---------------|---------------------|----------------------|------------------|------------|
| nonprovisional | YES | \$720 | \$300 | \$0 | \$1020 | 01/04/2008 |

| EXAMINER | ART UNIT | CLASS-SUBCLASS |
|---------------|----------|----------------|
| PAIK, STEVE S | 2876 | 235-380000 |

1. Change of correspondence address or indication of "Fee Address" (37 CFR 1.363).
 Change of correspondence address (or Change of Correspondence Address form PTO/SB/122) attached.
 "Fee Address" indication (or "Fee Address" Indication form PTO/SB/47; Rev 03-02 or more recent) attached. Use of a Customer Number is required.

2. For printing on the patent front page, list
 (1) the names of up to 3 registered patent attorneys or agents OR, alternatively,
 (2) the name of a single firm (having as a member a registered attorney or agent) and the names of up to 2 registered patent attorneys or agents. If no name is listed, no name will be printed.

| | |
|---|-----------------------|
| 1 | Townsend and Townsend |
| 2 | and Crew LLP |
| 3 | |

3. ASSIGNEE NAME AND RESIDENCE DATA TO BE PRINTED ON THE PATENT (print or type)
 PLEASE NOTE: Unless an assignee is identified below, no assignee data will appear on the patent. If an assignee is identified below, the document has been filed for recordation as set forth in 37 CFR 3.11. Completion of this form is NOT a substitute for filing an assignment.

(A) NAME OF ASSIGNEE

Smart-Flash Limited

(B) RESIDENCE: (CITY and STATE OR COUNTRY)

East Sussex, Great Britain

Please check the appropriate assignee category or categories (will not be printed on the patent): Individual Corporation or other private group entity Government

4a. The following fee(s) are submitted:
 Issue Fee
 Publication Fee (No small entity discount permitted)
 Advance Order - # of Copies _____

4b. Payment of Fee(s): (Please first reapply any previously paid issue fee shown above)
 A check is enclosed.
 Payment by credit card. Form PTO-2038 is attached.
 The Director is hereby authorized to charge the required fee(s), any deficiency, or credit any overpayment, to Deposit Account Number 20-1430 (enclose an extra copy of this form).

5. Change in Entity Status (from status indicated above)

a. Applicant claims SMALL ENTITY status. See 37 CFR 1.27.

b. Applicant is no longer claiming SMALL ENTITY status. See 37 CFR 1.27(g)(2).

NOTE: The Issue Fee and Publication Fee (if required) will not be accepted from anyone other than the applicant; a registered attorney or agent; or the assignee or other party in interest as shown by the records of the United States Patent and Trademark Office.

Authorized Signature *Jason D. Lohr*
 Typed or printed name Jason D. Lohr

Date January 2, 2008
 Registration No. 48,163

This collection of information is required by 37 CFR 1.311. The information is required to obtain or retain a benefit by the public which is to file (and by the USPTO to process) an application. Confidentiality is governed by 35 U.S.C. 122 and 37 CFR 1.14. This collection is estimated to take 12 minutes to complete, including gathering, preparing, and submitting the completed application form to the USPTO. Time will vary depending upon the individual case. Any comments on the amount of time you require to complete this form and/or suggestions for reducing this burden, should be sent to the Chief Information Officer, U.S. Patent and Trademark Office, U.S. Department of Commerce, P.O. Box 1450, Alexandria, Virginia 22313-1450. DO NOT SEND FEES OR COMPLETED FORMS TO THIS ADDRESS. SEND TO: Commissioner for Patents, P.O. Box 1450, Alexandria, Virginia 22313-1450.

Under the Paperwork Reduction Act of 1995, no persons are required to respond to a collection of information unless it displays a valid OMB control number.

Electronic Patent Application Fee Transmittal

| | | | | |
|---|---------------------------------|-----------------|---------------|-----------------------------|
| Application Number: | 11336758 | | | |
| Filing Date: | 19-Jan-2006 | | | |
| Title of Invention: | DATA STORAGE AND ACCESS SYSTEMS | | | |
| First Named Inventor/Applicant Name: | Hermen-ard Huist | | | |
| Filer: | Jason Donald Lohr/Sherrl Hale | | | |
| Attorney Docket Number: | 080379-000100US | | | |
| Filed as Small Entity | | | | |
| Utility Filing Fees | | | | |
| Description | Fee Code | Quantity | Amount | Sub-Total in USD(\$) |
| Basic Filing: | | | | |
| Pages: | | | | |
| Claims: | | | | |
| Miscellaneous-Filing: | | | | |
| Petition: | | | | |
| Patent-Appeals-and-Interference: | | | | |
| Post-Allowance and-Post-Issuance: | | | | |
| Utility Appl issue fee | 2501 | 1 | 720 | 720 |
| Publ. Fee- early, voluntary, or normal | 1504 | 1 | 300 | 300 |

| Description | Fee Code | Quantity | Amount | Sub-Total in USD(\$) |
|--------------------------|----------|----------|--------|----------------------|
| Extension-of-Time: | | | | |
| Miscellaneous: | | | | |
| Total in USD (\$) | | | | 1020 |

Electronic Acknowledgement Receipt

| | |
|---|---------------------------------|
| EFS ID: | 2662639 |
| Application Number: | 11336758 |
| International Application Number: | |
| Confirmation Number: | 3911 |
| Title of Invention: | DATA STORAGE AND ACCESS SYSTEMS |
| First Named Inventor/Applicant Name: | Hermen-ard Hulst |
| Customer Number: | 20350 |
| Filer: | Jason Donald Lohr/Sherri Hale |
| Filer Authorized By: | Jason Donald Lohr |
| Attorney Docket Number: | 080379-000100US |
| Receipt Date: | 02-JAN-2008 |
| Filing Date: | 19-JAN-2006 |
| Time Stamp: | 18:44:54 |
| Application Type: | Utility under 35 USC 111(a) |

Payment information:

| | |
|--|-----------------|
| Submitted with Payment | yes |
| Payment Type | Deposit Account |
| Payment was successfully received in RAM | \$ 1020 |
| RAM confirmation Number | 2831 |
| Deposit Account | 201430 |
| Authorized User | |

The Director of the USPTO is hereby authorized to charge indicated fees and credit any overpayment as follows:

Charge any Additional Fees required under 37 C.F.R. Section 1.16 (National application filing, search, and examination fees)

Charge any Additional Fees required under 37 C.F.R. Section 1.17 (Patent application and reexamination processing fees)

Charge any Additional Fees required under 37 C.F.R. Section 1.19 (Document supply fees)

Charge any Additional Fees required under 37 C.F.R. Section 1.20 (Post Issuance fees)

Charge any Additional Fees required under 37 C.F.R. Section 1.21 (Miscellaneous fees and charges)

File Listing:

| Document Number | Document Description | File Name | File Size(Bytes) /Message Digest | Multi Part /.zip | Pages (if appl.) |
|-----------------|-----------------------------|-------------------------------------|--|------------------|------------------|
| 1 | Issue Fee Payment (PTO-85B) | 080379_000100US_IssueFeePayment.pdf | 99475 <small>3a9bd5d17a0713b50fecd8e57b9a23b1157b8a</small> | no | 1 |

Warnings:

Information:

| | | | | | |
|---|------------------------|--------------|---|----|---|
| 2 | Fee Worksheet (PTO-06) | fee-info.pdf | 8276 <small>6dcd0945cf71e484f9b4d056ae61db789a9a48b6</small> | no | 2 |
|---|------------------------|--------------|---|----|---|

Warnings:

Information:

Total Files Size (in bytes): 107751

This Acknowledgement Receipt evidences receipt on the noted date by the USPTO of the indicated documents, characterized by the applicant, and including page counts, where applicable. It serves as evidence of receipt similar to a Post Card, as described in MPEP 503.

New Applications Under 35 U.S.C. 111

If a new application is being filed and the application includes the necessary components for a filing date (see 37 CFR 1.53(b)-(d) and MPEP 506), a Filing Receipt (37 CFR 1.54) will be issued in due course and the date shown on this Acknowledgement Receipt will establish the filing date of the application.

National Stage of an International Application under 35 U.S.C. 371

If a timely submission to enter the national stage of an international application is compliant with the conditions of 35 U.S.C. 371 and other applicable requirements a Form PCT/DO/EO/903 indicating acceptance of the application as a national stage submission under 35 U.S.C. 371 will be issued in addition to the Filing Receipt, in due course.

New International Application Filed with the USPTO as a Receiving Office

If a new international application is being filed and the international application includes the necessary components for an international filing date (see PCT Article 11 and MPEP 1810), a Notification of the International Application Number and of the International Filing Date (Form PCT/RO/105) will be issued in due course, subject to prescriptions concerning national security, and the date shown on this Acknowledgement Receipt will establish the international filing date of the application.

1/19/06

PTO/SB/02A (08-03)

| | | | |
|---|------------------------|----------------------|----------------------|
| Substitute for form 1449A/PTO | | Complete if Known | |
| INFORMATION DISCLOSURE STATEMENT BY APPLICANT (use as many sheets as necessary) | | Application Number | 48444-748 11/336,758 |
| | | Filing Date | September 17, 2002 |
| | | First Named Inventor | Hulst, Herman-Ard |
| | | Art Unit | 2876 |
| | | Examiner Name | Paik, Steve S. |
| Sheet 1 of 2 | Attorney Docket Number | 080379-00010045 | |

AE
11-28-07

| U.S. PATENT DOCUMENTS* | | | | | |
|------------------------|-----------------------|---|--------------------------------|---|---|
| Examiner Initials* | Cite No. ¹ | Document Number Number Kind Code ² (if known) | Publication Date MM-DD-YYYY | Name of Patentee or Applicant of Cited Document | Pages, Columns, Lines, Where Relevant Passages or Relevant Figures Appear |
| SSP | AA | US 5,228,145 | 07/08/1993 | Moranaga et al. | |
| | AB | US 5,367,150 | 11/22/1994 | Kita et al. | |
| | AC | US 5,457,746 | 10/10/1995 | Dolphin | |
| | AD | US 5,588,146 | 12/24/1996 | Leroux | |
| | AE | US 5,677,953 | 10/14/1997 | Dolphin | |
| | AF | US 5,703,851 | 12/30/1997 | Dolphin | |
| | AG | US 5,754,654 | 05/19/1998 | Hiroya et al. | |
| | AH | US 5,794,202 | 08/11/1998 | Kim | |
| | AJ | US 5,809,241 | 08/15/1998 | Hanel et al. | |
| | AJ | US 5,847,372 | 12/08/1998 | Kreit | |
| | AK | US 5,889,660 | 03/30/1999 | Eller et al. | |
| | (AL) | US 5,801,330 | 05-24/1999 | Sun et al. | |
| | AM | US 5,910,213 | 08/26/1999 | Bernard et al. | |
| | AN | US 5,923,884 | 07/13/1999 | Peyret et al. | |
| | AO | US 6,012,634 | 01/11/2000 | Brogan et al. | |
| | AP | US 6,078,917 | 08/20/2000 | Paufsen et al. | |
| | AQ | US 6,118,945 | 09/19/2000 | Muller et al. | |
| | AR | US-6,202,058 | 03/13/2001 | Nutall | |
| | AS | US-6,385,731 | 05/07/2002 | Ananda | |
| | AT | US 6,424,975 | 07/23/2002 | Walter et al. | |
| | AU | US 6,442,570 | 08/27/2002 | Wu | |
| | AV | US 6,473,820 | 10/28/2002 | Dahman et al. | |
| | AW | US 6,510,238 | 01/21/2003 | Crane et al. | |
| | AX | US-6,553,413 | 04/22/2003 | Leighton et al. | |
| SSP | AY | US-6,574,643 | 06/03/2003 | Walter et al. | |

| FOREIGN PATENT DOCUMENTS | | | | | | | | |
|--------------------------|-----------------------|---------------------------|---------------------|-----------------------------------|--------------------------------|---|---|--------------------------|
| Examiner Initials* | Cite No. ¹ | Foreign Patent Document | | | Publication Date MM-DD-YYYY | Name of Patentee or Applicant of Cited Document | Pages, Columns, Lines, Where Relevant Passages or Relevant Figures Appear | T ² |
| | | Country Code ³ | Number ⁴ | Kind Code ⁵ (if known) | | | | |
| SSP | AZ | WO | 98/19237 | | 05/07/1998 | | | <input type="checkbox"/> |
| | BA | WO | 98/33343 | | 07/30/1998 | | | <input type="checkbox"/> |
| | BB | WO | 98/37526 | | 08/27/1998 | | | <input type="checkbox"/> |
| | BC | EP | 0195098 | | 10/03/1990 | | | <input type="checkbox"/> |
| | BD | EP | 0713198 | | 05/22/1998 | | | <input type="checkbox"/> |
| | BE | EP | 0823694 | | 02/11/1998 | | | <input type="checkbox"/> |
| | BF | EP | 0542298 | | 04/22/1998 | | | <input type="checkbox"/> |
| | BG | EP | 0843449 | | 05/07/1998 | | | <input type="checkbox"/> |
| SSP | BH | EP | 0914001 | | 05/06/1999 | | | <input type="checkbox"/> |

| | | | |
|--------------------|---------------|-----------------|------------|
| Examiner Signature | /Steven Paik/ | Date Considered | 08/22/2006 |
|--------------------|---------------|-----------------|------------|

*EXAMINER: Initial if reference considered, whether or not citation is in conformance with MPEP 609. Draw line through citation if not in conformance and not considered. Include copy of this form with next communication to applicant. ¹ Applicant's unique citation designation number (optional). ² Kind Codes of U.S. Patent Documents at www.uspto.gov or MPEP 601.04. ³ Enter Office that issued the document, by the two-letter code (WIPO Standard ST.3). ⁴ For Japanese patent documents, the indication of the year of the reign of the Emperor must precede the serial number of the patent document. ⁵ Kind of document by the appropriate symbols as indicated on the document under WIPO Standard ST. 18 if possible. ⁶ Applicant is to place a check mark here if English language Translation is attached.
60113553 v1



UNITED STATES PATENT AND TRADEMARK OFFICE

UNITED STATES DEPARTMENT OF COMMERCE
United States Patent and Trademark Office
Address: COMMISSIONER FOR PATENTS
P.O. Box 1450
Alexandria, Virginia 22313-1450
www.uspto.gov

NOTICE OF ALLOWANCE AND FEE(S) DUE

20350 7590 10/04/2007
TOWNSEND AND TOWNSEND AND CREW, LLP
TWO EMBARCADERO CENTER
EIGHTH FLOOR
SAN FRANCISCO, CA 94111-3834

EXAMINER

PAIK, STEVE S

ART UNIT PAPER NUMBER

2876

DATE MAILED: 10/04/2007

Table with 5 columns: APPLICATION NO., FILING DATE, FIRST NAMED INVENTOR, ATTORNEY DOCKET NO., CONFIRMATION NO.
11/336,758 01/19/2006 Hermen-ard Huist 080379-000100US 3911

TITLE OF INVENTION: DATA STORAGE AND ACCESS SYSTEMS

Table with 7 columns: APPLN. TYPE, SMALL ENTITY, ISSUE FEE DUE, PUBLICATION FEE DUE, PREV. PAID ISSUE FEE, TOTAL FEE(S) DUE, DATE DUE
nonprovisional YES \$720 \$300 \$0 \$1020 01/04/2008

THE APPLICATION IDENTIFIED ABOVE HAS BEEN EXAMINED AND IS ALLOWED FOR ISSUANCE AS A PATENT. PROSECUTION ON THE MERITS IS CLOSED. THIS NOTICE OF ALLOWANCE IS NOT A GRANT OF PATENT RIGHTS. THIS APPLICATION IS SUBJECT TO WITHDRAWAL FROM ISSUE AT THE INITIATIVE OF THE OFFICE OR UPON PETITION BY THE APPLICANT. SEE 37 CFR 1.313 AND MPEP 1308.

THE ISSUE FEE AND PUBLICATION FEE (IF REQUIRED) MUST BE PAID WITHIN THREE MONTHS FROM THE MAILING DATE OF THIS NOTICE OR THIS APPLICATION SHALL BE REGARDED AS ABANDONED. THIS STATUTORY PERIOD CANNOT BE EXTENDED. SEE 35 U.S.C. 151. THE ISSUE FEE DUE INDICATED ABOVE DOES NOT REFLECT A CREDIT FOR ANY PREVIOUSLY PAID ISSUE FEE IN THIS APPLICATION. IF AN ISSUE FEE HAS PREVIOUSLY BEEN PAID IN THIS APPLICATION (AS SHOWN ABOVE), THE RETURN OF PART B OF THIS FORM WILL BE CONSIDERED A REQUEST TO REAPPLY THE PREVIOUSLY PAID ISSUE FEE TOWARD THE ISSUE FEE NOW DUE.

HOW TO REPLY TO THIS NOTICE:

I. Review the SMALL ENTITY status shown above.

If the SMALL ENTITY is shown as YES, verify your current SMALL ENTITY status:

A. If the status is the same, pay the TOTAL FEE(S) DUE shown above.

B. If the status above is to be removed, check box 5b on Part B - Fee(s) Transmittal and pay the PUBLICATION FEE (if required) and twice the amount of the ISSUE FEE shown above, or

If the SMALL ENTITY is shown as NO:

A. Pay TOTAL FEE(S) DUE shown above, or

B. If applicant claimed SMALL ENTITY status before, or is now claiming SMALL ENTITY status, check box 5a on Part B - Fee(s) Transmittal and pay the PUBLICATION FEE (if required) and 1/2 the ISSUE FEE shown above.

II. PART B - FEE(S) TRANSMITTAL, or its equivalent, must be completed and returned to the United States Patent and Trademark Office (USPTO) with your ISSUE FEE and PUBLICATION FEE (if required). If you are charging the fee(s) to your deposit account, section "4b" of Part B - Fee(s) Transmittal should be completed and an extra copy of the form should be submitted. If an equivalent of Part B is filed, a request to reapply a previously paid issue fee must be clearly made, and delays in processing may occur due to the difficulty in recognizing the paper as an equivalent of Part B.

III. All communications regarding this application must give the application number. Please direct all communications prior to issuance to Mail Stop ISSUE FEE unless advised to the contrary.

IMPORTANT REMINDER: Utility patents issuing on applications filed on or after Dec. 12, 1980 may require payment of maintenance fees. It is patentee's responsibility to ensure timely payment of maintenance fees when due.

PART B - FEE(S) TRANSMITTAL

Complete and send this form, together with applicable fee(s), to: **Mail** Mail Stop ISSUE FEE
Commissioner for Patents
P.O. Box 1450
Alexandria, Virginia 22313-1450
 or **Fax** (571)-273-2885

INSTRUCTIONS: This form should be used for transmitting the ISSUE FEE and PUBLICATION FEE (if required). Blocks 1 through 5 should be completed where appropriate. All further correspondence including the Patent, advance orders and notification of maintenance fees will be mailed to the current correspondence address as indicated unless corrected below or directed otherwise in Block 1, by (a) specifying a new correspondence address; and/or (b) indicating a separate "FEE ADDRESS" for maintenance fee notifications.

CURRENT CORRESPONDENCE ADDRESS (Note: Use Block 1 for any change of address)

20350 7590 10/04/2007
TOWNSEND AND TOWNSEND AND CREW, LLP
TWO EMBARCADERO CENTER
EIGHTH FLOOR
SAN FRANCISCO, CA 94111-3834

Note: A certificate of mailing can only be used for domestic mailings of the Fee(s) Transmittal. This certificate cannot be used for any other accompanying papers. Each additional paper, such as an assignment or formal drawing, must have its own certificate of mailing or transmission.

Certificate of Mailing or Transmission
 I hereby certify that this Fee(s) Transmittal is being deposited with the United States Postal Service with sufficient postage for first class mail in an envelope addressed to the Mail Stop ISSUE FEE address above, or being facsimile transmitted to the USPTO (571) 273-2885, on the date indicated below.

| |
|--------------------|
| (Depositor's name) |
| (Signature) |
| (Date) |

| APPLICATION NO. | FILING DATE | FIRST NAMED INVENTOR | ATTORNEY DOCKET NO. | CONFIRMATION NO. |
|-----------------|-------------|----------------------|---------------------|------------------|
| 11/336,758 | 01/19/2006 | Hermen-ard Hulst | 080379-000100US | 3911 |

TITLE OF INVENTION: DATA STORAGE AND ACCESS SYSTEMS

| APPLN. TYPE | SMALL ENTITY | ISSUE FEE DUE | PUBLICATION FEE DUE | PREV. PAID ISSUE FEE | TOTAL FEE(S) DUE | DATE DUE |
|----------------|--------------|---------------|---------------------|----------------------|------------------|------------|
| nonprovisional | YES | \$720 | \$300 | \$0 | \$1020 | 01/04/2008 |

| EXAMINER | ART UNIT | CLASS-SUBCLASS |
|---------------|----------|----------------|
| PAIK, STEVE S | 2876 | 235-380000 |

1. Change of correspondence address or indication of "Fee Address" (37 CFR 1.363).
 Change of correspondence address (or Change of Correspondence Address form PTO/SB/122) attached.
 "Fee Address" indication (or "Fee Address" Indication form PTO/SB/47; Rev 03-02 or more recent) attached. Use of a Customer Number is required.

2. For printing on the patent front page, list
 (1) the names of up to 3 registered patent attorneys or agents OR, alternatively, 1 _____
 (2) the name of a single firm (having as a member a registered attorney or agent) and the names of up to 2 registered patent attorneys or agents. If no name is listed, no name will be printed. 2 _____
 3 _____

3. ASSIGNEE NAME AND RESIDENCE DATA TO BE PRINTED ON THE PATENT (print or type)
 PLEASE NOTE: Unless an assignee is identified below, no assignee data will appear on the patent. If an assignee is identified below, the document has been filed for recordation as set forth in 37 CFR 3.11. Completion of this form is NOT a substitute for filing an assignment.
 (A) NAME OF ASSIGNEE _____ (B) RESIDENCE: (CITY and STATE OR COUNTRY) _____

Please check the appropriate assignee category or categories (will not be printed on the patent): Individual Corporation or other private group entity Government

4a. The following fee(s) are submitted:
 Issue Fee
 Publication Fee (No small entity discount permitted)
 Advance Order - # of Copies _____

4b. Payment of Fee(s): (Please first reapply any previously paid issue fee shown above)
 A check is enclosed.
 Payment by credit card. Form PTO-2038 is attached.
 The Director is hereby authorized to charge the required fee(s), any deficiency, or credit any overpayment, to Deposit Account Number _____ (enclose an extra copy of this form).

5. Change In Entity Status (from status indicated above)
 a. Applicant claims SMALL ENTITY status. See 37 CFR 1.27. b. Applicant is no longer claiming SMALL ENTITY status. See 37 CFR 1.27(g)(2).

NOTE: The Issue Fee and Publication Fee (if required) will not be accepted from anyone other than the applicant; a registered attorney or agent; or the assignee or other party in interest as shown by the records of the United States Patent and Trademark Office.

Authorized Signature _____ Date _____
 Typed or printed name _____ Registration No. _____

This collection of information is required by 37 CFR 1.311. The information is required to obtain or retain a benefit by the public which is to file (and by the USPTO to process) an application. Confidentiality is governed by 35 U.S.C. 122 and 37 CFR 1.14. This collection is estimated to take 12 minutes to complete, including gathering, preparing, and submitting the completed application form to the USPTO. Time will vary depending upon the individual case. Any comments on the amount of time you require to complete this form and/or suggestions for reducing this burden, should be sent to the Chief Information Officer, U.S. Patent and Trademark Office, U.S. Department of Commerce, P.O. Box 1450, Alexandria, Virginia 22313-1450. DO NOT SEND FEES OR COMPLETED FORMS TO THIS ADDRESS. SEND TO: Commissioner for Patents, P.O. Box 1450, Alexandria, Virginia 22313-1450.

Under the Paperwork Reduction Act of 1995, no persons are required to respond to a collection of information unless it displays a valid OMB control number.



UNITED STATES PATENT AND TRADEMARK OFFICE

UNITED STATES DEPARTMENT OF COMMERCE
United States Patent and Trademark Office
Address: COMMISSIONER FOR PATENTS
P.O. Box 1450
Alexandria, Virginia 22313-1450
www.uspto.gov

Table with 5 columns: APPLICATION NO., FILING DATE, FIRST NAMED INVENTOR, ATTORNEY DOCKET NO., CONFIRMATION NO.

11/336,758 01/19/2006 Hermen-ard Hulst 080379-000100US 3911

20350 7590 10/04/2007

TOWNSEND AND TOWNSEND AND CREW, LLP
TWO EMBARCADERO CENTER
EIGHTH FLOOR
SAN FRANCISCO, CA 94111-3834

Table with 1 column: EXAMINER

PAIK, STEVE S

Table with 2 columns: ART UNIT, PAPER NUMBER

2876

DATE MAILED: 10/04/2007

Determination of Patent Term Adjustment under 35 U.S.C. 154 (b)
(application filed on or after May 29, 2000)

The Patent Term Adjustment to date is 0 day(s). If the issue fee is paid on the date that is three months after the mailing date of this notice and the patent issues on the Tuesday before the date that is 28 weeks (six and a half months) after the mailing date of this notice, the Patent Term Adjustment will be 0 day(s).

If a Continued Prosecution Application (CPA) was filed in the above-identified application, the filing date that determines Patent Term Adjustment is the filing date of the most recent CPA.

Applicant will be able to obtain more detailed information by accessing the Patent Application Information Retrieval (PAIR) WEB site (http://pair.uspto.gov).

Any questions regarding the Patent Term Extension or Adjustment determination should be directed to the Office of Patent Legal Administration at (571)-272-7702. Questions relating to issue and publication fee payments should be directed to the Customer Service Center of the Office of Patent Publication at 1-(888)-786-0101 or (571)-272-4200.

Notice of Allowability

| | | |
|-----------------|--------------|--|
| Application No. | Applicant(s) | |
| 11/336,758 | HULST ET AL. | |
| Examiner | Art Unit | |
| Steven S. Paik | 2876 | |

-- The MAILING DATE of this communication appears on the cover sheet with the correspondence address--
 All claims being allowable, PROSECUTION ON THE MERITS IS (OR REMAINS) CLOSED in this application. If not included herewith (or previously mailed), a Notice of Allowance (PTOL-85) or other appropriate communication will be mailed in due course. **THIS NOTICE OF ALLOWABILITY IS NOT A GRANT OF PATENT RIGHTS.** This application is subject to withdrawal from issue at the initiative of the Office or upon petition by the applicant. See 37 CFR 1.313 and MPEP 1308.

1. This communication is responsive to the Amendment After Final filed September 4, 2007.
2. The allowed claim(s) is/are 22,23 and 35-50.
3. Acknowledgment is made of a claim for foreign priority under 35 U.S.C. § 119(a)-(d) or (f).
 - a) All b) Some* c) None of the:
 1. Certified copies of the priority documents have been received.
 2. Certified copies of the priority documents have been received in Application No. 10/111,716.
 3. Copies of the certified copies of the priority documents have been received in this national stage application from the International Bureau (PCT Rule 17.2(a)).

* Certified copies not received: _____

Applicant has THREE MONTHS FROM THE "MAILING DATE" of this communication to file a reply complying with the requirements noted below. Failure to timely comply will result in ABANDONMENT of this application.
THIS THREE-MONTH PERIOD IS NOT EXTENDABLE.

4. A SUBSTITUTE OATH OR DECLARATION must be submitted. Note the attached EXAMINER'S AMENDMENT or NOTICE OF INFORMAL PATENT APPLICATION (PTO-152) which gives reason(s) why the oath or declaration is deficient.
5. CORRECTED DRAWINGS (as "replacement sheets") must be submitted.
 - (a) including changes required by the Notice of Draftsperson's Patent Drawing Review (PTO-948) attached
 - 1) hereto or 2) to Paper No./Mail Date _____.
 - (b) including changes required by the attached Examiner's Amendment / Comment or in the Office action of Paper No./Mail Date _____.

Identifying indicia such as the application number (see 37 CFR 1.84(c)) should be written on the drawings in the front (not the back) of each sheet. Replacement sheet(s) should be labeled as such in the header according to 37 CFR 1.121(d).
6. DEPOSIT OF and/or INFORMATION about the deposit of BIOLOGICAL MATERIAL must be submitted. Note the attached Examiner's comment regarding REQUIREMENT FOR THE DEPOSIT OF BIOLOGICAL MATERIAL.

Attachment(s)

- | | |
|---|---|
| <ol style="list-style-type: none"> 1. <input type="checkbox"/> Notice of References Cited (PTO-892) 2. <input type="checkbox"/> Notice of Draftsperson's Patent Drawing Review (PTO-948) 3. <input type="checkbox"/> Information Disclosure Statements (PTO/SB/08), Paper No./Mail Date _____ 4. <input type="checkbox"/> Examiner's Comment Regarding Requirement for Deposit of Biological Material | <ol style="list-style-type: none"> 5. <input type="checkbox"/> Notice of Informal Patent Application 6. <input checked="" type="checkbox"/> Interview Summary (PTO-413), Paper No./Mail Date <u>herewith.</u> 7. <input checked="" type="checkbox"/> Examiner's Amendment/Comment 8. <input checked="" type="checkbox"/> Examiner's Statement of Reasons for Allowance 9. <input type="checkbox"/> Other _____ |
|---|---|

DETAILED ACTION

Response to Amendment

1. Receipt is acknowledged of the Amendment filed September 4, 2007.

EXAMINER'S AMENDMENT

2. An examiner's amendment to the record appears below. Should the changes and/or additions be unacceptable to applicant, an amendment may be filed as provided by 37 CFR 1.312. To ensure consideration of such an amendment, it MUST be submitted no later than the payment of the issue fee.

Authorization for this examiner's amendment was given in a telephone interview with Mr. Jason Lohr on September 18, 2007.

The application has been amended as follows:

IN THE CLAIMS:

23. (Currently Amended). A method as claimed in claim 22 wherein said parameter memory further stores payment data and further comprising selecting ~~a said use rule~~ one of said use rules dependent upon said payment data.

Allowable Subject Matter

3. Claims 22, 23, and 35-50 are allowed.

The following is an examiner's statement of reasons for allowance: none of the cited prior art of the record discloses, teaches, or fairly suggests claimed method and apparatus for controlling access to content data on a data carrier where the data carrier comprising non-volatile data memory storing content memory and non-volatile parameter memory storing use status and use rules. The prior art is also silent about the step of evaluating the use status data using the use

Art Unit: 2876

rules to determine whether access to the at least one requested content item stored in the content memory is permitted and displaying to the user whether access is permitted for each of the at least one requested content item stored in the data memory. One of the cited prior arts, Hiroya, fails to teach the step of writing at least one access rule into the data carrier, particularly where the access rules contain conditions that are dependent upon an amount of payment associated. After further search and thorough examination of the present application and in view of the Applicant's arguments and amendments, claims 22, 23, and 35-50 are found to be in condition for allowance over the prior art made of record.

Any comments considered necessary by applicant must be submitted no later than the payment of the issue fee and, to avoid processing delays, should preferably accompany the issue fee. Such submissions should be clearly labeled "Comments on Statement of Reasons for Allowance."

Conclusion

Any inquiry concerning this communication or earlier communications from the examiner should be directed to Steven S. Paik whose telephone number is 571-272-2404. The examiner can normally be reached on Monday - Friday 6:30a-3:00p (Maxi-Flex*).

If attempts to reach the examiner by telephone are unsuccessful, the examiner's supervisor, Michael G. Lee can be reached on 571-272-2398. The fax phone number for the organization where this application or proceeding is assigned is 571-273-8300.

Information regarding the status of an application may be obtained from the Patent Application Information Retrieval (PAIR) system. Status information for published applications may be obtained from either Private PAIR or Public PAIR. Status information for unpublished

Application/Control Number: 11/336,758

Page 4

Art Unit: 2876

applications is available through Private PAIR only. For more information about the PAIR system, see <http://pair-direct.uspto.gov>. Should you have questions on access to the Private PAIR system, contact the Electronic Business Center (EBC) at 866-217-9197 (toll-free). If you would like assistance from a USPTO Customer Service Representative or access to the automated information system, call 800-786-9199 (IN USA OR CANADA) or 571-272-1000.

Steven S. Paik
Primary Examiner
(steve.paik@uspto.gov)
Art Unit 2876

ssp

| | | | |
|---|-------------------------------|------------------------------|--|
| Examiner-Initiated Interview Summary | Application No. 11/336,758 | Applicant(s) HULST ET AL. | |
| | Examiner Steven S. Paik | Art Unit 2876 | |

All Participants:

(1) Steven S. Paik.

(2) Jason D. Lohr (Reg. No. 48,163).

Date of Interview: 18 September 2007

Status of Application: _____

(3) _____

(4) _____

Time: 11:30

Type of Interview:

Telephonic

Video Conference

Personal (Copy given to: Applicant Applicant's representative)

Exhibit Shown or Demonstrated: Yes No

If Yes, provide a brief description:

Part I.

Rejection(s) discussed:
n/a

Claims discussed:
23

Prior art documents discussed:
n/a

Part II.

SUBSTANCE OF INTERVIEW DESCRIBING THE GENERAL NATURE OF WHAT WAS DISCUSSED:

The applicant agreed to amend claim 23 by deleting "a said use rule" and inserting -- one of said use rules -- in line 2.

Part III.

It is not necessary for applicant to provide a separate record of the substance of the interview, since the interview directly resulted in the allowance of the application. The examiner will provide a written summary of the substance of the interview in the Notice of Allowability.

It is not necessary for applicant to provide a separate record of the substance of the interview, since the interview did not result in resolution of all issues. A brief summary by the examiner appears in Part II above.

(Examiner/SPE Signature) _____ (Applicant/Applicant's Representative Signature – if appropriate)

10/18/07
SSP
"O.K. to enter"

I hereby certify that this correspondence is being filed via
EFS-Web with the United States Patent and Trademark Office
on September 4, 2007

AMENDMENT UNDER 37 CFR 1.116
EXPEDITED PROCEDURE -
EXAMINING GROUP 2876

TOWNSEND and TOWNSEND and CREW LLP

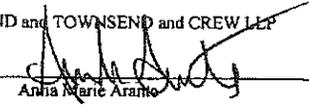
By: 
Anita Marie Aranto

PATENT
Attorney Docket No.: 080379-000100US
Client Ref. No.: F/USP81421X Con.

IN THE UNITED STATES PATENT AND TRADEMARK OFFICE

In re application of:

Herman-ard HULST
Patrick SANDOR

Application No.: 11/~~336~~758

Filed: January 19, 2006

For: DATA STORAGE AND ACCESS
SYSTEMS

Customer No.: 20350

Confirmation No. 3911

Examiner: PAIK, Steve S.

Technology Center/Art Unit: 2876

AMENDMENT UNDER 37 CFR 1.116
EXPEDITED PROCEDURE EXAMINING
GROUP 2876

Mail Stop AF
Commissioner for Patents
P.O. Box 1450
Alexandria, VA 22313-1450

Sir:

In response to the **Final Office Action** mailed May 3, 2007, on the above-referenced application, and in accordance with the one month **Petition for Extension of Time**, extending the time for response (including the Labor Day holiday of September 3) to today, September 4, 2007, please enter the following amendments and remarks:

Amendments to the Claims are reflected in the listing of claims which begins on page 2 of this paper.

Remarks/Arguments begin on page 7 of this paper.



UNITED STATES PATENT AND TRADEMARK OFFICE

UNITED STATES DEPARTMENT OF COMMERCE
 United States Patent and Trademark Office
 Address: COMMISSIONER FOR PATENTS
 P.O. Box 1450
 Alexandria, Virginia 22313-1450
 www.uspto.gov

BIB DATA SHEET

CONFIRMATION NO. 3911

| | | | | | |
|--|---|--|-------------------------------|---|---------------------------------|
| SERIAL NUMBER 11/336,758 | FILING or 371(c) DATE 01/19/2006 | CLASS 235 | GROUP ART UNIT 2876 | ATTORNEY DOCKET NO. 080379-000100US | |
| APPLICANTS Hermen-ard Hulst, Amsterdam, NETHERLANDS; Patrick Sandor Racz, St. Heller, UNITED KINGDOM; ** CONTINUING DATA ***** This application is a CON of 10/111,716 09/17/2002 ABN which is a 371 of PCT/GB00/04110 10/25/2000 ** FOREIGN APPLICATIONS ***** UNITED KINGDOM 9925227.2 11/25/1999 ** IF REQUIRED, FOREIGN FILING LICENSE GRANTED ** ** SMALL ENTITY ** 03/01/2006 | | | | | |
| Foreign Priority claimed <input checked="" type="checkbox"/> Yes <input type="checkbox"/> No 35 USC 119(a-d) conditions met <input checked="" type="checkbox"/> Yes <input type="checkbox"/> No Verified and Acknowledged <u>/STEVEN S PAIK/</u> Examiner's Signature | <input type="checkbox"/> Met after Allowance ssp Initials | STATE OR COUNTRY NETHERLANDS | SHEETS DRAWINGS 17 | TOTAL CLAIMS 18 | INDEPENDENT CLAIMS 18 |
| ADDRESS TOWNSEND AND TOWNSEND AND CREW, LLP TWO EMBARCADERO CENTER EIGHTH FLOOR SAN FRANCISCO, CA 94111-3834 UNITED STATES | | | | | |
| TITLE Data storage and access systems | | | | | |
| FILING FEE RECEIVED 3150 | FEES: Authority has been given in Paper No. _____ to charge/credit DEPOSIT ACCOUNT No. _____ for following: | | | <input type="checkbox"/> All Fees <input type="checkbox"/> 1.16 Fees (Filing) <input type="checkbox"/> 1.17 Fees (Processing Ext. of time) <input type="checkbox"/> 1.18 Fees (Issue) <input type="checkbox"/> Other _____ <input type="checkbox"/> Credit | |

| | | | |
|--|-------------------------|---|--|
| Issue Classification  | Application/Control No. | Applicant(s)/Patent under Reexamination | |
| | 11/336,758 | HULST ET AL. | |
| | Examiner | Art Unit | |
| | Steven S. Paik | 2876 | |

| ISSUE CLASSIFICATION | | | | | | | | | | | | | | |
|-------------------------------------|----------|---|---|------|--|-----------------------------------|-----|-----|--|--------------------------|--|-----------------|--|--|
| ORIGINAL | | | | | CROSS REFERENCE(S) | | | | | | | | | |
| CLASS | SUBCLASS | | | | CLASS | SUBCLASS (ONE SUBCLASS PER BLOCK) | | | | | | | | |
| 230 | 380 | | | | 235 | 382 | 492 | 451 | | | | | | |
| INTERNATIONAL CLASSIFICATION | | | | | | | | | | | | | | |
| G | 0 | 6 | K | 5/00 | | | | | | | | | | |
| | | | | / | | | | | | | | | | |
| | | | | / | | | | | | | | | | |
| | | | | / | | | | | | | | | | |
| | | | | / | | | | | | | | | | |
| (Assistant Examiner) (Date) | | | | |  Steven S. Paik 9/18/07 (Primary Examiner) (Date) | | | | | Total Claims Allowed: 18 | | | | |
| (Legal Instruments Examiner) (Date) | | | | | | | | | | O.G. Print Claim(s) | | O.G. Print Fig. | | |
| | | | | | 1 | | 9 | | | | | | | |

| <input type="checkbox"/> Claims renumbered in the same order as presented by applicant | | <input type="checkbox"/> CPA | | <input type="checkbox"/> T.D. | | <input type="checkbox"/> R.1.47 | |
|--|----------|------------------------------|----------|-------------------------------|----------|---------------------------------|----------|
| Final | Original | Final | Original | Final | Original | Final | Original |
| | 1 | | 31 | | 61 | | 91 |
| | 2 | | 32 | | 62 | | 92 |
| | 3 | | 33 | | 63 | | 93 |
| | 4 | | 34 | | 64 | | 94 |
| | 5 | 3 | 35 | | 65 | | 95 |
| | 6 | 4 | 36 | | 66 | | 96 |
| | 7 | 5 | 37 | | 67 | | 97 |
| | 8 | 6 | 38 | | 68 | | 98 |
| | 9 | 7 | 39 | | 69 | | 99 |
| | 10 | 8 | 40 | | 70 | | 100 |
| | 11 | 9 | 41 | | 71 | | 101 |
| | 12 | 10 | 42 | | 72 | | 102 |
| | 13 | 11 | 43 | | 73 | | 103 |
| | 14 | 12 | 44 | | 74 | | 104 |
| | 15 | 13 | 45 | | 75 | | 105 |
| | 16 | 14 | 46 | | 76 | | 106 |
| | 17 | 15 | 47 | | 77 | | 107 |
| | 18 | 16 | 48 | | 78 | | 108 |
| | 19 | 18 | 49 | | 79 | | 109 |
| | 20 | 17 | 50 | | 80 | | 110 |
| | 21 | | 51 | | 81 | | 111 |
| 1 | 22 | | 52 | | 82 | | 112 |
| 2 | 23 | | 53 | | 83 | | 113 |
| | 24 | | 54 | | 84 | | 114 |
| | 25 | | 55 | | 85 | | 115 |
| | 26 | | 56 | | 86 | | 116 |
| | 27 | | 57 | | 87 | | 117 |
| | 28 | | 58 | | 88 | | 118 |
| | 29 | | 59 | | 89 | | 119 |
| | 30 | | 60 | | 90 | | 120 |
| | | | | | | | 121 |
| | | | | | | | 122 |
| | | | | | | | 123 |
| | | | | | | | 124 |
| | | | | | | | 125 |
| | | | | | | | 126 |
| | | | | | | | 127 |
| | | | | | | | 128 |
| | | | | | | | 129 |
| | | | | | | | 130 |
| | | | | | | | 131 |
| | | | | | | | 132 |
| | | | | | | | 133 |
| | | | | | | | 134 |
| | | | | | | | 135 |
| | | | | | | | 136 |
| | | | | | | | 137 |
| | | | | | | | 138 |
| | | | | | | | 139 |
| | | | | | | | 140 |
| | | | | | | | 141 |
| | | | | | | | 142 |
| | | | | | | | 143 |
| | | | | | | | 144 |
| | | | | | | | 145 |
| | | | | | | | 146 |
| | | | | | | | 147 |
| | | | | | | | 148 |
| | | | | | | | 149 |
| | | | | | | | 150 |
| | | | | | | | 151 |
| | | | | | | | 152 |
| | | | | | | | 153 |
| | | | | | | | 154 |
| | | | | | | | 155 |
| | | | | | | | 156 |
| | | | | | | | 157 |
| | | | | | | | 158 |
| | | | | | | | 159 |
| | | | | | | | 160 |
| | | | | | | | 161 |
| | | | | | | | 162 |
| | | | | | | | 163 |
| | | | | | | | 164 |
| | | | | | | | 165 |
| | | | | | | | 166 |
| | | | | | | | 167 |
| | | | | | | | 168 |
| | | | | | | | 169 |
| | | | | | | | 170 |
| | | | | | | | 171 |
| | | | | | | | 172 |
| | | | | | | | 173 |
| | | | | | | | 174 |
| | | | | | | | 175 |
| | | | | | | | 176 |
| | | | | | | | 177 |
| | | | | | | | 178 |
| | | | | | | | 179 |
| | | | | | | | 180 |
| | | | | | | | 181 |
| | | | | | | | 182 |
| | | | | | | | 183 |
| | | | | | | | 184 |
| | | | | | | | 185 |
| | | | | | | | 186 |
| | | | | | | | 187 |
| | | | | | | | 188 |
| | | | | | | | 189 |
| | | | | | | | 190 |
| | | | | | | | 191 |
| | | | | | | | 192 |
| | | | | | | | 193 |
| | | | | | | | 194 |
| | | | | | | | 195 |
| | | | | | | | 196 |
| | | | | | | | 197 |
| | | | | | | | 198 |
| | | | | | | | 199 |
| | | | | | | | 200 |
| | | | | | | | 201 |
| | | | | | | | 202 |
| | | | | | | | 203 |
| | | | | | | | 204 |
| | | | | | | | 205 |
| | | | | | | | 206 |
| | | | | | | | 207 |
| | | | | | | | 208 |
| | | | | | | | 209 |
| | | | | | | | 210 |

Index of Claims



Application/Control No.

11/336,758

Examiner

Steven S. Paik

Applicant(s)/Patent under Reexamination

HULST ET AL.

Art Unit

2876

| | |
|---|----------|
| √ | Rejected |
| ≡ | Allowed |

| | |
|---|--------------------------------|
| - | (Through numeral) Cancelled |
| + | Restricted |

| | |
|---|--------------|
| N | Non-Elected |
| I | Interference |

| | |
|---|----------|
| A | Appeal |
| O | Objected |

| Claim | | Date | | | |
|-------|----------|---------|--|--|--|
| Final | Original | 9/18/07 | | | |
| | 1 | | | | |
| | 2 | | | | |
| | 3 | | | | |
| | 4 | | | | |
| | 5 | | | | |
| | 6 | | | | |
| | 7 | | | | |
| | 8 | | | | |
| | 9 | | | | |
| | 10 | | | | |
| | 11 | | | | |
| | 12 | | | | |
| | 13 | | | | |
| | 14 | | | | |
| | 15 | | | | |
| | 16 | | | | |
| | 17 | | | | |
| | 18 | | | | |
| | 19 | | | | |
| | 20 | | | | |
| | 21 | | | | |
| 1 | 22 | = | | | |
| 2 | 23 | = | | | |
| | 24 | | | | |
| | 25 | | | | |
| | 26 | | | | |
| | 27 | | | | |
| | 28 | | | | |
| | 29 | | | | |
| | 30 | | | | |
| | 31 | | | | |
| | 32 | | | | |
| | 33 | | | | |
| | 34 | | | | |
| 3 | 35 | = | | | |
| 4 | 36 | = | | | |
| 5 | 37 | = | | | |
| 6 | 38 | = | | | |
| 7 | 39 | = | | | |
| 8 | 40 | = | | | |
| 9 | 41 | = | | | |
| 10 | 42 | = | | | |
| 11 | 43 | = | | | |
| 12 | 44 | = | | | |
| 13 | 45 | = | | | |
| 14 | 46 | = | | | |
| 15 | 47 | = | | | |
| 16 | 48 | = | | | |
| 18 | 49 | = | | | |
| 17 | 50 | = | | | |

| Claim | | Date | | | |
|-------|----------|---------|--|--|--|
| Final | Original | 9/18/07 | | | |
| | 51 | | | | |
| | 52 | | | | |
| | 53 | | | | |
| | 54 | | | | |
| | 55 | | | | |
| | 56 | | | | |
| | 57 | | | | |
| | 58 | | | | |
| | 59 | | | | |
| | 60 | | | | |
| | 61 | | | | |
| | 62 | | | | |
| | 63 | | | | |
| | 64 | | | | |
| | 65 | | | | |
| | 66 | | | | |
| | 67 | | | | |
| | 68 | | | | |
| | 69 | | | | |
| | 70 | | | | |
| | 71 | | | | |
| | 72 | | | | |
| | 73 | | | | |
| | 74 | | | | |
| | 75 | | | | |
| | 76 | | | | |
| | 77 | | | | |
| | 78 | | | | |
| | 79 | | | | |
| | 80 | | | | |
| | 81 | | | | |
| | 82 | | | | |
| | 83 | | | | |
| | 84 | | | | |
| | 85 | | | | |
| | 86 | | | | |
| | 87 | | | | |
| | 88 | | | | |
| | 89 | | | | |
| | 90 | | | | |
| | 91 | | | | |
| | 92 | | | | |
| | 93 | | | | |
| | 94 | | | | |
| | 95 | | | | |
| | 96 | | | | |
| | 97 | | | | |
| | 98 | | | | |
| | 99 | | | | |
| | 100 | | | | |

| Claim | | Date | | | |
|-------|----------|------|--|--|--|
| Final | Original | | | | |
| | 101 | | | | |
| | 102 | | | | |
| | 103 | | | | |
| | 104 | | | | |
| | 105 | | | | |
| | 106 | | | | |
| | 107 | | | | |
| | 108 | | | | |
| | 109 | | | | |
| | 110 | | | | |
| | 111 | | | | |
| | 112 | | | | |
| | 113 | | | | |
| | 114 | | | | |
| | 115 | | | | |
| | 116 | | | | |
| | 117 | | | | |
| | 118 | | | | |
| | 119 | | | | |
| | 120 | | | | |
| | 121 | | | | |
| | 122 | | | | |
| | 123 | | | | |
| | 124 | | | | |
| | 125 | | | | |
| | 126 | | | | |
| | 127 | | | | |
| | 128 | | | | |
| | 129 | | | | |
| | 130 | | | | |
| | 131 | | | | |
| | 132 | | | | |
| | 133 | | | | |
| | 134 | | | | |
| | 135 | | | | |
| | 136 | | | | |
| | 137 | | | | |
| | 138 | | | | |
| | 139 | | | | |
| | 140 | | | | |
| | 141 | | | | |
| | 142 | | | | |
| | 143 | | | | |
| | 144 | | | | |
| | 145 | | | | |
| | 146 | | | | |
| | 147 | | | | |
| | 148 | | | | |
| | 149 | | | | |
| | 150 | | | | |

Search Notes



Application/Control No.

11/336,758

Examiner

Steven S. Paik

Applicant(s)/Patent under Reexamination

HULST ET AL.

Art Unit

2876

SEARCHED

| Class | Subclass | Date | Examiner |
|---------|----------|-----------|----------|
| 235 | 380 | | |
| | 382 | | |
| | 492 | | |
| | 451 | | |
| 711 | 100 | | |
| | 101 | | |
| | 103 | | |
| updated | | 9/18/2007 | SSP |
| | | | |
| | | | |
| | | | |
| | | | |
| | | | |

INTERFERENCE SEARCHED

| Class | Subclass | Date | Examiner |
|---------|----------|-----------|----------|
| same as | above | 9/18/2007 | SSP |
| | | | |
| | | | |

**SEARCH NOTES
(INCLUDING SEARCH STRATEGY)**

| | DATE | EXMR |
|---|-----------|------|
| EAST | | |
| Text search combined with 235/\$7.ccls. | | |
| Reviewed 10/111,716 | | |
| updated | 9/18/2007 | SSP |
| | | |
| | | |
| | | |
| | | |
| | | |

EAST Search History

| Ref # | Hits | Search Query | DBs | Default Operator | Plurals | Time Stamp |
|-------|------|---|--|------------------|---------|------------------|
| S19 | 2 | ("20060118619").PN. | US-PGPUB; USPAT; USOCR; FPRS; EPO; JPO; DERWENT; IBM_TDB | OR | OFF | 2007/09/18 22:03 |
| S18 | 105 | ((data adj carrier) or (IC or chip or memory or smart) adj4 card) near40 ((use or usage or user) near40 (rule or agreement or procedure)) and "235"/\$7.ccls. | US-PGPUB; USPAT; USOCR; FPRS; EPO; JPO; DERWENT; IBM_TDB | OR | ON | 2007/09/18 22:03 |
| S17 | 13 | ((data adj carrier) or (IC or chip or memory or smart) adj4 card) near40 ((use or usage or user) near40 (rule or agreement or procedure)) and "711"/\$7.ccls. | US-PGPUB; USPAT; USOCR; FPRS; EPO; JPO; DERWENT; IBM_TDB | OR | ON | 2007/09/18 19:51 |
| S15 | 710 | ((data adj carrier) or (IC or chip or memory or smart) adj4 card) near40 ((use or usage or user) near40 (rule or agreement or procedure)) | US-PGPUB; USPAT; USOCR; FPRS; EPO; JPO; DERWENT; IBM_TDB | OR | ON | 2007/09/18 19:50 |
| S16 | 11 | ((data adj carrier) or (IC or chip or memory or smart) adj4 card) near40 ((use or usage or user) near40 (rule or agreement or procedure)) near40 (status) | US-PGPUB; USPAT; USOCR; FPRS; EPO; JPO; DERWENT; IBM_TDB | OR | ON | 2007/09/18 19:00 |
| S2 | 1411 | 235/382.ccls. | US-PGPUB; USPAT; USOCR; FPRS; EPO; JPO; DERWENT; IBM_TDB | OR | ON | 2007/09/18 18:56 |
| S14 | 2 | "20060071075" | US-PGPUB; USPAT; USOCR; FPRS; EPO; JPO; DERWENT; IBM_TDB | OR | ON | 2007/09/17 16:23 |

EAST Search History

| | | | | | | |
|-----|------|---------------|--|----|----|------------------|
| S13 | 199 | 705/77.ccls. | US-PGPUB; USPAT; USOCR; FPRS; EPO; JPO; DERWENT; IBM_TDB | OR | ON | 2007/09/13 20:40 |
| S12 | 1690 | 711/100.ccls. | US-PGPUB; USPAT; USOCR; FPRS; EPO; JPO; DERWENT; IBM_TDB | OR | ON | 2007/09/13 20:40 |

PATENT APPLICATION FEE DETERMINATION RECORD
Effective December 8, 2004

11/336,758

| AMENDMENT | (Column 1) | | (Column 2) | (Column 3) |
|---|----------------------------------|-------|------------------------------------|---------------|
| | CLAIMS REMAINING AFTER AMENDMENT | | HIGHEST NUMBER PREVIOUSLY PAID FOR | PRESENT EXTRA |
| Total | * 18 | Minus | ** 74 | = |
| Independent | * 4 | Minus | *** 16 | = |
| FIRST PRESENTATION OF MULTIPLE DEPENDENT CLAIM <input type="checkbox"/> | | | | |

| RATE | ADDITIONAL FEE | OR | RATE | ADDITIONAL FEE |
|------------------|----------------|----|------------------|----------------|
| X\$ 25= | | | X\$50= | |
| X100= | | | X200= | |
| +180= | | | +360= | |
| TOTAL ADDIT. FEE | | | TOTAL ADDIT. FEE | |

| AMENDMENT | (Column 1) | | (Column 2) | (Column 3) |
|---|----------------------------------|-------|------------------------------------|---------------|
| | CLAIMS REMAINING AFTER AMENDMENT | | HIGHEST NUMBER PREVIOUSLY PAID FOR | PRESENT EXTRA |
| Total | * | Minus | ** | = |
| Independent | * | Minus | *** | = |
| FIRST PRESENTATION OF MULTIPLE DEPENDENT CLAIM <input type="checkbox"/> | | | | |

| RATE | ADDITIONAL FEE | OR | RATE | ADDITIONAL FEE |
|------------------|----------------|----|------------------|----------------|
| X\$ 25= | | | X\$50= | |
| X100= | | | X200= | |
| +180= | | | +360= | |
| TOTAL ADDIT. FEE | | | TOTAL ADDIT. FEE | |

| AMENDMENT | (Column 1) | | (Column 2) | (Column 3) |
|---|----------------------------------|-------|------------------------------------|---------------|
| | CLAIMS REMAINING AFTER AMENDMENT | | HIGHEST NUMBER PREVIOUSLY PAID FOR | PRESENT EXTRA |
| Total | * | Minus | ** | = |
| Independent | * | Minus | *** | = |
| FIRST PRESENTATION OF MULTIPLE DEPENDENT CLAIM <input type="checkbox"/> | | | | |

| RATE | ADDITIONAL FEE | OR | RATE | ADDITIONAL FEE |
|------------------|----------------|----|------------------|----------------|
| X\$ 25= | | | X\$50= | |
| X100= | | | X200= | |
| +180= | | | +360= | |
| TOTAL ADDIT. FEE | | | TOTAL ADDIT. FEE | |

| AMENDMENT | (Column 1) | | (Column 2) | (Column 3) |
|---|----------------------------------|-------|------------------------------------|---------------|
| | CLAIMS REMAINING AFTER AMENDMENT | | HIGHEST NUMBER PREVIOUSLY PAID FOR | PRESENT EXTRA |
| Total | * | Minus | ** | = |
| Independent | * | Minus | *** | = |
| FIRST PRESENTATION OF MULTIPLE DEPENDENT CLAIM <input type="checkbox"/> | | | | |

| RATE | ADDITIONAL FEE | OR | RATE | ADDITIONAL FEE |
|---------|----------------|----|--------|----------------|
| X\$ 25= | | | X\$50= | |
| X100= | | | X200= | |
| +180= | | | +360= | |

11/30/75B

| Claim | | Date |
|-------|----------|------|
| Final | Original | |
| | 1 | |
| | 2 | |
| | 3 | |
| | 4 | |
| | 5 | |
| | 6 | |
| | 7 | |
| | 8 | |
| | 9 | |
| | 10 | |
| | 11 | |
| | 12 | |
| | 13 | |
| | 14 | |
| | 15 | |
| | 16 | |
| | 17 | |
| | 18 | |
| | 19 | |
| | 20 | |
| | 21 | |
| | 22 | |
| | 23 | |
| | 24 | |
| | 25 | |
| | 26 | |
| | 27 | |
| | 28 | |
| | 29 | |
| | 30 | |
| | 31 | |
| | 32 | |
| | 33 | |
| | 34 | |
| | 35 | |
| | 36 | |
| | 37 | |
| | 38 | |
| | 39 | |
| | 40 | |
| | 41 | |
| | 42 | |
| | 43 | |
| | 44 | |
| | 45 | |
| | 46 | |
| | 47 | |
| | 48 | |
| | 49 | |
| | 50 | |

| Claim | | Date |
|-------|----------|------|
| Final | Original | |
| | 51 | |
| | 52 | |
| | 53 | |
| | 54 | |
| | 55 | |
| | 56 | |
| | 57 | |
| | 58 | |
| | 59 | |
| | 60 | |
| | 61 | |
| | 62 | |
| | 63 | |
| | 64 | |
| | 65 | |
| | 66 | |
| | 67 | |
| | 68 | |
| | 69 | |
| | 70 | |
| | 71 | |
| | 72 | |
| | 73 | |
| | 74 | |
| | 75 | |
| | 76 | |
| | 77 | |
| | 78 | |
| | 79 | |
| | 80 | |
| | 81 | |
| | 82 | |
| | 83 | |
| | 84 | |
| | 85 | |
| | 86 | |
| | 87 | |
| | 88 | |
| | 89 | |
| | 90 | |
| | 91 | |
| | 92 | |
| | 93 | |
| | 94 | |
| | 95 | |
| | 96 | |
| | 97 | |
| | 98 | |
| | 99 | |
| | 100 | |

| Claim | | Date |
|-------|----------|------|
| Final | Original | |
| | 101 | |
| | 102 | |
| | 103 | |
| | 104 | |
| | 105 | |
| | 106 | |
| | 107 | |
| | 108 | |
| | 109 | |
| | 110 | |
| | 111 | |
| | 112 | |
| | 113 | |
| | 114 | |
| | 115 | |
| | 116 | |
| | 117 | |
| | 118 | |
| | 119 | |
| | 120 | |
| | 121 | |
| | 122 | |
| | 123 | |
| | 124 | |
| | 125 | |
| | 126 | |
| | 127 | |
| | 128 | |
| | 129 | |
| | 130 | |
| | 131 | |
| | 132 | |
| | 133 | |
| | 134 | |
| | 135 | |
| | 136 | |
| | 137 | |
| | 138 | |
| | 139 | |
| | 140 | |
| | 141 | |
| | 142 | |
| | 143 | |
| | 144 | |
| | 145 | |
| | 146 | |
| | 147 | |
| | 148 | |
| | 149 | |
| | 150 | |

If more than 160 claims or 10 actions
staple additional sheet here

(LEFT INSIDE)

I hereby certify that this correspondence is being filed via
EFS-Web with the United States Patent and Trademark Office
on September 4, 2007

AMENDMENT UNDER 37 CFR 1.116
EXPEDITED PROCEDURE –
EXAMINING GROUP 2876

TOWNSEND and TOWNSEND and CREW LLP

By: _____

Anha Marie Arante

PATENT

Attorney Docket No.: 080379-000100US

Client Ref. No.: F/USP81421X Con.

IN THE UNITED STATES PATENT AND TRADEMARK OFFICE

In re application of:

Herman-ard HULST
Patrick SANDOR

Application No.: 11/336,758

Filed: January 19, 2006

For: DATA STORAGE AND ACCESS
SYSTEMS

Customer No.: 20350

Confirmation No. 3911

Examiner: PAIK, Steve S.

Technology Center/Art Unit: 2876

AMENDMENT UNDER 37 CFR 1.116
EXPEDITED PROCEDURE EXAMINING
GROUP 2876

Mail Stop AF
Commissioner for Patents
P.O. Box 1450
Alexandria, VA 22313-1450

Sir:

In response to the **Final Office Action** mailed May 3, 2007, on the above-referenced application, and in accordance with the one month **Petition for Extension of Time**, extending the time for response (including the Labor Day holiday of September 3) to today, September 4, 2007, please enter the following amendments and remarks:

Amendments to the Claims are reflected in the listing of claims which begins on page 2 of this paper.

Remarks/Arguments begin on page 7 of this paper.

Amendments to the Claims:

This listing of claims will replace all prior versions, and listings, of claims in the application:

Listing of Claims:

Claims 1-21. (Canceled)

22. (Previously Presented) A method of controlling access to content data on a data carrier, the data carrier comprising non-volatile data memory storing content memory and non-volatile parameter memory storing use status data and use rules, the method comprising:

- receiving a data access request from a user for at least one content item of the content data stored in the non-volatile data memory;
- reading the use status data and use rules from the parameter memory that pertain to use of the at least one requested content item;
- evaluating the use status data using the use rules to determine whether access to the at least one requested content item stored in the content memory is permitted; and
- displaying to the user whether access is permitted for each of the at least one requested content item stored in the non-volatile data memory.

23. (Original) A method as claimed in claim 22 wherein said parameter memory further stores payment data and further comprising selecting a said use rule dependent upon said payment data.

Claims 24-34. (Canceled)

35. (Previously Presented) A data access terminal for retrieving data from a data supplier and providing the retrieved data to a data carrier, the terminal comprising:

- a first interface for communicating with the data supplier;
- a data carrier interface for interfacing with the data carrier;

a program store storing code; and
a processor coupled to the first interface, the data carrier interface, and the program store for implementing the stored code, the code comprising:
code to read payment data from the data carrier and to forward the payment data to a payment validation system;
code to receive payment validation data from the payment validation system;
code responsive to the payment validation data to retrieve data from the data supplier and to write the retrieved data into the data carrier; and
code responsive to the payment validation data to receive at least one access rule from the data supplier and to write the at least one access rule into the data carrier, the at least one access rule specifying at least one condition for accessing the retrieved data written into the data carrier, the at least one condition being dependent upon the amount of payment associated with the payment data forwarded to the payment validation system.

36. (Original) A data access terminal as claimed in claim 35 further comprising code to transmit at least a portion of the payment validation data to the data supplier or to a destination received from the data supplier.

37. (Previously Presented) A data access terminal as claimed in claim 35 further comprising code to retrieve from the data supplier and output to a user stored data identifier data and associated value data and use rule data for a data item available from the data supplier.

38. (Original) A data access terminal as claimed in claim 37 further comprising code to write use rule data for a data item into the data carrier with the associated data item.

39. (Currently Amended) A data access terminal as claimed in claim 37 further comprising code to read a stored value from the data carrier, code to compare said stored value with said value data, [[:]] and code to provide a modified output to a user of one or more of

said stored data identifier data, said value data and said use rule data, in response to a result of the comparison.

40. (Previously Presented) A data access terminal according to claim 35 further comprising code for user input of access control data, code to output the access control data to the data carrier, and code to receive access permission data and output data to the user in response to the received access permission data.

41. (Previously Presented) A data access terminal as claimed in claim 40 further comprising code to output a data erasure warning in response to the received access permission data.

42. (Previously Presented) A data access terminal according to claim 35 further comprising code to read reward data from the data carrier and to write modified reward data to the data carrier in response to said retrieval of data from the data supplier.

43. (Previously Presented) A data access terminal according to claim 35 further comprising:
code to read identity data from the data carrier;
code to transmit the identity data to the data supplier;
code to receive user characterizing data from the data supplier;
code to retrieve supplementary data in response to said characterizing data; and
code to output the supplementary data.

44. (Previously Presented) A data access terminal according to claim 35 further comprising a cash input device coupled to the processor, to provide cash input value data; and code to update payment data in the data carrier, in accordance with the cash input value data.

45. (Previously Presented) A data access terminal according to claim 35 integrated with a mobile communication device, a personal computer, an audio/video player, and/or a cable or satellite television interface device.

46. (Previously Presented) A method of providing data from a data supplier to a data carrier, the method comprising:

- reading payment data from the data carrier;
- forwarding the payment data to a payment validation system;
- retrieving data from the data supplier;
- writing the retrieved data into the data carrier;
- receiving at least one access rule from the data supplier; and
- writing the at least one access rule into the data carrier, the at least one access rule specifying at least one condition for accessing the retrieved data written into the data carrier, the at least one condition being dependent upon the amount of payment associated with the payment data forwarded to the payment validation system.

47. (Original) A method of providing data from a data supplier according to claim 46 further comprising:

- receiving payment validation data from the payment validation system; and
- transmitting at least a portion of the payment validation data to the data supplier.

48. (Original) A method of providing data as claimed in claim 47, wherein the payment validation system comprises a payment processor at the data supplier.

49. (Previously Presented) A method of providing data as claimed in claim 46, further comprising:

- retrieving from the data supplier a stored data item identifier and associated value data; and
- writing the stored data item identifier and associated value data for the data item into the data carrier.

50. (Previously Presented) A method of providing data as claimed in claim 48, further comprising:

- reading a stored value from the data carrier;

Appl. No. 11/336,758
Amdt. dated September 4, 2007
Amendment under 37 CFR 1.116 Expedited Procedure
Examining Group 2876

PATENT

comparing the stored value with said value data; and
outputting to a user information indicating the result of said comparing.

Claims 51-74. (Canceled)

REMARKS/ARGUMENTS

This Amendment is in response to the Office Action mailed May 3, 2007. Claims 22, 23, 35-50, and 59-62 were pending in the present application. Claims 22, 23, and 35-50 are allowed. This Amendment amends claim 39, and cancels claims 59-62, leaving pending in the application claims 22, 23, and 35-50. Reconsideration of the rejected claims is respectfully requested.

I. Allowed Claims

Claims 22, 23, and 35-50 are allowed.

II. Examiner Interview

An informal telephone interview was conducted with Examiner Paik on May 16, 2007. The undersigned attorney represented the Applicants in the interview. In the interview, the objection to the declaration was discussed. The Examiner indicated that the second was incorrectly copied into the outstanding Office Action and that the declaration is actually in compliance as discussed. The Examiner also clarified the language on page 4 to indicate that the previous response did address claims 59-62, but that the Examiner believes there are separate issues regarding these claims that still render them obvious in light of the cited art. Applicants' appreciate the Examiner's help in these matters.

III. Effectiveness of Declaration

As discussed above, the Examiner indicated by telephone that this section was improperly copied into the Office Action as the declaration includes the correct application number and filing date (the declaration being a copy from the parent case under 37 CFR 1.63). Applicants therefore respectfully submit that the declaration is effective as confirmed by the Examiner.

Appl. No. 11/376,758
Amdt. dated September 4, 2007
Amendment under 37 CFR 1.116 Expedited Procedure
Examining Group 2876

PATENT

IV. Rejection under 35 U.S.C. §102

Claims 59-62 are rejected under 35 U.S.C. §102(b) as being anticipated by *Hiroya et al.* (US 5,754,654). While Applicants disagree with the rejection, for reasons including those of record, these claims are canceled in this response in order to expedite issuance of the allowed claims. Applicants reserve the right to present these or similar claims again in a continuing application. As these claims have been canceled, Applicants respectfully submit that the rejections are moot.

V. Amendment to the Claims

Claim 39 is amended simply for clarification purposes, replacing a semicolon with a comma to be consistent with the rest of the claim. It is respectfully submitted that this amendment is non-substantive, and does not affect the allowability of this claim. The amendment is not intended to alter the scope of the claim or limit any equivalents thereof, is supported by the specification, and does not add new matter. Applicants therefore respectfully request consideration and allowance of the amended claim.

CONCLUSION

In view of the foregoing, Applicants believe all claims now pending in this Application are in condition for allowance and an action to that end is respectfully requested.

If the Examiner believes a telephone conference would expedite prosecution of this application, please telephone the undersigned at 925-472-5000.

Respectfully submitted,



Jason D. Lohr
Reg. No. 48,163

TOWNSEND and TOWNSEND and CREW LLP
Two Embarcadero Center, Eighth Floor
San Francisco, California 94111-3834
Tel: 925-472-5000
Fax: 415-576-0300
Attachments
JDL;jdl
61142387 v1

Electronic Patent Application Fee Transmittal

| | | | | |
|---|-------------------------------------|-----------------|---------------|-----------------------------|
| Application Number: | 11336758 | | | |
| Filing Date: | 19-Jan-2006 | | | |
| Title of Invention: | Data storage and access systems | | | |
| First Named Inventor/Applicant Name: | Hermen-ard Hulst | | | |
| Filer: | Jason Donald Lohr/Anna Marie Arante | | | |
| Attorney Docket Number: | 080379-000100US | | | |
| Filed as Small Entity | | | | |
| Utility Filing Fees | | | | |
| Description | Fee Code | Quantity | Amount | Sub-Total in USD(\$) |
| Basic Filing: | | | | |
| Pages: | | | | |
| Claims: | | | | |
| Miscellaneous-Filing: | | | | |
| Petition: | | | | |
| Patent-Appeals-and-Interference: | | | | |
| Post-Allowance-and-Post-Issuance: | | | | |
| Extension-of-Time: | | | | |
| Extension - 1 month with \$0 paid | 2251 | 1 | 60 | 60 |

| Description | Fee Code | Quantity | Amount | Sub-Total in USD(\$) |
|-------------------|----------|----------|--------|----------------------|
| Miscellaneous: | | | | |
| Total in USD (\$) | | | | 60 |

Electronic Acknowledgement Receipt

| | |
|---|-------------------------------------|
| EFS ID: | 2157419 |
| Application Number: | 11336758 |
| International Application Number: | |
| Confirmation Number: | 3911 |
| Title of Invention: | Data storage and access systems |
| First Named Inventor/Applicant Name: | Hermen-ard Hulst |
| Customer Number: | 20350 |
| Filer: | Jason Donald Lohr/Anna Marie Arante |
| Filer Authorized By: | Jason Donald Lohr |
| Attorney Docket Number: | 080379-000100US |
| Receipt Date: | 04-SEP-2007 |
| Filing Date: | 19-JAN-2006 |
| Time Stamp: | 21:03:32 |
| Application Type: | Utility under 35 USC 111(a) |

Payment information:

| | |
|--|--------|
| Submitted with Payment | yes |
| Payment was successfully received in RAM | \$60 |
| RAM confirmation Number | 3996 |
| Deposit Account | 201430 |

The Director of the USPTO is hereby authorized to charge indicated fees and credit any overpayment as follows:
 Charge any Additional Fees required under 37 C.F.R. Section 1.16 and 1.17

File Listing:

| Document Number | Document Description | File Name | File Size(Bytes) /Message Digest | Multi Part /.zip | Pages (if appl.) |
|---|--|---|---|------------------|------------------|
| 1 | | 080379_000100US_RespAfterFinal_09_04_2007.pdf | 399917 6489b52d6f68a911f10cb5a29d0e832a121750493 | yes | 11 |
| Multipart Description/PDF files in .zip description | | | | | |
| | Document Description | | Start | | End |
| | Miscellaneous Incoming Letter | | 1 | | 1 |
| | Extension of Time | | 2 | | 3 |
| | Amendment After Final | | 4 | | 4 |
| | Claims | | 5 | | 9 |
| | Applicant Arguments/Remarks Made in an Amendment | | 10 | | 11 |
| Warnings: | | | | | |
| Information: | | | | | |
| 2 | Fee Worksheet (PTO-06) | fee-info.pdf | 8141 4933baf9490db2556ddcd7d78e005411b05e117b274 | no | 2 |
| Warnings: | | | | | |
| Information: | | | | | |
| Total Files Size (in bytes): | | | 408058 | | |
| <p>This Acknowledgement Receipt evidences receipt on the noted date by the USPTO of the indicated documents, characterized by the applicant, and including page counts, where applicable. It serves as evidence of receipt similar to a Post Card, as described in MPEP 503.</p> <p><u>New Applications Under 35 U.S.C. 111</u> If a new application is being filed and the application includes the necessary components for a filing date (see 37 CFR 1.53(b)-(d) and MPEP 506), a Filing Receipt (37 CFR 1.54) will be issued in due course and the date shown on this Acknowledgement Receipt will establish the filing date of the application.</p> <p><u>National Stage of an International Application under 35 U.S.C. 371</u> If a timely submission to enter the national stage of an international application is compliant with the conditions of 35 U.S.C. 371 and other applicable requirements a Form PCT/DO/EO/903 indicating acceptance of the application as a national stage submission under 35 U.S.C. 371 will be issued in addition to the Filing Receipt, in due course.</p> <p><u>New International Application Filed with the USPTO as a Receiving Office</u> If a new international application is being filed and the international application includes the necessary components for an international filing date (see PCT Article 11 and MPEP 1810), a Notification of the International Application Number and of the International Filing Date (Form PCT/RO/105) will be issued in due course, subject to prescriptions concerning national security, and the date shown on this Acknowledgement Receipt will establish the international filing date of the application.</p> | | | | | |

| | | |
|--|------------------------|-------------------|
| TRANSMITTAL FORM <small>(to be used for all correspondence after initial filing)</small> | Application Number | 11/376,758 |
| | Filing Date | January 19, 2006 |
| | First Named Inventor | Hulst, Herman-ard |
| | Art Unit | 2876 |
| | Examiner Name | PAIK, Steve S. |
| | Attorney Docket Number | 080379-000100US |
| Total Number of Pages in This Submission | | |

| ENCLOSURES (Check all that apply) | | |
|---|---|---|
| <input type="checkbox"/> Fee Transmittal Form | <input type="checkbox"/> Drawing(s) | <input type="checkbox"/> After Allowance Communication to TC |
| <input type="checkbox"/> Fee Attached | <input type="checkbox"/> Licensing-related Papers | <input type="checkbox"/> Appeal Communication to Board of Appeals and Interferences |
| <input checked="" type="checkbox"/> Amendment/Reply (8 pgs.) | <input type="checkbox"/> Petition | <input type="checkbox"/> Appeal Communication to TC (Appeal Notice, Brief, Reply Brief) |
| <input checked="" type="checkbox"/> After Final | <input type="checkbox"/> Petition to Convert to a Provisional Application | <input type="checkbox"/> Proprietary Information |
| <input type="checkbox"/> Affidavits/declaration(s) | <input type="checkbox"/> Power of Attorney, Revocation | <input type="checkbox"/> Status Letter |
| <input checked="" type="checkbox"/> Extension of Time Request (1 orig., 1 copy) | <input type="checkbox"/> Change of Correspondence Address | <input type="checkbox"/> Other Enclosure(s) (please identify below): |
| <input type="checkbox"/> Express Abandonment Request | <input type="checkbox"/> Terminal Disclaimer | |
| <input type="checkbox"/> Information Disclosure Statement | <input type="checkbox"/> Request for Refund | |
| <input type="checkbox"/> Certified Copy of Priority Document(s) | <input type="checkbox"/> CD, Number of CD(s) _____ | |
| <input type="checkbox"/> Reply to Missing Parts/ Incomplete Application | <input type="checkbox"/> Landscape Table on CD | |
| <input type="checkbox"/> Reply to Missing Parts under 37 CFR 1.52 or 1.53 | Remarks The Commissioner is authorized to charge any additional fees to Deposit Account 20-1430. | |

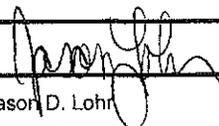
| SIGNATURE OF APPLICANT, ATTORNEY, OR AGENT | | | |
|--|---|----------|--------|
| Firm Name | Townsend and Townsend and Crew LLP | | |
| Signature |  | | |
| Printed name | Jason D. Lohr | | |
| Date | September 4, 2007 | Reg. No. | 48,163 |

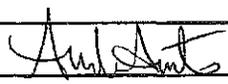
| CERTIFICATE OF TRANSMISSION/MAILING | | | |
|--|---|------|-------------------|
| I hereby certify that this correspondence is being filed via EFS-Web with the United States Patent and Trademark Office on the date shown below. | | | |
| Signature |  | | |
| Typed or printed name | Anna Marie Arante | Date | September 4, 2007 |

| PETITION FOR EXTENSION OF TIME UNDER 37 CFR 1.136(a) | | Docket Number (Optional) 080379-000100US Client Ref. No.: F/USP81421X Con. | | | | | | | | | | | | | | | | | | | | | | | | | |
|---|--------|---|-------------|--|-----|------------------|--|---|-------|------|-------------|---|-------|-------|----------|---|--------|-------|----------|--|--------|-------|----------|--|--------|--------|----------|
| FY 2007 <i>(Fees pursuant to the Consolidated Appropriations Act, 2005 (H.R. 4818).)</i> | | | | | | | | | | | | | | | | | | | | | | | | | | | |
| Application Number 11/376,758 | | Filed January 19, 2006 | | | | | | | | | | | | | | | | | | | | | | | | | |
| For DATA STORAGE AND ACCESS SYSTEMS | | | | | | | | | | | | | | | | | | | | | | | | | | | |
| Art Unit 2876 | | Examiner PAIK, Steve S. | | | | | | | | | | | | | | | | | | | | | | | | | |
| <p>This is a request under the provisions of 37 CFR 1.136(a) to extend the period for filing a reply in the above identified application.</p> <p>The requested extension and fee are as follows (check time period desired and enter the appropriate fee below):</p> <table border="0" style="width: 100%;"> <thead> <tr> <th></th> <th style="text-align: center;">Fee</th> <th colspan="2" style="text-align: center;">Small Entity Fee</th> </tr> </thead> <tbody> <tr> <td><input checked="" type="checkbox"/> One month (37 CFR 1.17(a)(1))</td> <td style="text-align: center;">\$120</td> <td style="text-align: center;">\$60</td> <td style="text-align: center;">\$ 60 _____</td> </tr> <tr> <td><input type="checkbox"/> Two months (37 CFR 1.17(a)(2))</td> <td style="text-align: center;">\$450</td> <td style="text-align: center;">\$225</td> <td style="text-align: center;">\$ _____</td> </tr> <tr> <td><input type="checkbox"/> Three months (37 CFR 1.17(a)(3))</td> <td style="text-align: center;">\$1020</td> <td style="text-align: center;">\$510</td> <td style="text-align: center;">\$ _____</td> </tr> <tr> <td><input type="checkbox"/> Four months (37 CFR 1.17(a)(4))</td> <td style="text-align: center;">\$1590</td> <td style="text-align: center;">\$795</td> <td style="text-align: center;">\$ _____</td> </tr> <tr> <td><input type="checkbox"/> Five months (37 CFR 1.17(a)(5))</td> <td style="text-align: center;">\$2160</td> <td style="text-align: center;">\$1080</td> <td style="text-align: center;">\$ _____</td> </tr> </tbody> </table> <p><input checked="" type="checkbox"/> Applicant claims small entity status. See 37 CFR 1.27.</p> <p><input type="checkbox"/> A check in the amount of the fee is enclosed.</p> <p><input type="checkbox"/> Payment by credit card. Form PTO-2038 is attached.</p> <p><input checked="" type="checkbox"/> The Director has already been authorized to charge fees in this application to a Deposit Account.</p> <p><input checked="" type="checkbox"/> The Director is hereby authorized to charge any fees which may be required, or credit any overpayment, to Deposit Account Number <u>20-1430</u>. I have enclosed a duplicate copy of this sheet.</p> <p>WARNING: Information on this form may become public. Credit card information should not be included on this form. Provide credit card information and authorization on PTO-2038.</p> <p>I am the <input type="checkbox"/> applicant/inventor.</p> <p><input type="checkbox"/> assignee of record of the entire interest. See 37 CFR 3.71. Statement under 37 CFR 3.73(b) is enclosed (Form PTO/SB/96).</p> <p><input checked="" type="checkbox"/> attorney or agent of record. Registration Number <u>48,163</u></p> <p><input type="checkbox"/> attorney or agent under 37 CFR 1.34. Registration number if acting under 37 CFR 1.34 _____</p> <p>_____ Signature</p> <p>_____ Date</p> <p>_____ Jason D. Lohr, Reg. No. 48,163</p> <p>_____ Telephone Number</p> <p>_____ Telephone Number</p> <p>NOTE: Signatures of all the inventors or assignees of record of the entire interest or their representative(s) are required. Submit multiple forms if more than one signature is required, see below.</p> <p><input checked="" type="checkbox"/> Total of <u>2</u> forms are submitted.</p> | | | | | Fee | Small Entity Fee | | <input checked="" type="checkbox"/> One month (37 CFR 1.17(a)(1)) | \$120 | \$60 | \$ 60 _____ | <input type="checkbox"/> Two months (37 CFR 1.17(a)(2)) | \$450 | \$225 | \$ _____ | <input type="checkbox"/> Three months (37 CFR 1.17(a)(3)) | \$1020 | \$510 | \$ _____ | <input type="checkbox"/> Four months (37 CFR 1.17(a)(4)) | \$1590 | \$795 | \$ _____ | <input type="checkbox"/> Five months (37 CFR 1.17(a)(5)) | \$2160 | \$1080 | \$ _____ |
| | Fee | Small Entity Fee | | | | | | | | | | | | | | | | | | | | | | | | | |
| <input checked="" type="checkbox"/> One month (37 CFR 1.17(a)(1)) | \$120 | \$60 | \$ 60 _____ | | | | | | | | | | | | | | | | | | | | | | | | |
| <input type="checkbox"/> Two months (37 CFR 1.17(a)(2)) | \$450 | \$225 | \$ _____ | | | | | | | | | | | | | | | | | | | | | | | | |
| <input type="checkbox"/> Three months (37 CFR 1.17(a)(3)) | \$1020 | \$510 | \$ _____ | | | | | | | | | | | | | | | | | | | | | | | | |
| <input type="checkbox"/> Four months (37 CFR 1.17(a)(4)) | \$1590 | \$795 | \$ _____ | | | | | | | | | | | | | | | | | | | | | | | | |
| <input type="checkbox"/> Five months (37 CFR 1.17(a)(5)) | \$2160 | \$1080 | \$ _____ | | | | | | | | | | | | | | | | | | | | | | | | |

61142758 v1

| | | | |
|---|---|---|------------------------------------|
| PETITION FOR EXTENSION OF TIME UNDER 37 CFR 1.136(a) FY 2007 <i>(Fees pursuant to the Consolidated Appropriations Act, 2005 (H.R. 4818).)</i> | | Docket Number (Optional) 080379-000100US Client Ref. No.: F/USP81421X Con. | |
| Application Number 11/336,758 | | Filed January 19, 2006 | |
| For DATA STORAGE AND ACCESS SYSTEMS | | | |
| Art Unit 2876 | | Examiner PAIK, Steve S. | |
| This is a request under the provisions of 37 CFR 1.136(a) to extend the period for filing a reply in the above identified application. The requested extension and fee are as follows (check time period desired and enter the appropriate fee below): | | | |
| | | <u>Fee</u> | <u>Small Entity Fee</u> |
| <input checked="" type="checkbox"/> | One month (37 CFR 1.17(a)(1)) | \$120 | \$60 \$ 60 |
| <input type="checkbox"/> | Two months (37 CFR 1.17(a)(2)) | \$450 | \$225 \$ |
| <input type="checkbox"/> | Three months (37 CFR 1.17(a)(3)) | \$1020 | \$510 \$ |
| <input type="checkbox"/> | Four months (37 CFR 1.17(a)(4)) | \$1590 | \$795 \$ |
| <input type="checkbox"/> | Five months (37 CFR 1.17(a)(5)) | \$2160 | \$1080 \$ |
| <input checked="" type="checkbox"/> | Applicant claims small entity status. See 37 CFR 1.27. | | |
| <input type="checkbox"/> | A check in the amount of the fee is enclosed. | | |
| <input type="checkbox"/> | Payment by credit card. Form PTO-2038 is attached. | | |
| <input checked="" type="checkbox"/> | The Director has already been authorized to charge fees in this application to a Deposit Account. | | |
| <input checked="" type="checkbox"/> | The Director is hereby authorized to charge any fees which may be required, or credit any overpayment, to Deposit Account Number <u>20-1430</u> . I have enclosed a duplicate copy of this sheet. | | |
| | WARNING: Information on this form may become public. Credit card information should not be included on this form. Provide credit card information and authorization on PTO-2038. | | |
| I am the | <input type="checkbox"/> | applicant/inventor. | |
| | <input type="checkbox"/> | assignee of record of the entire interest. See 37 CFR 3.71. Statement under 37 CFR 3.73(b) is enclosed (Form PTO/SB/96). | |
| | <input checked="" type="checkbox"/> | attorney or agent of record. Registration Number <u>48,163</u> | |
| | <input type="checkbox"/> | attorney or agent under 37 CFR 1.34. Registration number if acting under 37 CFR 1.34 _____ | |
| |  | _____ Signature | September 4, 2007 Date |
| | Jason D. Lohr, Reg. No. 48,163 | _____ Typed or printed name | (925) 472-5000 Telephone Number |
| NOTE: Signatures of all the inventors or assignees of record of the entire interest or their representative(s) are required. Submit multiple forms if more than one signature is required, see below. | | | |
| <input checked="" type="checkbox"/> | Total of <u>2</u> forms are submitted. | | |



UNITED STATES PATENT AND TRADEMARK OFFICE

UNITED STATES DEPARTMENT OF COMMERCE
United States Patent and Trademark Office
Address: COMMISSIONER FOR PATENTS
P.O. Box 1450
Alexandria, Virginia 22313-1450
www.uspto.gov

| APPLICATION NO. | FILING DATE | FIRST NAMED INVENTOR | ATTORNEY DOCKET NO. | CONFIRMATION NO. |
|-----------------|-------------|----------------------|---------------------|------------------|
| 11/336,758 | 01/19/2006 | Hennen-ard Hulst | 080379-000100US | 3911 |

20350 7590 05/03/2007
TOWNSEND AND TOWNSEND AND CREW, LLP
TWO EMBARCADERO CENTER
EIGHTH FLOOR
SAN FRANCISCO, CA 94111-3834

EXAMINER

PAIK, STEVE S

| ART UNIT | PAPER NUMBER |
|----------|--------------|
| 2876 | |

| MAIL DATE | DELIVERY MODE |
|------------|---------------|
| 05/03/2007 | PAPER |

Please find below and/or attached an Office communication concerning this application or proceeding.

The time period for reply, if any, is set in the attached communication.

| | | | |
|------------------------------|-----------------|--------------|--|
| Office Action Summary | Application No. | Applicant(s) | |
| | 11/336,758 | HULST ET AL. | |
| | Examiner | Art Unit | |
| | Steven S. Paik | 2876 | |

-- The MAILING DATE of this communication appears on the cover sheet with the correspondence address --

Period for Reply

A SHORTENED STATUTORY PERIOD FOR REPLY IS SET TO EXPIRE 3 MONTH(S) OR THIRTY (30) DAYS, WHICHEVER IS LONGER, FROM THE MAILING DATE OF THIS COMMUNICATION.

- Extensions of time may be available under the provisions of 37 CFR 1.136(a). In no event, however, may a reply be timely filed after SIX (6) MONTHS from the mailing date of this communication.
- If NO period for reply is specified above, the maximum statutory period will apply and will expire SIX (6) MONTHS from the mailing date of this communication.
- Failure to reply within the set or extended period for reply will, by statute, cause the application to become ABANDONED (35 U.S.C. § 133). Any reply received by the Office later than three months after the mailing date of this communication, even if timely filed, may reduce any earned patent term adjustment. See 37 CFR 1.704(b).

Status

- 1) Responsive to communication(s) filed on 06 February 2007.
- 2a) This action is **FINAL**. 2b) This action is non-final.
- 3) Since this application is in condition for allowance except for formal matters, prosecution as to the merits is closed in accordance with the practice under *Ex parte Quayle*, 1935 C.D. 11, 453 O.G. 213.

Disposition of Claims

- 4) Claim(s) 22, 23, 35-50 and 59-62 is/are pending in the application.
- 4a) Of the above claim(s) _____ is/are withdrawn from consideration.
- 5) Claim(s) 22, 23 and 35-50 is/are allowed.
- 6) Claim(s) 59-62 is/are rejected.
- 7) Claim(s) _____ is/are objected to.
- 8) Claim(s) _____ are subject to restriction and/or election requirement.

Application Papers

- 9) The specification is objected to by the Examiner.
- 10) The drawing(s) filed on 19 January 2006 is/are: a) accepted or b) objected to by the Examiner.
 Applicant may not request that any objection to the drawing(s) be held in abeyance. See 37 CFR 1.85(a).
 Replacement drawing sheet(s) including the correction is required if the drawing(s) is objected to. See 37 CFR 1.121(d).
- 11) The oath or declaration is objected to by the Examiner. Note the attached Office Action or form PTO-152.

Priority under 35 U.S.C. § 119

- 12) Acknowledgment is made of a claim for foreign priority under 35 U.S.C. § 119(a)-(d) or (f).
- a) All b) Some * c) None of:
1. Certified copies of the priority documents have been received.
2. Certified copies of the priority documents have been received in Application No. 10/111,716.
3. Copies of the certified copies of the priority documents have been received in this National Stage application from the International Bureau (PCT Rule 17.2(a)).
- * See the attached detailed Office action for a list of the certified copies not received.

Attachment(s)

- | | |
|--|---|
| 1) <input type="checkbox"/> Notice of References Cited (PTO-892) | 4) <input type="checkbox"/> Interview Summary (PTO-413) Paper No(s)/Mail Date. _____ |
| 2) <input type="checkbox"/> Notice of Draftsperson's Patent Drawing Review (PTO-948) | 5) <input type="checkbox"/> Notice of Informal Patent Application |
| 3) <input type="checkbox"/> Information Disclosure Statement(s) (PTO/SB/08) Paper No(s)/Mail Date _____ | 6) <input type="checkbox"/> Other: _____ |

DETAILED ACTION

Response to Amendment

1. Receipt is acknowledged of the Amendment filed February 6, 2007. The amendment amends claims 22, 35, 40, 41, 44, 46, and 49.

Oath/Declaration

2. The oath or declaration is defective. A new oath or declaration in compliance with 37 CFR 1.67(a) identifying this application by application number and filing date is required. See MPEP §§ 602.01 and 602.02.

The oath or declaration is defective because:

The oath or declaration contains incorrect application number and filing date.

Claim Rejections - 35 USC § 102

3. The following is a quotation of the appropriate paragraphs of 35 U.S.C. 102 that form the basis for the rejections under this section made in this Office action:

A person shall be entitled to a patent unless --

(b) the invention was patented or described in a printed publication in this or a foreign country or in public use or on sale in this country, more than one year prior to the date of application for patent in the United States.

4. Claims 59-62 are rejected under 35 U.S.C. 102(b) as being anticipated by Hiroya et al. (US 5,754,654, cited by the applicant).

Re claim 59, Hiroya et al. disclose a method and a system comprising an electronic ticket storage device (2), a terminal device (3), a communication line (4), and an electronic ticket vending and refunding device (1). The electronic ticket storage device further comprises IC chip having a storage unit (31) comprised of various readable/writable storage units (32-36), an I/O interface (37), and a central processing unit (38). The method further comprising:

retrieving use status data from the data carrier indicating past use of the stored data (electronic ticket);

retrieving use rules from the data carrier (2);

evaluating the use status data (valid/invalid) using the use rules to determine whether access to data stored on the carrier is permitted; and

permitting access to the data on the data carrier dependent on the result of said evaluating (Fig. 12 and col. 19, line 4 – col. 21, line 45).

Re claim 60, Hiroya et al. disclose the method and the system as recited in rejected claim 59 stated above, further writing updated use status data (1190 in Fig. 12) to the carrier after an access attempt.

Re claim 61, Hiroya et al. disclose the method and the system as recited in rejected claim 60 stated above, wherein said use rules permit partial access to a data item and wherein said writing writes a record of what part of the data item has been accessed when only part of the data item has been accessed (The electronic ticket storage area can store more than one ticket information and only a portion of the ticket information can be accessed one at a time.)

Re claim 62, Hiroya et al. disclose the method and the system as recited in rejected claim 59 stated above, further comprising:

inputting a user access data (electronic ticket information data);

selecting the use rules (electronic ticket return/refund rule) dependent upon the user access data.

Allowable Subject Matter

5. Claims 22, 23, and 35-50 are allowed.

6. The following is a statement of reasons for the indication of allowable subject matter: the amended claims have overcome the teachings of prior art. The Horoya reference does not disclose use status data stored separately from associated content data. Horoya also fails to teach writing separate access rules to an electronic ticket storage device, particularly where the access rules contain conditions that are dependent upon an amount of payment associated with the payment data forwarded to the payment validation system.

Response to Arguments

7. The examiner respectfully points out that the response filed on February 6, 2007 does not address the issues discussed in the previous office action. For example, the applicant has not provided any response regarding the objection to the Oath/Declaration. There is also no response about the rejection of claims 59-62. Thus, claims 59-62 remain rejected.

Conclusion

8. Applicant's amendment necessitated the new ground(s) of rejection presented in this Office action. Accordingly, **THIS ACTION IS MADE FINAL**. See MPEP § 706.07(a). Applicant is reminded of the extension of time policy as set forth in 37 CFR 1.136(a).

A shortened statutory period for reply to this final action is set to expire THREE MONTHS from the mailing date of this action. In the event a first reply is filed within TWO MONTHS of the mailing date of this final action and the advisory action is not mailed until after the end of the THREE-MONTH shortened statutory period, then the shortened statutory period will expire on the date the advisory action is mailed, and any extension fee pursuant to 37 CFR 1.136(a) will be calculated from the mailing date of the advisory action. In no event,

Application/Control Number: 11/336,758
Art Unit: 2876

Page 5

however, will the statutory period for reply expire later than SIX MONTHS from the date of this final action.

Any inquiry concerning this communication or earlier communications from the examiner should be directed to Steven S. Paik whose telephone number is 571-272-2404. The examiner can normally be reached on Monday - Friday 6:30a-3:00p (Maxi-Flex*).

If attempts to reach the examiner by telephone are unsuccessful, the examiner's supervisor, Michael G. Lee can be reached on 571-272-2398. The fax phone number for the organization where this application or proceeding is assigned is 571-273-8300.

Information regarding the status of an application may be obtained from the Patent Application Information Retrieval (PAIR) system. Status information for published applications may be obtained from either Private PAIR or Public PAIR. Status information for unpublished applications is available through Private PAIR only. For more information about the PAIR system, see <http://pair-direct.uspto.gov>. Should you have questions on access to the Private PAIR system, contact the Electronic Business Center (EBC) at 866-217-9197 (toll-free). If you would like assistance from a USPTO Customer Service Representative or access to the automated information system, call 800-786-9199 (IN USA OR CANADA) or 571-272-1000.

Steven S. Paik
Primary Examiner
(steve.paik@uspto.gov)
Art Unit 2876

ssp

Index of Claims



Application/Control No.

11/336,758

Examiner

Steven S. Paik

Applicant(s)/Patent under Reexamination

HULST ET AL.

Art Unit

2876

| | |
|---|----------|
| ✓ | Rejected |
| = | Allowed |

| | |
|---|--------------------------------|
| - | (Through numeral) Cancelled |
| + | Restricted |

| | |
|---|--------------|
| N | Non-Elected |
| I | Interference |

| | |
|---|----------|
| A | Appeal |
| O | Objected |

| Claim | Date | | |
|-------|----------|---------|--|
| Final | Original | 4/29/07 | |
| 1 | | | |
| 2 | | | |
| 3 | | | |
| 4 | | | |
| 5 | | | |
| 6 | | | |
| 7 | | | |
| 8 | | | |
| 9 | | | |
| 10 | | | |
| 11 | | | |
| 12 | | | |
| 13 | | | |
| 14 | | | |
| 15 | | | |
| 16 | | | |
| 17 | | | |
| 18 | | | |
| 19 | | | |
| 20 | | | |
| 21 | | | |
| 22 | | 11 | |
| 23 | | 11 | |
| 24 | | | |
| 25 | | | |
| 26 | | | |
| 27 | | | |
| 28 | | | |
| 29 | | | |
| 30 | | | |
| 31 | | | |
| 32 | | | |
| 33 | | | |
| 34 | | | |
| 35 | | 11 | |
| 36 | | | |
| 37 | | | |
| 38 | | | |
| 39 | | | |
| 40 | | | |
| 41 | | | |
| 42 | | | |
| 43 | | | |
| 44 | | | |
| 45 | | | |
| 46 | | | |
| 47 | | | |
| 48 | | | |
| 49 | | | |
| 50 | | | |

| Claim | Date | | |
|-------|----------|---------|--|
| Final | Original | 4/29/07 | |
| 51 | | | |
| 52 | | | |
| 53 | | | |
| 54 | | | |
| 55 | | | |
| 56 | | | |
| 57 | | | |
| 58 | | | |
| 59 | | ✓ | |
| 60 | | ✓ | |
| 61 | | ✓ | |
| 62 | | ✓ | |
| 63 | | | |
| 64 | | | |
| 65 | | | |
| 66 | | | |
| 67 | | | |
| 68 | | | |
| 69 | | | |
| 70 | | | |
| 71 | | | |
| 72 | | | |
| 73 | | | |
| 74 | | | |
| 75 | | | |
| 76 | | | |
| 77 | | | |
| 78 | | | |
| 79 | | | |
| 80 | | | |
| 81 | | | |
| 82 | | | |
| 83 | | | |
| 84 | | | |
| 85 | | | |
| 86 | | | |
| 87 | | | |
| 88 | | | |
| 89 | | | |
| 90 | | | |
| 91 | | | |
| 92 | | | |
| 93 | | | |
| 94 | | | |
| 95 | | | |
| 96 | | | |
| 97 | | | |
| 98 | | | |
| 99 | | | |
| 100 | | | |

| Claim | Date | | |
|-------|----------|--|--|
| Final | Original | | |
| 101 | | | |
| 102 | | | |
| 103 | | | |
| 104 | | | |
| 105 | | | |
| 106 | | | |
| 107 | | | |
| 108 | | | |
| 109 | | | |
| 110 | | | |
| 111 | | | |
| 112 | | | |
| 113 | | | |
| 114 | | | |
| 115 | | | |
| 116 | | | |
| 117 | | | |
| 118 | | | |
| 119 | | | |
| 120 | | | |
| 121 | | | |
| 122 | | | |
| 123 | | | |
| 124 | | | |
| 125 | | | |
| 126 | | | |
| 127 | | | |
| 128 | | | |
| 129 | | | |
| 130 | | | |
| 131 | | | |
| 132 | | | |
| 133 | | | |
| 134 | | | |
| 135 | | | |
| 136 | | | |
| 137 | | | |
| 138 | | | |
| 139 | | | |
| 140 | | | |
| 141 | | | |
| 142 | | | |
| 143 | | | |
| 144 | | | |
| 145 | | | |
| 146 | | | |
| 147 | | | |
| 148 | | | |
| 149 | | | |
| 150 | | | |

Search Notes



Application/Control No.

11/336,758

Examiner

Steven S. Paik

Applicant(s)/Patent under Reexamination

HULST ET AL.

Art Unit

2876

SEARCHED

| Class | Subclass | Date | Examiner |
|---------|----------|-----------|----------|
| 235 | 380 | | |
| | 382 | | |
| | 492 | | |
| updated | | 4/29/2007 | SSP |
| | | | |
| | | | |
| | | | |
| | | | |
| | | | |
| | | | |
| | | | |
| | | | |
| | | | |
| | | | |
| | | | |
| | | | |
| | | | |

**SEARCH NOTES
(INCLUDING SEARCH STRATEGY)**

| | DATE | EXMR |
|---|-----------|------|
| EAST | | |
| Text search combined with 235/\$7.ccls. | | |
| Reviewed 10/111,716 | | |
| updated | 4/29/2007 | SSP |
| | | |
| | | |
| | | |
| | | |
| | | |
| | | |
| | | |
| | | |
| | | |
| | | |
| | | |
| | | |
| | | |
| | | |

INTERFERENCE SEARCHED

| Class | Subclass | Date | Examiner |
|-------|----------|------|----------|
| | | | |
| | | | |
| | | | |
| | | | |
| | | | |
| | | | |
| | | | |
| | | | |
| | | | |
| | | | |
| | | | |
| | | | |
| | | | |
| | | | |
| | | | |
| | | | |

I hereby certify that this correspondence is being filed via
EFS-Web with the United States Patent and Trademark Office
on February 6, 2007

PATENT
Attorney Docket No.: 080379-000100US
Client Ref. No.: F/USP81421X Con.

TOWNSEND and TOWNSEND and CREW LLP

By: Shirley Hall

IN THE UNITED STATES PATENT AND TRADEMARK OFFICE

In re application of:

Herman-ard HULST
Patrick SANDOR

Application No.: 11/336,758

Filed: January 19, 2006

For: DATA STORAGE AND ACCESS
SYSTEMS

Customer No.: 20350

Confirmation No. 3911

Examiner: PAIK, Steve S.

Technology Center/Art Unit: 2876

AMENDMENT

Mail Stop Amendment
Commissioner for Patents
P.O. Box 1450
Alexandria, VA 22313-1450

Sir:

In response to the Office Action mailed November 6, 2006, please enter the
following amendments and remarks:

Amendments to the Claims are reflected in the listing of claims which begins on page 2 of this
paper.

Remarks/Arguments begin on page 7 of this paper.

Amendments to the Claims:

This listing of claims will replace all prior versions, and listings of claims in the application:

Listing of Claims:

Claims 1-21. (Canceled)

22. (Currently Amended) A method of controlling access to content data on a data carrier, the data carrier comprising non-volatile data memory storing content memory and non-volatile parameter memory storing use status data and use rules, the method comprising:

receiving a data access request from a user for at least one content item of the content data stored in the non-volatile data memory;

reading the use status data and use rules from the parameter memory that pertain to use of the at least one requested content item; and

evaluating the use status data using the use rules to determine whether access to the stored data at least one requested content item stored in the content memory is permitted; and

[[.]]

displaying to the user whether access is permitted for each of the at least one requested content item stored in the non-volatile data memory.

23. (Original) A method as claimed in claim 22 wherein said parameter memory further stores payment data and further comprising selecting a said use rule dependent upon said payment data.

Claims 24-34. (Canceled)

35. (Currently Amended) A data access terminal for retrieving data from a data supplier and providing the retrieved data to a data carrier, the terminal comprising:

a first interface for communicating with the data supplier;

a data carrier interface for interfacing with the data carrier;

a program store storing code; and implementable by a processor; and
a processor [[,]] coupled to the first interface, the data carrier interface, and [[to]]
the program store for implementing the stored code, the code comprising:
code to read payment data from the data carrier and to forward the payment data
to a payment validation system;
code to receive payment validation data from the payment validation system;
code responsive to the payment validation data to retrieve data from the data
supplier and to write the retrieved data into the data carrier; and
code responsive to the payment validation data to receive at least one access rule
from the data supplier and to write the at least one access rule into the data carrier, the at least
one access rule specifying at least one condition for accessing the retrieved data written into the
data carrier, the at least one condition being dependent upon the amount of payment associated
with the payment data forwarded to the payment validation system.

36. (Original) A data access terminal as claimed in claim 35 further
comprising code to transmit at least a portion of the payment validation data to the data supplier
or to a destination received from the data supplier.

37. (Previously Presented) A data access terminal as claimed in claim 35
further comprising code to retrieve from the data supplier and output to a user stored data
identifier data and associated value data and use rule data for a data item available from the data
supplier.

38. (Original) A data access terminal as claimed in claim 37 further
comprising code to write use rule data for a data item into the data carrier with the associated
data item.

39. (Previously Presented) A data access terminal as claimed in claim 37
further comprising code to read a stored value from the data carrier, code to compare said stored
value with said value data; and code to provide a modified output to a user of one or more of said

stored data identifier data, said value data and said use rule data, in response to a result of the comparison.

40. (Currently Amended) A data access terminal according to claim 35 further comprising code for user input of access control data, code to output the access control data to the data carrier, and code to receive access permission data ~~from the card, and code to~~ and output data to the user in response to the received access permission data.

41. (Currently Amended) A data access terminal as claimed in claim 40 further comprising code to output a data erasure ~~warning~~ warning in response to the received access permission data.

42. (Previously Presented) A data access terminal according to claim 35 further comprising code to read reward data from the data carrier and to write modified reward data to the data carrier in response to said retrieval of data from the data supplier.

43. (Previously Presented) A data access terminal according to claim 35 further comprising:

- code to read identity data from the data carrier;
- code to transmit the identity data to the data supplier;
- code to receive user characterizing data from the data supplier;
- code to retrieve supplementary data in response to said characterizing data; and
- code to output the supplementary data.

44. (Currently Amended) A data access terminal according to claim 35 further comprising a cash input device coupled to the processor, to provide cash input value data; and code to update payment data in the data carrier, in accordance with the cash input value data.

45. (Previously Presented) A data access terminal according to claim 35 integrated with a mobile communication device, a personal computer, an audio/video player, and/or a cable or satellite television interface device.

46. (Currently Amended) A method of providing data from a data supplier to a data carrier, the method comprising:

reading payment data from the data carrier;

forwarding the payment data to a payment validation system;

retrieving data from the data supplier; and

writing the retrieved data into the ~~date~~ data carrier;

receiving at least one access rule from the data supplier; and

writing the at least one access rule into the data carrier, the at least one access rule specifying at least one condition for accessing the retrieved data written into the data carrier, the at least one condition being dependent upon the amount of payment associated with the payment data forwarded to the payment validation system.

47. (Original) A method of providing data from a data supplier according to claim 46 further comprising:

receiving payment validation data from the payment validation system; and

transmitting at least a portion of the payment validation data to the data supplier.

48. (Original) A method of providing data as claimed in claim 47, wherein the payment validation system comprises a payment processor at the data supplier.

49. (Currently Amended) A method of providing data as claimed in claim 46, further comprising:

retrieving from the data supplier a stored data item identifier and associated value data ~~and use rule data~~; and

writing ~~use rule data~~ the stored data item identifier and associated value data for the data item into the data carrier.

50. (Previously Presented) A method of providing data as claimed in claim 48, further comprising:

reading a stored value from the data carrier;

comparing the stored value with said value data; and
outputting to a user information indicating the result of said comparing.

Claims 51-58. (Canceled)

59. (Original) A method of controlling access to data from a data carrier,
comprising:
retrieving use status data from the data carrier indicating past use of the stored
data;
retrieving use rules from the data carrier;
evaluating the use status data using the use rules to determine whether access to
data stored on the carrier is permitted; and
permitting access to the data on the data carrier dependent on the result of said
evaluating.

60. (Original) A method of controlling access according to claim 59, further
comprising:
writing updated use status data to the carrier after an access attempt.

61. (Original) A method of controlling access according to claim 60, wherein
said use rules permit partial access to a data item and wherein said writing writes a record of
what part of the data item has been accessed when only part of the data item has been accessed.

62. (Previously Presented) A method of controlling access according to claim
59, further comprising:

inputting a user access data;
selecting the use rules dependent upon the user access data.

Claims 63-74. (Canceled)

REMARKS/ARGUMENTS

This Amendment is in response to the Office Action mailed November 6, 2006. Claims 22, 23, 35-50, and 59-62 were pending in the present application. This Amendment amends claims 22, 35, 40, 41, 44, 46, and 49, without adding or canceling any claims, leaving pending in the application claims 22, 23, 35-50, and 59-62. Reconsideration of the rejected claims is respectfully requested.

I. Priority and Oath/Declaration

It is respectfully submitted that is application is a continuation of, and claims priority to, U.S. Patent Application Serial No. 10/111,716 (which in turn claims priority to the UK application). This claim of priority was submitted with the application as filed and can be verified through the PAIR system. The Office Action states on page 2 that applicant has not filed a certified copy of the foreign application in the present application. It is respectfully submitted that MPEP §201.14(b) states "Where the benefit of a foreign filing date based on a foreign application is claimed in a later filed application (i.e., continuation, continuation-in-part, division) or in a reissue application and a certified copy of the foreign application as filed, has been filed in a parent or related application, it is not necessary to file an additional certified copy in the later application." As such, it is not believed that an additional certified copy is necessary.

Further, the Office Action on page 2 states that the oath or declaration is defective for identifying an incorrect application number and filing date. It is respectfully submitted that the oath or declaration is not defective as it identifies the application number and filing date of the parent application, of which this application is a continuation. 37 CFR §1.63 states that a "newly executed oath or declaration is not required under §1.51(b)(2) and §1.53(f) in a continuation or divisional application." Further, MPEP §602.05(a) states that a "continuation or divisional application filed under 37 CFR 1.53(b) (other than a continuation-in-part (CIP)) may be filed with a copy of the oath or declaration from the prior nonprovisional application." As such, it is believed that the oath or declaration is not defective as it is a copy of what was filed in the parent application.

Applicants therefore respectfully request that the objections to the priority claims and the oath/declaration be withdrawn. If such belief on Applicants' part is not accurate, Applicants respectfully request that the Examiner contact the undersigned attorney to ensure that the present response is not considered to be non-responsive and does not result in abandonment of the present application.

II. Objection to the Claims

Claims 41 and 44 are objected to for including informalities, particularly a typographical error for the term "warning" and the inadvertent omission of a period at the end of a claim. Applicants appreciate the Examiner's careful attention to detail, and have amended these claims appropriately. It is noted that Applicants' copy of claim 44 included a period at the end, but due to copying and other such issues the period may not have appeared to be included in the claim so Applicants have thus amended the claim to add a period in order to be responsive. It is respectfully requested that if such a period is found to have been included in the claim, that this amendment not be rejected as being non-compliant for reciting an incorrect status identifier and/or not amending the claim. As the claims should no longer contain the objectionable informalities, Applicants respectfully request that the objections to these claims be withdrawn.

III. Rejection under 35 U.S.C. §112

Claims 35 and 40 are rejected under 35 U.S.C. §112, second paragraph, as being indefinite for failing to particularly point out and distinctly claim the subject matter which applicant regards as the invention. In particular, these claims are rejected for lacking proper antecedent basis for each term recited therein. These claims as amended should include proper antecedent basis for each term recited therein. Applicants therefore respectfully request that the rejection with respect to claims 35 and 40 be withdrawn.

IV. Rejection under 35 U.S.C. §102

Claims 22, 23, 35-50, and 59-62 are rejected under 35 U.S.C. §102(b) as being anticipated by *Hiroya* (U.S. Patent No. 5,754,654). Applicants respectfully submit that *Hiroya* does not disclose each element of these claims.

For example, Applicants' claim 22 as amended recites a method of controlling access to content data on a data carrier, the data carrier comprising non-volatile data memory storing content memory and non-volatile parameter memory storing use status data and use rules, the method comprising:

receiving a data access request from a user for at least one content item of the content data stored in the non-volatile data memory;
reading the use status data and use rules from the parameter memory that pertain to use of the at least one requested content item;
evaluating the use status data using the use rules to determine whether access to the at least one requested content item stored in the content memory is permitted; and
displaying to the user whether access is permitted for each of the at least one requested content item stored in the non-volatile data memory

(*emphasis added*). Such limitations are not disclosed by *Hiroya*.

Hiroya discloses an electronic ticket vending and refunding system wherein a ticket purchaser can purchase a ticket to an event, etc., through a man-machine interface, whereby the ticket information is transferred to an electronic ticket storage device (col. 11, lines 36-49). In this system, the electronic ticket is stored in the electronic ticket storage device and includes ticket information data and an electronic signature (col. 15, lines 62-67), and the ticket can be redeemed by decrypting the electronic signature and ticket information data so that a man-machine interface can verify the validity of the electronic ticket (col. 23, line 64-col. 24, line 18). *Hiroya* does not disclose status data and use rules stored in a parameter memory, wherein the use rules stored on the non-volatile memory are used to analyze the use status data stored on the non-volatile memory to determine whether access to separately-stored requested content is permitted as required in Applicants' claim 22 as amended. *Hiroya* discloses that electronic ticket information itself includes both the ticket data and the validity data, and that the electronic ticket information must be decrypted to be validated. *Hiroya* does not disclose use status data stored separately from associated content data, and since ticket data is either valid or not valid in and of itself and does not include separate use data, *Hiroya* does not suggest or provide motivation to

store use data as recited in claim 22. Further, as *Hiroya* discloses only ticket information that can be redeemed, and not content that can be accessed multiple times, partially used, used at different times, etc., such that there would be no motivation to include use data with the device of *Hiroya*. As *Hiroya* does not disclose such limitations, *Hiroya* cannot anticipate Applicants' claim 22 or the claims that depend therefrom.

Applicants' claim 35 recites a data access terminal for retrieving data from a data supplier and providing the retrieved data to a data carrier, comprising:

- a first interface for communicating with the data supplier;
- a data carrier interface for interfacing with the data carrier;
- a program store storing code; and
- a processor coupled to the first interface, the data carrier interface, and the program store for implementing the stored code, the code comprising:
 - code to read payment data from the data carrier and to forward the payment data to a payment validation system;
 - code to receive payment validation data from the payment validation system;
 - code responsive to the payment validation data to retrieve data from the data supplier and to write the retrieved data into the data carrier; and
 - code responsive to the payment validation data to receive at least one access rule from the data supplier and to write the at least one access rule into the data carrier, the at least one access rule specifying at least one condition for accessing the retrieved data written into the data carrier, the at least one condition being dependent upon the amount of payment associated with the payment data forwarded to the payment validation system

(*emphasis added*). Such limitations also are not anticipated by *Hiroya*, as *Hiroya* does not disclose writing separate access rules to an electronic ticket storage device, particularly where the access rules contain conditions that are dependent upon an amount of payment. As a ticket is either purchased or not purchased, and thus validly present or not present on the device, there is no need to store access rules including conditions based on an amount of payment. As such, *Hiroya* also does not anticipate Applicants' claim 35 or the claims that depend therefrom.

The other independent claims recite limitations that are not disclosed by *Hiroya*, for reasons including those discussed above, such that these claims and the claims that depend therefrom also cannot be anticipated by *Hiroya*. Applicants therefore respectfully request that the rejections with respect to claims 22, 23, 35-50, and 59-62 be withdrawn.

Appl. No. 11/336,758
Amdt. dated February 6, 2007
Reply to Office Action of November 6, 2006

PATENT

V. Amendment to the Claims

Unless otherwise specified, amendments to the claims are made for purposes of clarity, and are not intended to alter the scope of the claims or limit any equivalents thereof. The amendments are supported by the specification and do not add new matter.

CONCLUSION

In view of the foregoing, Applicants believe all claims now pending in this Application are in condition for allowance. The issuance of a formal Notice of Allowance at an early date is respectfully requested.

If the Examiner believes a telephone conference would expedite prosecution of this application, please telephone the undersigned at .

Respectfully submitted,



Jason D. Lohr
Reg. No. 48,163

TOWNSEND and TOWNSEND and CREW LLP
Two Embarcadero Center, Eighth Floor
San Francisco, California 94111-3834
Tel: 925-472-5000
Fax: 415-576-0300
Attachments
JDL:slh
60972471 v1

Electronic Acknowledgement Receipt

| | |
|---|---------------------------------|
| EFS ID: | 1495559 |
| Application Number: | 11336758 |
| International Application Number: | |
| Confirmation Number: | 3911 |
| Title of Invention: | Data storage and access systems |
| First Named Inventor/Applicant Name: | Hermen-ard Hulst |
| Customer Number: | 20350 |
| Filer: | Jason Donald Lohr/Sherri Hale |
| Filer Authorized By: | Jason Donald Lohr |
| Attorney Docket Number: | 080379-000100US |
| Receipt Date: | 06-FEB-2007 |
| Filing Date: | 19-JAN-2006 |
| Time Stamp: | 17:23:43 |
| Application Type: | Utility |

Payment information:

| | |
|------------------------|----|
| Submitted with Payment | no |
|------------------------|----|

File Listing:

| Document Number | Document Description | File Name | File Size(Bytes) | Multi Part /.zip | Pages (if appl.) |
|-----------------|---------------------------------------|-------------------------------|------------------|------------------|------------------|
| 1 | Amendment - After Non-Final Rejection | 080379_000100US_Amendment.pdf | 463898 | no | 11 |

Warnings:

| | |
|---|--------|
| Information: | |
| Total Files Size (in bytes): | 463898 |
| <p>This Acknowledgement Receipt evidences receipt on the noted date by the USPTO of the indicated documents, characterized by the applicant, and including page counts, where applicable. It serves as evidence of receipt similar to a Post Card, as described in MPEP 503.</p> <p><u>New Applications Under 35 U.S.C. 111</u> If a new application is being filed and the application includes the necessary components for a filing date (see 37 CFR 1.53(b)-(d) and MPEP 506), a Filing Receipt (37 CFR 1.54) will be issued in due course and the date shown on this Acknowledgement Receipt will establish the filing date of the application.</p> <p><u>National Stage of an International Application under 35 U.S.C. 371</u> If a timely submission to enter the national stage of an international application is compliant with the conditions of 35 U.S.C. 371 and other applicable requirements a Form PCT/DO/EO/903 indicating acceptance of the application as a national stage submission under 35 U.S.C. 371 will be issued in addition to the Filing Receipt, in due course.</p> <p><u>New International Application Filed with the USPTO as a Receiving Office</u> If a new international application is being filed and the international application includes the necessary components for an international filing date (see PCT Article 11 and MPEP 1810), a Notification of the International Application Number and of the International Filing Date (Form PCT/RO/105) will be issued in due course, subject to prescriptions concerning national security, and the date shown on this Acknowledgement Receipt will establish the international filing date of the application.</p> | |

Under the Paperwork Reduction Act of 1995, no persons are required to respond to a collection of information unless it displays a valid OMB control number.

| PATENT APPLICATION FEE DETERMINATION RECORD | | | | | Application or Docket Number 11/336,758 | |
|---|---|------------------------------------|---------------|------------|---|------------|
| Substitute for Form PTO-875 | | | | | | |
| APPLICATION AS FILED - PART I | | | SMALL ENTITY | | OR OTHER THAN SMALL ENTITY | |
| (Column 1) | (Column 2) | (Column 3) | (Column 4) | (Column 5) | (Column 6) | (Column 7) |
| FOR: | NUMBER FILED | NUMBER EXTRA | RATE (\$) | FEE (\$) | RATE (\$) | FEE (\$) |
| BASIC FEE (37 CFR 1.18(a), (b), or (c)) | | | | | | |
| SEARCH FEE (37 CFR 1.18(k), (l), or (m)) | | | | | | |
| EXAMINATION FEE (37 CFR 1.18(c), (p), or (q)) | | | | | | |
| TOTAL CLAIMS (37 CFR 1.18(f)) | minus 20 = | | X = | | X = | |
| INDEPENDENT CLAIMS (37 CFR 1.18(h)) | minus 3 = | | X = | | X = | |
| APPLICATION SIZE FEE (37 CFR 1.16(s)) | If the specification and drawings exceed 100 sheets of paper, the application size fee due is \$250 (\$125 for small entity) for each additional 50 sheets or fraction thereof. See 35 U.S.C. 41(a)(1)(G) and 37 CFR 1.16(s). | | | | | |
| MULTIPLE DEPENDENT CLAIM PRESENT (37 CFR 1.16(j)) | | | | | | |
| * If the difference in column 1 is less than zero, enter "0" in column 2. | | | | | | |
| APPLICATION AS AMENDED - PART II | | | SMALL ENTITY | | OR OTHER THAN SMALL ENTITY | |
| (Column 1) | (Column 2) | (Column 3) | (Column 4) | (Column 5) | (Column 6) | (Column 7) |
| AMENDMENT A | CLAIMS REMAINING AFTER AMENDMENT | HIGHEST NUMBER PREVIOUSLY PAID FOR | PRESENT EXTRA | RATE (\$) | ADDITIONAL FEE (\$) | RATE (\$) |
| Total (37 CFR 1.16(i)) | 22 | Minus ** 74 | = / | X 25 = | | X 50 = |
| Independent (37 CFR 1.16(h)) | 4 | Minus *** 16 | = / | X 100 = | | X 200 = |
| Application Size Fee (37 CFR 1.16(s)) | | | | | | |
| FIRST PRESENTATION OF MULTIPLE DEPENDENT CLAIM (37 CFR 1.16(j)) | | | | | | |
| TOTAL ADD'L FEE | | | | | | |
| (Column 1) | (Column 2) | (Column 3) | (Column 4) | (Column 5) | (Column 6) | (Column 7) |
| AMENDMENT B | CLAIMS REMAINING AFTER AMENDMENT | HIGHEST NUMBER PREVIOUSLY PAID FOR | PRESENT EXTRA | RATE (\$) | ADDITIONAL FEE (\$) | RATE (\$) |
| Total (37 CFR 1.16(i)) | | Minus ** | = | X = | | X = |
| Independent (37 CFR 1.16(h)) | | Minus *** | = | X = | | X = |
| Application Size Fee (37 CFR 1.16(s)) | | | | | | |
| FIRST PRESENTATION OF MULTIPLE DEPENDENT CLAIM (37 CFR 1.16(j)) | | | | | | |
| TOTAL ADD'L FEE | | | | | | |
| * If the entry in column 1 is less than the entry in column 2, write "0" in column 3. | | | | | | |
| ** If the "Highest Number Previously Paid For" IN THIS SPACE is less than 20, enter "20". | | | | | | |
| *** If the "Highest Number Previously Paid For" IN THIS SPACE is less than 3, enter "3". | | | | | | |
| The "Highest Number Previously Paid For" (Total or Independent) is the highest number found in the appropriate box in column 1. | | | | | | |

This collection of information is required by 37 CFR 1.16. The information is required to obtain or retain a benefit by the public which is to file (and by the USPTO to process) an application. Confidentiality is governed by 35 U.S.C. 122 and 37 CFR 1.14. This collection is estimated to take 12 minutes to complete, including gathering, preparing, and submitting the completed application form to the USPTO. Time will vary depending upon the individual case. Any comments on the amount of time you require to complete this form and/or suggestions for reducing this burden, should be sent to the Chief Information Officer, U.S. Patent and Trademark Office, U.S. Department of Commerce, P.O. Box 1450, Alexandria, VA 22313-1450. DO NOT SEND FEES OR COMPLETED FORMS TO THIS ADDRESS. SEND TO: Commissioner for Patents, P.O. Box 1450, Alexandria, VA 22313-1450.

If you need assistance in completing the form, call 1-800-PTO-9199 and select option 2.



UNITED STATES PATENT AND TRADEMARK OFFICE

UNITED STATES DEPARTMENT OF COMMERCE
United States Patent and Trademark Office
Address: COMMISSIONER FOR PATENTS
P.O. Box 1450
Alexandria, Virginia 22313-1450
www.uspto.gov

| APPLICATION NO. | FILING DATE | FIRST NAMED INVENTOR | ATTORNEY DOCKET NO. | CONFIRMATION NO. |
|-----------------|-------------|----------------------|---------------------|------------------|
|-----------------|-------------|----------------------|---------------------|------------------|

| | | | | |
|------------|------------|------------------|-----------------|------|
| 11/336,758 | 01/19/2006 | Hermen-ard Hulst | 080379-000100US | 3911 |
|------------|------------|------------------|-----------------|------|

| | | | | |
|-------|------|------------|--|--|
| 20350 | 7590 | 11/06/2006 | | |
|-------|------|------------|--|--|

TOWNSEND AND TOWNSEND AND CREW, LLP
TWO EMBARCADERO CENTER
EIGHTH FLOOR
SAN FRANCISCO, CA 94111-3834

EXAMINER

PAIK, STEVE S

| ART UNIT | PAPER NUMBER |
|----------|--------------|
|----------|--------------|

2876

DATE MAILED: 11/06/2006

Please find below and/or attached an Office communication concerning this application or proceeding.

dm

| | | | |
|------------------------------|-------------------------------|------------------------------|--|
| Office Action Summary | Application No. 11/336,758 | Applicant(s) HULST ET AL. | |
| | Examiner Steven S. Paik | Art Unit 2876 | |

-- The MAILING DATE of this communication appears on the cover sheet with the correspondence address --
Period for Reply

A SHORTENED STATUTORY PERIOD FOR REPLY IS SET TO EXPIRE 3 MONTH(S) OR THIRTY (30) DAYS, WHICHEVER IS LONGER, FROM THE MAILING DATE OF THIS COMMUNICATION.

- Extensions of time may be available under the provisions of 37 CFR 1.136(a). In no event, however, may a reply be timely filed after SIX (6) MONTHS from the mailing date of this communication.
- If NO period for reply is specified above, the maximum statutory period will apply and will expire SIX (6) MONTHS from the mailing date of this communication.
- Failure to reply within the set or extended period for reply will, by statute, cause the application to become ABANDONED (35 U.S.C. § 133). Any reply received by the Office later than three months after the mailing date of this communication, even if timely filed, may reduce any earned patent term adjustment. See 37 CFR 1.704(b).

Status

- 1) Responsive to communication(s) filed on 29 September 2006.
- 2a) This action is FINAL.
- 2b) This action is non-final.
- 3) Since this application is in condition for allowance except for formal matters, prosecution as to the merits is closed in accordance with the practice under *Ex parte Quayle*, 1935 C.D. 11, 453 O.G. 213.

Disposition of Claims

- 4) Claim(s) 22, 23, 35-50 and 59-62 is/are pending in the application.
 - 4a) Of the above claim(s) _____ is/are withdrawn from consideration.
- 5) Claim(s) _____ is/are allowed.
- 6) Claim(s) 22, 23, 35-50, and 59-62 is/are rejected.
- 7) Claim(s) _____ is/are objected to.
- 8) Claim(s) _____ are subject to restriction and/or election requirement.

Application Papers

- 9) The specification is objected to by the Examiner.
- 10) The drawing(s) filed on 19 January 2006 is/are: a) accepted or b) objected to by the Examiner. Applicant may not request that any objection to the drawing(s) be held in abeyance. See 37 CFR 1.85(a). Replacement drawing sheet(s) including the correction is required if the drawing(s) is objected to. See 37 CFR 1.121(d).
- 11) The oath or declaration is objected to by the Examiner. Note the attached Office Action or form PTO-152.

Priority under 35 U.S.C. § 119

- 12) Acknowledgment is made of a claim for foreign priority under 35 U.S.C. § 119(a)-(d) or (f).
 - a) All b) Some * c) None of:
 - 1. Certified copies of the priority documents have been received.
 - 2. Certified copies of the priority documents have been received in Application No. _____.
 - 3. Copies of the certified copies of the priority documents have been received in this National Stage application from the International Bureau (PCT Rule 17.2(a)).
- * See the attached detailed Office action for a list of the certified copies not received.

Attachment(s)

- 1) Notice of References Cited (PTO-892)
- 2) Notice of Draftsperson's Patent Drawing Review (PTO-948)
- 3) Information Disclosure Statement(s) (PTO/SB/08)
Paper No(s)/Mail Date _____
- 4) Interview Summary (PTO-413)
Paper No(s)/Mail Date _____
- 5) Notice of Informal Patent Application
- 6) Other: _____

DETAILED ACTION

Response to Amendment

1. Receipt is acknowledged of the Response to the Election/Restriction Requirement filed September 29, 2006. The applicant elected Group III, claims 22, 23, 35-50, and 59-62 and cancelled claims 1-21, 24-34, 51-58, and 63-74.

Priority

2. Acknowledgment is made of applicant's claim for foreign priority based on an application filed in United Kingdom on November 25, 1999. It is noted, however, that applicant has not filed a certified copy of the 9925227.2 application as required by 35 U.S.C. 119(b).

Oath/Declaration

3. The oath or declaration is defective. A new oath or declaration in compliance with 37 CFR 1.67(a) identifying this application by application number and filing date is required. See MPEP §§ 602.01 and 602.02.

The oath or declaration is defective because:

The oath or declaration contains incorrect application number and filing date.

Claim Objections

4. Claim 41 is objected to because of the following informalities: the word, "warming" inline 2 appears to be - - warning - -. Appropriate correction is required.

5. Claim 44 is objected to because of the following informalities: the claim is missing a period at the end of the claim. Appropriate correction is required.

Claim Rejections - 35 USC § 112

6. The following is a quotation of the second paragraph of 35 U.S.C. 112:

The specification shall conclude with one or more claims particularly pointing out and distinctly claiming the subject matter which the applicant regards as his invention.

7. Claim 35 recites the limitation "a processor" in lines 5 and 6. "a processor" in line 6 appears to be -- said processor -- or -- the processor -- unless the applicant intends to recite two separate processors. There is insufficient antecedent basis for this limitation in the claim.
8. Claim 40 recites the limitation "the card" in line 3. There is insufficient antecedent basis for this limitation in the claim.

Claim Rejections - 35 USC § 102

9. The following is a quotation of the appropriate paragraphs of 35 U.S.C. 102 that form the basis for the rejections under this section made in this Office action:

A person shall be entitled to a patent unless --

(b) the invention was patented or described in a printed publication in this or a foreign country or in public use or on sale in this country, more than one year prior to the date of application for patent in the United States.

10. Claims 22, 23, 35-50, and 59-62 are rejected under 35 U.S.C. 102(b) as being anticipated by Hiroya et al. (US 5,754,654, cited by the applicant).

Re claim 22, Hiroya et al. disclose a method and a system comprising an electronic ticket storage device (2), a terminal device (3), a communication line (4), and an electronic ticket vending and refunding device (1). The electronic ticket storage device further comprises IC chip having a storage unit (31) comprised of various readable/writable storage units (32-36), an I/O interface (37), and a central processing unit (38). The electronic ticket storage device is a data carrier that carries various data such as electronic ticket information, electronic money information, transaction history information, appropriate program information and working area storage space. Fig. 12 of the reference discloses a flowchart illustrating how each element within the system operates a desired function. In the left side of the flowchart, it is disclosed that the

Art Unit: 2876

data carrier (electronic ticket storage device 2) receives a data access request and transmits corresponding data (960 - 1160). For each reception and transmission of data, the data carrier checks the status of electronic ticket and electronic money and responds in accordance with the results of the checking (use rules). At the end of each task, it confirms and evaluates the status of each step according to the results of the evaluation (i.e. checking invalid flags and deletable flags; see column 9, lines 31-67).

Re claim 23, Hiroya et al. disclose the method and the system as recited in rejected claim 22 stated above, wherein said parameter memory (electronic money storage area 33) further stores payment data and further comprising selecting a said use rule (in accordance with the program stored in the program storage area 34) dependent upon said payment data.

Re claim 35, Hiroya et al. disclose a method and a system comprising an electronic ticket storage device (2), a terminal device (3), a communication line (4), and an electronic ticket vending and refunding device (1). The electronic ticket storage device further comprises IC chip having a storage unit (31) comprised of various readable/writable storage units (32-36), an I/O interface (37), and a central processing unit (38). The terminal device (3) is a data access terminal for retrieving data from a data supplier (electronic ticket vending and refunding device 1) and providing the retrieved data to a data carrier (2), the terminal comprising:

- a first interface (communication device 24) for communicating with the data supplier (1);
- a data carrier interface (IC card Reader/Writer) for interfacing with the data carrier (2);
- a program store storing code (storage device 25) implementable by a processor (CPU 27);

and

a processor (27), coupled to the first interface (24), the data carrier interface (26) and to the program store (25) for implementing the stored code, the code comprising:

code to read payment data from the data carrier (2) and to forward the payment data to a payment validation system (steps 270, 290, and 340 in Fig. 5);

code to receive payment validation data from the payment validation system (step 340 receives the acknowledgment of reception of the electronic money data);

code responsive to the payment validation data to retrieve data from the data supplier (1) and to write (350) the retrieved data into the data carrier (2).

Re claim 36, Hiroya et al. disclose the method and the system as recited in rejected claim 35 stated above, further comprising code to transmit (350 and 360) at least a portion of the payment validation data to the data supplier (1) or to a destination received from the data supplier.

Re claim 37, Hiroya et al. disclose the method and the system as recited in rejected claim 36 stated above, further comprising code to retrieve from the data supplier and output to a user stored data identifier data (electronic signature) and associated value data and use rule data for a data item available from the data supplier.

Re claim 38, Hiroya et al. disclose the method and the system as recited in rejected claim 37 stated above, further comprising code to write use rule data for a data item (electronic ticket return/refund rule) into the data carrier (2) with the associated data item.

Re claim 39, Hiroya et al. disclose the method and the system as recited in rejected claim 37 stated above, further comprising code to read a stored value from the data carrier (2), code to compare said stored value with said value data; and code to provide a modified output to a user

of one or more of said stored data identifier data (ticket number), said value data and said use rule data, in response to a result of the comparison (col. 10, ll. 1-23).

Re claim 40, Hiroya et al. disclose the method and the system as recited in rejected claim 35 stated above, further comprising code for user input of access control data (local secret key), code to output the access control data to the data carrier, code to receive access permission data from the card, and code to output data to the user in response to the received access permission data (the local secret key has to match with a public secret key to accomplish a complete electronic money transfer).

Re claim 41, Hiroya et al. disclose the method and the system as recited in rejected claim 40 stated above, further comprising code to output a data erasure warning (deletable flag) in response to the received access permission data.

Re claim 42, Hiroya et al. disclose the method and the system as recited in rejected claim 35 stated above, further comprising code to read reward data (a request for a refund of an unused electronic ticket) from the data carrier and to write modified reward data (updating transaction history storage area) to the data carrier in response to said retrieval of data from the data supplier.

Re claim 43, Hiroya et al. disclose the method and the system as recited in rejected claim 35 stated above, further comprising:

code to read identity data (electronic ticket number) from the data carrier;

code to transmit the identity data to the data supplier (sending the electronic ticket);

code to receive user characterizing data (electronic signature) from the data supplier;

code to retrieve supplementary data (local secret key) in response to said characterizing

data; and

code to output the supplementary data (col. 10, ll. 1-23).

Re claim 44, Hiroya et al. disclose the method and the system as recited in rejected claim 35 stated above, further comprising a cash (electronic cash/money) input device (card reader) coupled to the processor, to provide cash input value data and code to update payment data in the data carrier (2), in accordance with the cash input value data.

Re claim 45, Hiroya et al. disclose the method and the system as recited in rejected claim 35 stated above, integrated with a mobile communication device, a personal computer, an audio/video player, and/or a cable or satellite television interface device (the electronic ticket vending and refunding device is a computer.).

Re claim 46, Hiroya et al. disclose a method and a system comprising an electronic ticket storage device (2), a terminal device (3), a communication line (4), and an electronic ticket vending and refunding device (1). The electronic ticket storage device further comprises IC chip having a storage unit (31) comprised of various readable/writable storage units (32-36), an I/O interface (37), and a central processing unit (38). The method further comprising:

reading payment data (via an IC card reader/writer) from the data carrier (2);

forwarding the payment data to a payment validation system (electronic ticket vending & refunding device 1);

retrieving data from the data supplier (1); and

writing the retrieved data into the data carrier (Fig. 5 and 12).

Re claim 47, Hiroya et al. disclose the method and the system as recited in rejected claim 46 stated above, further comprising:

receiving payment validation data (send the acknowledgement of the reception of the electronic money; step 330 in Fig. 5) from the payment validation system; and

transmitting at least a portion of the payment validation data (Register completion of sending of the electronic money; step 350 in Fig. 5) to the data supplier (1).

Re claim 48, Hiroya et al. disclose the method and the system as recited in rejected claim 47 stated above, wherein the payment validation system comprises a payment processor (CPU 21) at the data supplier (1 and see Fig. 2).

Re claim 49, Hiroya et al. disclose the method and the system as recited in rejected claim 46 stated above, further comprising:

retrieving from the data supplier (1) a stored data item (electronic ticket) identifier and associated value data and use rule data; and

writing use rule data (electronic ticket return/refund rule) for the data item into the data carrier.

Re claim 50, Hiroya et al. disclose the method and the system as recited in rejected claim 48 stated above, further comprising:

reading a stored value (electronic signature) from the data carrier;

comparing the stored value with said value data, and

outputting to a user information indicating the result of said comparing (col. 10, ll. 1-23).

Re claim 59, Hiroya et al. disclose a method and a system comprising an electronic ticket storage device (2), a terminal device (3), a communication line (4), and an electronic ticket vending and refunding device (1). The electronic ticket storage device further comprises IC chip

Art Unit: 2876

having a storage unit (31) comprised of various readable/writable storage units (32-36), an I/O interface (37), and a central processing unit (38). The method further comprising:

retrieving use status data from the data carrier indicating past use of the stored data (electronic ticket);

retrieving use rules from the data carrier (2);

evaluating the use status data (valid/invalid) using the use rules to determine whether access to data stored on the carrier is permitted; and

permitting access to the data on the data carrier dependent on the result of said evaluating (Fig. 12 and col. 19, line 4 – col. 21, line 45).

Re claim 60, Hiroya et al. disclose the method and the system as recited in rejected claim 59 stated above, further writing updated use status data (1190 in Fig. 12) to the carrier after an access attempt.

Re claim 61, Hiroya et al. disclose the method and the system as recited in rejected claim 60 stated above, wherein said use rules permit partial access to a data item and wherein said writing writes a record of what part of the data item has been accessed when only part of the data item has been accessed (The electronic ticket storage area can store more than one ticket information and only a portion of the ticket information can be accessed one at a time.)

Re claim 62, Hiroya et al. disclose the method and the system as recited in rejected claim 59 stated above, further comprising:

inputting a user access data (electronic ticket information data);

selecting the use rules (electronic ticket return/refund rule) dependent upon the user access data.

Conclusion

11. The prior art made of record and not relied upon is considered pertinent to applicant's disclosure.

McGee et al. (US 7,083,081) disclose a method for issuing tickets and a payment processing device with an identifier information.

Any inquiry concerning this communication or earlier communications from the examiner should be directed to Steven S. Paik whose telephone number is 571-272-2404. The examiner can normally be reached on Monday - Friday 5:30a-2:00p (Maxi-Flex*).

If attempts to reach the examiner by telephone are unsuccessful, the examiner's supervisor, Michael G. Lee can be reached on 571-272-2398. The fax phone number for the organization where this application or proceeding is assigned is 571-273-8300.

Information regarding the status of an application may be obtained from the Patent Application Information Retrieval (PAIR) system. Status information for published applications may be obtained from either Private PAIR or Public PAIR. Status information for unpublished applications is available through Private PAIR only. For more information about the PAIR system, see <http://pair-direct.uspto.gov>. Should you have questions on access to the Private PAIR system, contact the Electronic Business Center (EBC) at 866-217-9197 (toll-free). If you would like assistance from a USPTO Customer Service Representative or access to the automated information system, call 800-786-9199 (IN USA OR CANADA) or 571-272-1000.

Steven S. Paik
Primary Examiner
Art Unit 2876

ssp

| | | | |
|-----------------------------------|---------------------------------------|--|-------------|
| Notice of References Cited | Application/Control No. 11/336,758 | Applicant(s)/Patent Under Reexamination HULST ET AL. | |
| | Examiner Steven S. Paik | Art Unit 2876 | Page 1 of 1 |

U.S. PATENT DOCUMENTS

| * | Document Number Country Code-Number-Kind Code | Date MM-YYYY | Name | Classification |
|---|--|-----------------|------------------------|----------------|
| * | A US-5,406,619 | 04-1995 | Akhteruzzaman; et. al. | 379/93.02 |
| * | B US-7,083,081 | 08-2006 | McGee et al. | 235/375 |
| * | C US-7,044,362 | 05-2006 | Yu, Allen K. | 235/375 |
| * | D US-6,999,936 | 02-2006 | Sehr, Richard P. | 705/5 |
| * | E US-5,754,654 | 05-1998 | Hiroya et al. | 705/76 |
| | F US- | | | |
| | G US- | | | |
| | H US- | | | |
| | I US- | | | |
| | J US- | | | |
| | K US- | | | |
| | L US- | | | |
| | M US- | | | |

FOREIGN PATENT DOCUMENTS

| * | Document Number Country Code-Number-Kind Code | Date MM-YYYY | Country | Name | Classification |
|---|--|-----------------|---------|------|----------------|
| | N | | | | |
| | O | | | | |
| | P | | | | |
| | Q | | | | |
| | R | | | | |
| | S | | | | |
| | T | | | | |

NON-PATENT DOCUMENTS

| * | Document Number Country Code-Number-Kind Code | Date MM-YYYY | Country | Name | Classification |
|---|---|-----------------|---------|------|----------------|
| | Include as applicable: Author, Title Date, Publisher, Edition or Volume, Pertinent Pages) | | | | |
| | U | | | | |
| | V | | | | |
| | W | | | | |
| | X | | | | |

*A copy of this reference is not being furnished with this Office action. (See MPEP § 707.05(a).)
Dates in MM-YYYY format are publication dates. Classifications may be US or foreign.

Index of Claims



Application/Control No.

11/336,758

Examiner

Steven S. Paik

Applicant(s)/Patent under Reexamination

HULST ET AL.

Art Unit

2876

| | |
|---|----------|
| ✓ | Rejected |
| ≡ | Allowed |

| | |
|---|--------------------------------|
| - | (Through numeral) Cancelled |
| + | Restricted |

| | |
|---|--------------|
| N | Non-Elected |
| I | Interference |

| | |
|---|----------|
| A | Appeal |
| O | Objected |

| Claim | Date | |
|-------|----------|----------|
| Final | Original | 10/26/06 |
| 1 | | |
| 2 | | |
| 3 | | |
| 4 | | |
| 5 | | |
| 6 | | |
| 7 | | |
| 8 | | |
| 9 | | |
| 10 | | |
| 11 | | |
| 12 | | |
| 13 | | |
| 14 | | |
| 15 | | |
| 16 | | |
| 17 | | |
| 18 | | |
| 19 | | |
| 20 | | |
| 21 | | |
| 22 | ✓ | |
| 23 | ✓ | |
| 24 | | |
| 25 | | |
| 26 | | |
| 27 | | |
| 28 | | |
| 29 | | |
| 30 | | |
| 31 | | |
| 32 | | |
| 33 | | |
| 34 | | |
| 35 | ✓ | |
| 36 | | |
| 37 | | |
| 38 | | |
| 39 | | |
| 40 | | |
| 41 | | |
| 42 | | |
| 43 | | |
| 44 | | |
| 45 | | |
| 46 | | |
| 47 | | |
| 48 | | |
| 49 | | |
| 50 | ✓ | |

| Claim | Date | |
|-------|----------|----------|
| Final | Original | 10/26/06 |
| 51 | | |
| 52 | | |
| 53 | | |
| 54 | | |
| 55 | | |
| 56 | | |
| 57 | | |
| 58 | | |
| 59 | | |
| 60 | ✓ | |
| 61 | ✓ | |
| 62 | ✓ | |
| 63 | | |
| 64 | | |
| 65 | | |
| 66 | | |
| 67 | | |
| 68 | | |
| 69 | | |
| 70 | | |
| 71 | | |
| 72 | | |
| 73 | | |
| 74 | | |
| 75 | | |
| 76 | | |
| 77 | | |
| 78 | | |
| 79 | | |
| 80 | | |
| 81 | | |
| 82 | | |
| 83 | | |
| 84 | | |
| 85 | | |
| 86 | | |
| 87 | | |
| 88 | | |
| 89 | | |
| 90 | | |
| 91 | | |
| 92 | | |
| 93 | | |
| 94 | | |
| 95 | | |
| 96 | | |
| 97 | | |
| 98 | | |
| 99 | | |
| 100 | | |

| Claim | Date | |
|-------|----------|--|
| Final | Original | |
| 101 | | |
| 102 | | |
| 103 | | |
| 104 | | |
| 105 | | |
| 106 | | |
| 107 | | |
| 108 | | |
| 109 | | |
| 110 | | |
| 111 | | |
| 112 | | |
| 113 | | |
| 114 | | |
| 115 | | |
| 116 | | |
| 117 | | |
| 118 | | |
| 119 | | |
| 120 | | |
| 121 | | |
| 122 | | |
| 123 | | |
| 124 | | |
| 125 | | |
| 126 | | |
| 127 | | |
| 128 | | |
| 129 | | |
| 130 | | |
| 131 | | |
| 132 | | |
| 133 | | |
| 134 | | |
| 135 | | |
| 136 | | |
| 137 | | |
| 138 | | |
| 139 | | |
| 140 | | |
| 141 | | |
| 142 | | |
| 143 | | |
| 144 | | |
| 145 | | |
| 146 | | |
| 147 | | |
| 148 | | |
| 149 | | |
| 150 | | |

Search Notes



Application/Control No.

11/336,758

Examiner

Steven S. Paik

Applicant(s)/Patent under Reexamination

HULST ET AL.

Art Unit

2876

SEARCHED

| Class | Subclass | Date | Examiner |
|-------|----------|------------|----------|
| 235 | 380 | | |
| | 382 | | |
| | 492 | 10/26/2006 | SSP |
| | | | |
| | | | |
| | | | |
| | | | |
| | | | |
| | | | |
| | | | |
| | | | |
| | | | |
| | | | |
| | | | |

INTERFERENCE SEARCHED

| Class | Subclass | Date | Examiner |
|-------|----------|------|----------|
| | | | |
| | | | |
| | | | |
| | | | |
| | | | |

**SEARCH NOTES
(INCLUDING SEARCH STRATEGY)**

| | DATE | EXMR |
|---|------------|------|
| EAST | | |
| Text search combined with 235/\$7.ccls. | | |
| Reviewed 10/111,716 | 10/26/2006 | SSP |
| | | |
| | | |
| | | |
| | | |
| | | |
| | | |

EAST Search History

| Ref # | Hits | Search Query | DBs | Default Operator | Plurals | Time Stamp |
|-------|------|---|--|------------------|---------|------------------|
| S1 | 50 | ("5226145" "5367150" "5457746" "5588146" "5677953" "5703951" "5754654" "5794202" "5809241" "5847372" "5889860" "5901330" "5918213" "5923884" "6012634" "6078917" "6119945" "6202056" "6385731" "6424975" "6442570" "6473829" "6510236" "6553413" "6574643").PN. | US-PGPUB; USPAT; USOCR; FPRS; EPO; JPO; DERWENT; IBM_TDB | OR | ON | 2006/10/26 09:43 |
| S2 | 1411 | 235/382.ccls. | US-PGPUB; USPAT; USOCR; FPRS; EPO; JPO; DERWENT; IBM_TDB | OR | ON | 2006/10/24 19:33 |
| S3 | 43 | ("4663664" "5557518" "5621797").PN. OR ("5754654").URPN. | US-PGPUB; USPAT; USOCR | OR | ON | 2006/10/25 07:53 |
| S4 | 3 | ("20060054704" "20060097054" "20060126129").PN. | US-PGPUB; USPAT; USOCR | OR | ON | 2006/10/25 07:54 |
| S5 | 8 | "5936220" | US-PGPUB; USPAT; USOCR; FPRS; EPO; JPO; DERWENT; IBM_TDB | OR | ON | 2006/10/26 09:43 |
| S6 | 10 | ("4341951" "4980910" "5015830" "5221838").PN. OR ("5936220").URPN. | US-PGPUB; USPAT; USOCR | OR | ON | 2006/10/26 11:04 |
| S7 | 2343 | electronic adj cash | US-PGPUB; USPAT; USOCR | OR | ON | 2006/10/26 11:04 |
| S8 | 629 | (electronic adj cash) and "235"/\$7.ccls. | US-PGPUB; USPAT; USOCR | OR | ON | 2006/10/26 11:04 |
| S9 | 26 | (electronic adj cash) and "235"/382.ccls. | US-PGPUB; USPAT; USOCR | OR | ON | 2006/10/26 11:04 |

Under the Paperwork Reduction Act of 1995, no persons are required to respond to a collection of information unless it displays a valid OMB control number.

| PATENT APPLICATION FEE DETERMINATION RECORD | | | | | Application or Docket Number 11,336,758 | | | | | | |
|---|--|----------------------------------|------------|--------------|---|---------------|--------------|-------------------------|-----------|-------------------------|---------------------|
| Substitute for Form PTO-875 | | | | | | | | | | | |
| APPLICATION AS FILED - PART I | | | | | | | | | | | |
| | | (Column 1) | (Column 2) | | SMALL ENTITY | | OR | OTHER THAN SMALL ENTITY | | | |
| FOR | NUMBER FILED | | | NUMBER EXTRA | RATE (\$) | FEE (\$) | | RATE (\$) | FEE (\$) | | |
| BASIC FEE (37 CFR 1.18(a), (b), or (c)) | | | | | | 150 | | | 300 | | |
| SEARCH FEE (37 CFR 1.18(k), (l), or (m)) | | | | | | 250 | | | 500 | | |
| EXAMINATION FEE (37 CFR 1.16(e), (f), or (g)) | | | | | | 100 | | | 200 | | |
| TOTAL CLAIMS (37 CFR 1.16(i)) | 74 | minus 20 = | | 54 | X\$ 25 | 1350 | OR | X\$50 | | | |
| INDEPENDENT CLAIMS (37 CFR 1.16(h)) | 16 | minus 3 = | | 13 | X\$100 | 1300 | OR | X\$200 | | | |
| APPLICATION SIZE FEE (37 CFR 1.16(s)) | If the specification and drawings exceed 100 sheets of paper, the application size fee due is \$250 (\$125 for small entity) for each additional 50 sheets or fraction thereof. See 35 U.S.C. 41(e)(1)(G) and 37 CFR | | | | | | | | | | |
| MULTIPLE DEPENDENT CLAIM PRESENT (37 CFR 1.16(j)) | | | | | 180 | | | 360 | | | |
| | | | | | TOTAL | 3150 | | | | | |
| * If the difference in column 1 is less than zero, enter "0" in column 2. | | | | | | | | | | | |
| APPLICATION AS AMENDED - PART II | | | | | | | | | | | |
| | | (Column 1) | (Column 2) | | (Column 3) | | SMALL ENTITY | | OR | OTHER THAN SMALL ENTITY | |
| AMENDMENT A | 9/29/06 | CLAIMS REMAINING AFTER AMENDMENT | | | HIGHEST NUMBER PREVIOUSLY PAID FOR | PRESENT EXTRA | RATE (\$) | ADDITIONAL FEE (\$) | | RATE (\$) | ADDITIONAL FEE (\$) |
| | Total (37 CFR 1.16(i)) | 22 | Minus ** | | 74 | = | X 25 = | / | OR | X 50 = | / |
| | Independent (37 CFR 1.16(h)) | 4 | Minus *** | | 16 | = | X 50 = | / | OR | 200 | / |
| | Application Size Fee (37 CFR 1.16(s)) | | | | | 180 | | | OR | 360 | |
| FIRST PRESENTATION OF MULTIPLE DEPENDENT CLAIM (37 CFR 1.16(j)) | | | | | TOTAL | | | OR | TOTAL | | |
| | | | | | ADD'T FEE | | | OR | ADD'T FEE | | |
| * If the entry in column 1 is less than the entry in column 2, write "0" in column 3. | | | | | | | | | | | |
| ** If the "Highest Number Previously Paid For" IN THIS SPACE is less than 20, enter "20". | | | | | | | | | | | |
| *** If the "Highest Number Previously Paid For" IN THIS SPACE is less than 3, enter "3". | | | | | | | | | | | |
| The "Highest Number Previously Paid For" (Total or Independent) is the highest number found in the appropriate box in column 1. | | | | | | | | | | | |
| This collection of information is required by 37 CFR 1.16. The information is required to obtain or retain a benefit by the public which is to file (and by the USPTO to process) an application. Confidentiality is governed by 35 U.S.C. 122 and 37 CFR 1.14. This collection is estimated to take 12 minutes to complete, including gathering, preparing, and submitting the completed application form to the USPTO. Time will vary depending upon the individual case. Any comments on the amount of time you require to complete this form and/or suggestions for reducing this burden, should be sent to the Chief Information Officer, U.S. Patent and Trademark Office, U.S. Department of Commerce, P.O. Box 1450, Alexandria, VA 22313-1450. DO NOT SEND FEES OR COMPLETED FORMS TO THIS ADDRESS. SEND TO: Commissioner for Patents, P.O. Box 1450, Alexandria, VA 22313-1450. | | | | | | | | | | | |
| If you need assistance in completing the form, call 1-800-PTO-9199 and select option 2. | | | | | | | | | | | |

RECEIVED
CENTRAL FAX CENTER

SEP 29 2006

I hereby certify that this correspondence is being facsimile transmitted to the United States Patent and Trademark Office, Fax No. 1-571-273-8300 on September 29, 2006.

PATENT
Attorney Docket No.: 080379-000100US
Client Ref. No.: F/USP81421X Con.

TOWNSEND and TOWNSEND and CREW LLP

By: *Alvina M. Munnac*

IN THE UNITED STATES PATENT AND TRADEMARK OFFICE

In re application of:

HULST HERMEN-ARD

Application No.: 11/336,758

Filed: January 19, 2006

For: DATA STORAGE AND ACCESS SYSTEMS

Customer No.: 20350

Confirmation No. 3911

Examiner: Steve S. Paik

Technology Center/Art Unit: 2876

RESPONSE TO RESTRICTION REQUIREMENT

Mail Stop: Amendment
Commissioner for Patents
P.O. Box 1450
Alexandria, VA 22313-1450

Sir:

In response to the Office Action mailed August 29, 2006, please enter the following amendments and remarks:

Amendments to the Claims are reflected in the listing of claims which begins on page 2 of this paper.

Remarks/Arguments begin on page 6 of this paper.

RECEIVED
CENTRAL FAX CENTER

SEP 29 2006

Atty Docket No. 080379-000100U5

PTO FAX NO.: 1-571-273-8300

ATTENTION: Examiner Steve S. Paik

Group Art Unit 2876

**OFFICIAL COMMUNICATION
FOR THE PERSONAL ATTENTION OF
EXAMINER STEVE S. PAIK**

CERTIFICATION OF FACSIMILE TRANSMISSION

I hereby certify that the following documents in re Application of Herman-ard HULST, Application No. 11/366,758, filed January 19, 2006 for DATA STORAGE AND ACCESS SYSTEMS are being facsimile transmitted to the Patent and Trademark Office on the date shown below.

Documents Attached

1. SB/21 Transmittal Form (1 page)
2. Response to Restriction Requirement (8 pages)
3. Substitute Specification (37 pages)
4. Comparison Copy of Substitute Specification (42 pages)

Number of pages being transmitted, including this page: 88

Dated: September 29, 2006

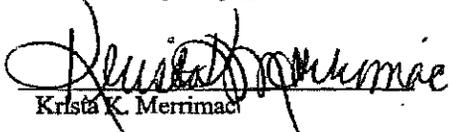
Krista K. Merriman

**PLEASE CONFIRM RECEIPT OF THIS PAPER BY
RETURN FACSIMILE AT (415) 576-0300**

TOWNSEND and TOWNSEND and CREW LLP
Two Embarcadero Center, Eighth Floor
San Francisco, CA 94111-3834
Telephone: 415-576-0200
Fax: 415-576-0300
3994

60881163 v1

RECEIVED
CENTRAL FAX CENTER

002/089

SEP 29 2006

PTO/SB/Z1 (07-38)

| | | |
|--|------------------------|-------------------|
| TRANSMITTAL FORM <small>(to be used for all correspondence after initial filing)</small> | Application Number | 11/336,758 |
| | Filing Date | January 19, 2006 |
| | First Named Inventor | Hulet, Herman-ard |
| | Art Unit | 2876 |
| | Examiner Name | PAJK, Steve S. |
| | Attorney Docket Number | 080379-000100US |
| Total Number of Pages in This Submission | | 88 |

| ENCLOSURES (Check all that apply) | | |
|---|--|---|
| <input type="checkbox"/> Fee Transmittal Form <input type="checkbox"/> Fee Attached <input checked="" type="checkbox"/> Amendment/Reply <input type="checkbox"/> After Final <input type="checkbox"/> Affidavits/declaration(s) <input type="checkbox"/> Extension of Time Request <input type="checkbox"/> Express Abandonment Request <input type="checkbox"/> Information Disclosure Statement <input type="checkbox"/> Certified Copy of Priority Document(s) <input type="checkbox"/> Reply to Missing Parts/ incomplete Application <input type="checkbox"/> Reply to Missing Parts under 37 CFR 1.52 or 1.53 | <input type="checkbox"/> Drawing(s) <input type="checkbox"/> Licensing-related Papers <input type="checkbox"/> Petition <input type="checkbox"/> Petition to Convert to a Provisional Application <input type="checkbox"/> Power of Attorney, Revocation Change of Correspondence Address <input type="checkbox"/> Terminal Disclaimer <input type="checkbox"/> Request for Refund <input type="checkbox"/> CD, Number of CD(s) _____ <input type="checkbox"/> Landscape Table on CD | <input type="checkbox"/> After Allowance Communication to T.O. <input type="checkbox"/> Appeal Communication to Board of Appeals and Interferences <input type="checkbox"/> Appeal Communication to TC (Appeal Notice, Brief, Reply Brief) <input type="checkbox"/> Proprietary Information <input type="checkbox"/> Status Letter <input checked="" type="checkbox"/> Other Enclosure(s) (please identify below): Substitute Specification, Facsimile Coversheet |
| Remarks | | The Commissioner is authorized to charge any additional fees to Deposit Account 20-1430. |

| SIGNATURE OF APPLICANT, ATTORNEY, OR AGENT | | | |
|--|------------------------------------|----------|--------|
| Firm Name | Townsend and Townsend and Crew LLP | | |
| Signature | | | |
| Printed name | Jason D. Loh | | |
| Date | September 29, 2006 | Reg. No. | 48,163 |

| CERTIFICATE OF TRANSMISSION/MAILING | |
|--|--------------------|
| I hereby certify that this correspondence is being facsimile transmitted to the Patent and Trademark Office, Fax No. 1-571-273-8300 on September 29, 2006. | |
| Signature | |
| Typed or printed name | Krista K. Merrimac |
| Date | September 29, 2006 |

60881158 v1

RECEIVED
CENTRAL FAX CENTER

SEP 29 2006

PATENT

Appl. No. 11/366,758
Amdt. dated September 29, 2006
Reply to Office Action of August 29, 2006

BEST AVAILABLE COPY

Amendments to the Claims:

This listing of claims will replace all prior versions, and listings of claims in the application:

Listing of Claims:

Claims 1-21. (Canceled)

22. (Original) A method of controlling access to data on a data carrier, the data carrier comprising non-volatile data memory and non-volatile parameter memory storing use status data and use rules, the method comprising:
receiving a data access request;
reading the use status data and use rules from memory; and
evaluating the use status data using the use rules to determine whether access to the stored data is permitted.

23. (Original) A method as claimed in claim 22 wherein said parameter memory further stores payment data and further comprising selecting a said use rule dependent upon said payment data.

Claims 24-34. (Canceled)

35. (Original) A data access terminal for retrieving data from a data supplier and providing the retrieved data to a data carrier, the terminal comprising:
a first interface for communicating with the data supplier;
a data carrier interface for interfacing with the data carrier;
a program store storing code implementable by a processor; and
a processor, coupled to the first interface, the data carrier interface and to the program store for implementing the stored code, the code comprising:
code to read payment data from the data carrier and to forward the payment data to a payment validation system;
code to receive payment validation data from the payment validation system;

Appl. No. 11/366,758
Amndt. dated September 29, 2006
Reply to Office Action of August 29, 2006

PATENT

code responsive to the payment validation data to retrieve data from the data supplier and to write the retrieved data into the data carrier.

36. (Original) A data access terminal as claimed in claim 35 further comprising code to transmit at least a portion of the payment validation data to the data supplier or to a destination received from the data supplier.

37. (Previously Presented) A data access terminal as claimed in claim 35 further comprising code to retrieve from the data supplier and output to a user stored data identifier data and associated value data and use rule data for a data item available from the data supplier.

38. (Original) A data access terminal as claimed in claim 37 further comprising code to write use rule data for a data item into the data carrier with the associated data item.

39. (Previously Presented) A data access terminal as claimed in claim 37 further comprising code to read a stored value from the data carrier, code to compare said stored value with said value data; and code to provide a modified output to a user of one or more of said stored data identifier data, said value data and said use rule data, in response to a result of the comparison.

40. (Previously Presented) A data access terminal according to claim 35 further comprising code for user input of access control data, code to output the access control data to the data carrier, code to receive access permission data from the card, and code to output data to the user in response to the received access permission data.

41. (Original) A data access terminal as claimed in claim 40 further comprising code to output a data erasure warning in response to the received access permission data.

Appl. No. 11/366,758
Amdt. dated September 29, 2006
Reply to Office Action of August 29, 2006

PATENT

42. (Previously Presented) A data access terminal according to claim 35 further comprising code to read reward data from the data carrier and to write modified reward data to the data carrier in response to said retrieval of data from the data supplier.

43. (Previously Presented) A data access terminal according to claim 35 further comprising:

- code to read identity data from the data carrier;
- code to transmit the identity data to the data supplier;
- code to receive user characterizing data from the data supplier;
- code to retrieve supplementary data in response to said characterizing data; and
- code to output the supplementary data.

44. (Previously Presented) A data access terminal according to claim 35 further comprising a cash input device coupled to the processor, to provide cash input value data and code to update payment data in the data carrier, in accordance with the cash input value data

45. (Previously Presented) A data access terminal according to claim 35 integrated with a mobile communication device, a personal computer, an audio/video player, and/or a cable or satellite television interface device.

46. (Original) A method of providing data from a data supplier to a data carrier, the method comprising:

- reading payment data from the data carrier;
- forwarding the payment data to a payment validation system;
- retrieving data from the data supplier; and
- writing the retrieved data into the data carrier.

47. (Original) A method of providing data from a data supplier according to claim 46 further comprising:

- receiving payment validation data from the payment validation system; and
- transmitting at least a portion of the payment validation data to the data supplier.

Appl. No. 11/366,758
Amdt. dated September 29, 2006
Reply to Office Action of August 29, 2006

PATENT

48. (Original) A method of providing data as claimed in claim 47, wherein the payment validation system comprises a payment processor at the data supplier.

49. (Previously Presented) A method of providing data as claimed in claim 46 further comprising:

retrieving from the data supplier a stored data item identifier and associated value data and use rule data; and

writing use rule data for the data item into the data carrier.

50. (Previously Presented) A method of providing data as claimed in claim 48. further comprising:

reading a stored value from the data carrier;

comparing the stored value with said value data; and

outputting to a user information indicating the result of said comparing.

Claims 51-58. (Canceled)

59. (Original) A method of controlling access to data from a data carrier, comprising:

retrieving use status data from the data carrier indicating past use of the stored data;

retrieving use rules from the data carrier;

evaluating the use status data using the use rules to determine whether access to data stored on the carrier is permitted; and

permitting access to the data on the data carrier dependent on the result of said evaluating.

60. (Original) A method of controlling access according to claim 59, further comprising:

writing updated use status data to the carrier after an access attempt.

App. No. 11/366,758
Amdt. dated September 29, 2006
Reply to Office Action of August 29, 2006

PATENT

61. (Original) A method of controlling access according to claim 60, wherein said use rules permit partial access to a data item and wherein said writing writes a record of what part of the data item has been accessed when only part of the data item has been accessed.

62. (Previously Presented) A method of controlling access according to claim 59, further comprising:

inputting a user access data;

selecting the use rules dependent upon the user access data.

Claims 63-74. (Canceled)

Appl. No. 11/366,758
Amdt. dated September 29, 2006
Reply to Office Action of August 29, 2006

RECEIVED
CENTRAL FAX CENTER

PATENT

SEP 29 2006

REMARKS/ARGUMENTS

This Amendment is in response to the Office Action mailed August 29, 2006. Claims 1-74 were pending in the present application. This Amendment cancels claims 1-21, 24-34, 51-58, and 63-74, without adding or amending any claims, leaving pending in the application claims 22-23, 35-50, and 59-62. Consideration of the elected claims is respectfully requested.

I. Restriction of the Claims.

The claims are subjected to restriction under 35 U.S.C. §121 as being drawn to groups classified as:

Group I: Claims 1-9, as being drawn to a method of providing portable data;

Group II: Claims 10-21, 51-58, 67, and 68, as being drawn to a portable data carrier;

Group III: Claims 22-23, 35-50, and 59-62, as being drawn to a method and apparatus of controlling access to data; and

Group IV: Claims 24-34, 63-66, and 68-74, as being drawn to a system controlled by data bearing records.

Although Applicants do not necessarily agree with these groupings and/or the need for restriction, Applicants hereby elect to prosecute the claims of Group III without traverse. Applicants reserve the right to present the non-elected claims in subsequent continuing applications. Applicants hereby cancel the claims of Groups I, II, and IV, and request consideration and examination of the claims of Group III (claims 22-23, 35-50, and 59-62).

II. Substitute Specification

Submitted with this response is a substitute specification under 37 C.F.R. §1.125. This substitute specification is submitted in order to correct various informalities and typographical errors in the specification. This substitute specification does not include any new matter. The substitute specification is attached in two versions as required, a version with marking showing all the changes relative to the immediate prior version of the specification of record, and an

Appl. No. 11/366,758
Amdt. dated September 29, 2006
Reply to Office Action of August 29, 2006

RECEIVED
CENTRAL FAX CENTER
PATENT
SEP 29 2006

accompanying clean version without markings. Applicants respectfully request acceptance of the substitute specification.

CONCLUSION

In view of the foregoing, Applicants believe all claims now pending in this Application are in condition for allowance. The issuance of a formal Notice of Allowance at an early date is respectfully requested.

If the Examiner believes a telephone conference would expedite prosecution of this application, please telephone the undersigned at 650-326-2400.

Respectfully submitted,

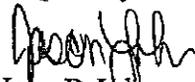
Jason D. Lehr
Reg. No. 48,163

TOWNSEND and TOWNSEND and CREW LLP
Two Embarcadero Center, Eighth Floor
San Francisco, California 94111-3834
Tel: 650-326-2400
Fax: 650-326-2422
JDL/acm
60876654 v1

Attorney Docket No.: 080379-000100US
Client Reference No.: F/USP81421X

SUBSTITUTE SPECIFICATION

DATA STORAGE AND ACCESS SYSTEMS

BACKGROUND OF THE INVENTION

5 [0001] This invention is generally concerned with data storage and access systems. More particularly, it relates to a portable data carrier for storing and paying for data and to computer systems for providing access to data to be stored. The invention also includes corresponding methods and computer programs. The invention is particularly useful for managing stored audio and video data, but may also be applied to storage and access of text
10 and software, including games, as well as other types of data.

[0002] One problem associated with the increasingly wide use of the internet is the growing prevalence of so-called data pirates. Such pirates obtain data either by unauthorized or legitimate means and then make this data available essentially world-wide over the internet
15 without authorization. Data can be a very valuable commodity, but once it has been published on the internet it is difficult to police access to and use of it by Internet users who may not even realize that it is pirated. This is a particular problem with audio recordings, and, once the bandwidth becomes available, is also likely to be evident with video.

20 [0003] Over the past three or four years compressed audio sources have become increasingly widely available on web pages. One widely used audio data compression format is MP3 (MPEG - Audio Layer 3 of the MPEG1 compression algorithm), which is an internationally defined standard including a definition of compressed audio information such as speech or music. It relies on psycho-acoustic properties of human hearing to achieve very large data
25 compression factors. It is thus feasible to download usefully long passages of music in a practically convenient short time. Pirate data suppliers have not been slow to realize the potential of this, and many unauthorized websites have sprung up offering popular music, including recent releases by world-famous bands. This has caused the recording industry considerable concern and there is an urgent need to find a way to address the problem of data
30 piracy.

SUMMARY OF THE INVENTION

- [0004] According to the present invention there is therefore provided a method of providing portable data comprising providing a portable data storage device comprising downloaded data storage means and payment validation means; providing a terminal for internet access;
- 5 coupling the portable data storage device to the terminal; reading payment information from the payment validation means using the terminal; validating the payment information; and downloading data into the portable storage device from a data supplier.
- [0005] Another aspect of the invention provides a corresponding mobile data retrieval device
- 10 for retrieving and outputting data such as stored music and/or noise from the data storage device.
- [0006] The payment validation means is, for example, means to validate payment with an external authority such as a bank or building society. The combination of the payment
- 15 validation means with the data storage means allows the access to the downloaded data which is to be stored by the data storage means, to be made conditional upon checked and validated payment being made for the data. Binding the data access and payment together allows the legitimate owners of the data to make the data available themselves over the internet without fear of loss of revenue, thus undermining the position of data pirates.
- 20 [0007] A further advantage of the system is that it allows users under the age of 18 to make internet purchases. Currently internet users pay for goods and/or services by credit card. Since credit cards cannot legitimately be used by persons under the age of 18 (at least in the UK), a significant fraction of adventurous internet users are excluded from e-commerce, one
- 25 of the most significant predicted uses of the internet. In one embodiment of the invention, however, the payment validation means comprises e-cash; that is, the payment validation means stores transaction value information on a cash value of transactions validatable by the data storage means. In simple terms, the data storage means can be a card which is charged up to a desired cash value (if necessary limited to a maximum value) at a suitable terminal.
- 30 This might be an internet access terminal but could, more simply, be a device to accept the data storage card and to receive and count money deposited by the user to charge the card, writing update cash value information onto the card. More sophisticated ways of updating the cash value on the card are also possible, such as direct bank transfer. Since, with this type of embodiment, the data storage means is, essentially, precharged with cash rather than acting
- 35 as a credit card, it can be used by young people without the risk of their incurring large debts.

[0008] In one embodiment the data storage means is powered by the retrieval device when it is connected to the device and retains a memory of the downloaded data when it is unpowered. This can be achieved by the use of Flash RAM or, more generally, any form of programmable read-only memory. Alternatively the data storage means may incorporate a rechargeable cell or capacitor and store information in battery backed-up static RAM.

[0009] The downloaded data may be entered into the data storage device by means of an interface such as a magnetically or capacitatively coupled connection or an optical connection, but preferably the interface comprises contacts for direct electrical connection to the storage means. The payment validation means may likewise have one of a variety of interfaces but again preferably comprises a set of electrical contacts. The payment validation means could, however, comprise a magnetic or holographic data-strip such as is known for use with credit cards and phone cards. The interface to receive the downloaded data may be separate from the interface to the payment validation means, to facilitate separate and simultaneous access to both these systems. In other embodiments a single interface may serve for both data storage and payment. Advantageously the payment validation means includes a memory storing information to identify the person who is paying for the downloaded data.

[0010] For additional security the downloaded data may be encrypted. In this case data decryption may be necessary at some stage, either in the data storage means or in the retrieval device or in an information delivering apparatus such as a data access terminal. Alternatively the data decryption function can be shared amongst one or more of these devices. The skilled person will be aware of a range of suitable encryption/decryption techniques, including Pretty Good Privacy (Registered Trade Mark) and PKI (Public Key Infrastructure). Normally when the downloaded data is encrypted a decryption key must be supplied. This can be generated automatically by the data access terminal or data access service provider or it can be entered by the user into the data access terminal or into the mobile data retrieval device.

[0011] The data storage means and/or the retrieval device can be provided with access control means to prevent unauthorized access to the downloaded data. Additionally or alternatively, use control means can be provided to stop or provide only limited access of the user to the downloaded data in accordance with the amount paid. These access and use control functions may in some embodiments be combined, permitted use controlling access

or permitted access controlling use. Thus, for example, a complete set of data information relating to a particular topic, a particular music track, or a particular software package might be downloaded, although access to part of the data set might thereafter be controlled by payments made by a user at a later stage. In this way, a user could pay to enable an extra
5 level on a game or to enable further tracks of an album.

[0012] In embodiments where the access or use control means is responsive to the payment validation means, access or use control information may be stored with the downloaded data or in a separate storage area, for example in the payment validation means. The user's access
10 to the downloaded data could advantageously be responsive to the payment validation means, for example, by means of a control line coupling the payment validation means with a memory access or decryption control element.

[0013] In one embodiment the data storage means comprises an electronic memory card or
15 smart card and the mobile data retrieval device is provided with a slot to receive the card. Preferably the card is a push-fit within the retrieval device, and retention of the card may be effected by pressure from electrical interface connections and/or resilience of the housing, or by using a resilient retaining means. In a preferred embodiment the retrieval device includes an audio output and a display, to play a downloaded track and to show information about the
20 track and/or an accompanying video.

[0014] To download data onto the data storage means the user can employ a data access terminal coupled to the internet. The terminal can directly validate payment; for example in the case of a smart card charged with electronic cash it can deduct a cash value from the card.
25 Alternatively it can communicate with a bank or other financial services provider to control payment. In a preferred embodiment, however, the terminal connects to a data access service provider which provides a portal to other sites and which validates payment and then forwards data from a data supplier to the user's local access terminal. The data access service provider may alternatively forward payment validation information and/or information from
30 the payment validation authority to the data supplier for control by the supplier of the data supplied. Thus, access to the payment validation system and/or data for downloading may be entirely controlled by the data supplier.

[0015] Data held on the data storage means may advantageously include data relating to the
35 user's or payer's usage of the system. This information may include, for example,

information on a user's spending pattern, information on data suppliers used and information on the downloaded data. This information may be accessed by the data supplier and/or data access service provider and can be used for targeted marketing or loyalty-based incentive schemes such as air miles or the like.

5
[0016] The data access terminal may be a conventional computer or, alternatively, it may be a mobile phone. Wireless Application Protocol (WAP) and i-mode allow mobile phones to efficiently access the internet and this allows a mobile phone to be used to download data to the data storage means, advantageously, directly. The data storage means can, if desired,
10 incorporate the functionality of a mobile phone SIM (Subscriber Identity Module) card, which cards already include a user identification means, to allow user billing through the phone network operator.

[0017] In a preferred embodiment the downloaded data is MP3 or other encoded audio data,
15 but the system finds more general application for other data types. For example, download data can include software, and particularly games, share price information, current news information, transport timetable information, weather information and catalog shopping information. The downloaded information may also include compressed video data. The storage capacity of the data storage means is adaptable to suit the type of data intended to be
20 downloaded; for example, 32 megabytes is sufficient for CD quality music, but for video it is preferable that the data storage means has a capacity of 128 megabytes or greater.

[0018] In another aspect, the invention provides a portable data carrier comprising an interface for reading and writing data from and to the carrier; non-volatile data memory,
25 coupled to the interface, for storing data on the carrier; non-volatile payment data memory, coupled to the interface, for providing payment data to an external device.

[0019] These features allow the data carrier to store both payment data and content data, thus providing the advantages outlined above. Depending upon the payment system used, the
30 payment data memory may also store code for validating or confirming a payment to an external payment system. The payment data will normally be linked to a card or card holder identification data for payment by the card holder. The non-volatile memory ensures that stored content and payment data is retained in the data carrier when the data carrier is not receiving power from an external source. Thus "non-volatile" encompasses, for example,
35 low-power memory whose contents are retained by a battery back-up system. In one

embodiment the payment data memory comprises EEPROM and the content data memory comprises Flash memory, but other types of content data memory, such as optical, for example, holographic, data memory can also be used. The data carrier may also be integrated into other apparatus, such as a mobile communications device.

5

[0020] Preferably, the portable data carrier further comprises a program store for storing code implementable by a processor; and a processor, coupled to the content data memory, the payment data memory, the interface and to the program store for implementing code in the program store, wherein the code comprises code to output payment data from the payment data memory to the interface and code to provide external access to the data memory.

10

[0021] Normally, the (content) data memory allows both write and read access for both storing and retrieving data, but in some embodiments the content data memory may be read-only memory (ROM). In such embodiments, content may be pre-loaded onto the carrier and payment may then be made for permission to access the pre-loaded data.

15

[0022] Preferably, the data carrier also stores a record of access made to the content data and updates this in response to external access, preferably read access, made to the data memory. The carrier may also store content use rules pertaining to allowed use of stored data items.

20

These use rules may be linked to payments made from the card to provide payment options such as access to buy content data outright; rental access to content data for a time period or for a specified number of access events; and/or rental/purchase, for example where rental use is provided together with an option to purchase content data at the reduced price after rental access has expired.

25

[0023] Thus where the data carrier stores, for example, music, the purchase outright option may be equivalent to the purchase of a compact disc (CD), preferably with some form of content copy protection such as digital watermarking. In this example, the rental or subscription payment option may be a pay-per-play option, and with this option payment may either be before or after access to the stored data so that the carrier may operate in either a debit or credit payment mode.

30

[0024] The portability of the data carrier potentially allows it to be used to access content or, in the example, play music without the need to be linked to a communications system or to be on-line to the internet. By providing a use record memory on the data carrier, use of the

35

stored data can be tracked while off-line and then any necessary payment can be made when the data carrier is next coupled to a communication system. This allows the data carrier to operate in a credit mode. In a debit mode, the additional storage of use rules facilitates the regulation of access to content data stored on the carrier without the need for further exchange of payment/use data with an external system to validate the use.

5
10 [0025] By combining digital rights management with content data storage using a single carrier, the stored content data becomes mobile and can be accessed anywhere while retaining control over the stored data for the data content provider or data copyright owner. Preferably, the data carrier also stores access control data, such as a user ID and a password, as the stored data may be valuable. The access control data may be combined with access control to the payment data, which is typically by means of a PIN (Personal Identification Number) to simplify access to valued content stored on the carrier.

15 [0026] In one embodiment the stored content data is encrypted and a unique password or PIN and/or biometric data is required for decryption. The data carrier may be arranged so that the content is erased after a predetermined number of incorrect access attempts. Additionally or alternatively, a permanently stored flag may be set and/or a hardware modification (such as a fusible link) may be made to prevent the data carrier from functioning for further data storage/retrieval. Preferably, however, access to any stored value/payment data is nevertheless retained.

25 [0027] Supplementary data may also be stored on the carrier in association with stored content data. This supplementary data may comprise customer reward management data and/or advertising data. The supplementary data may comprise a pointer to an external data source from which data is downloaded either to the data carrier or to a data access device or content player, so that advertising or other data can be displayed when reviewing or accessing the stored content.

30 [0028] Additional data security and/or a mechanism for rewarding operators at different levels in the data supply chain may be provided using a content synthesis function. The content synthesis function combines partial content information from two or more sources to provide content data items for storage and/or output. Thus, for example, a first percentage of a content data item could be provided by a content retailer, while a remaining percentage
35 could be provided by an on-line data supplier. This would provide an incentive for a user to

register with a content retailer or distributor as well as with an on-line system owner and so could encourage the use of existing retailers and could provide a mechanism for paying commission to such retailers. The two portions of data combined to provide a content data item could comprise encryption data and a key but preferably comprise separate parts of a complete data item, for example, least significant bits and most significant bits or high 5 frequencies and low frequencies (for audio). This arrangement also facilitates customer reward and loyalty management.

[0029] In one embodiment the data carrier further comprises memory for storing data for 10 accessing a mobile communications network, for example to receive content data over the network. For such an embodiment, the data carrier may replace a SIM (Subscriber Identity Module) card in a mobile communications device, thus providing a single card for both network access and valued content retrieval and storage. Additionally or alternatively the card may also store the web address of a data supplier from whom data may be downloaded 15 onto the carrier.

[0030] The data memory for storing content data may be optic, magnetic or semiconductor memory, but preferably comprises Flash memory. Preferably, the data memory has a large capacity for storing large data files such as compressed video data. Preferably, the data 20 memory is partitioned for lock access, that is, for read and/or write access to blocks of, for example, 1K, 4K, 16K or 64K databytes for faster data access, particularly where the stored content data will normally be accessed serially, as is normally the case with audio and video data. Preferably the card is configured as an IC card or smart card and has a credit card-type format, although other formats such as the "memory stick" format may also be used. This 25 provides a small and convenient portable format and facilitates removable interfacing with a variety of devices.

[0031] The invention also provides a related method of controlling access to data on a data carrier, the data carrier comprising non-volatile data memory and non-volatile parameter 30 memory storing use status data and use rules, the method comprising receiving a data access request; reading the use status data and use rules from memory; and evaluating the use status data using the use rules to determine whether access to the stored data is permitted.

[0032] According to another aspect of the invention, there is provided a computer system for 35 providing data to a data requester, the system comprising a communication interface; a data

access data store for storing records of data items available from the system, each record comprising a data item description and a pointer to a data provider for the data item; a program store storing code implementable by a processor; a processor coupled to the communications interface, to the data access data store, and to the program store for
5 implementing the stored code, the code comprising code to receive a request for a data item from the requester; code to receive from the communications interface payment data comprising data relating to payment for the requested data item; code responsive to the request and to the received payment data, to read data for the requested data item from a content provider; and code to transmit the read data to the requester over the communications
10 interface.

[0033] The computer system is operated by a data supplier or data supply "system owner" for providing content data to the data carrier described above. The payment data received may either be data relating to an actual payment made to the data supplier, or it may be a record of
15 a payment made to an e-payment system relating either to a payment to the data supplier, or to a payment to a third party. The data from the content provider, preferably without permanent (local) storage of the forwarded data, improves data security as the content provider retains control over a content data item, and the data supplier, a copy of a data item, is unable to supply data for the item without the content provider's assistance. The computer
20 system may provide temporary storage for a requested data item, for example using a disk cache, but preferably the computer system does not store a complete data item, even temporarily.

[0034] Preferably, the computer system includes payment distribution information so that
25 when payment is made for a data item, the payment can be distributed for reimbursing royalties and making other payments. Typically a large fraction of the payment for a data item will be transferred to a copyright owner or "content provider" for the item, while smaller payments will go to the artist and/or publisher and/or retailer/distributor. Payment may be made directly by the computer system to the computer systems of other relevant parties
30 using, for example, a signature-transporting type e-payment system. Alternatively, the computer system can issue appropriate instructions to a third party e-payment system for making the transfers. The computer system allows automatic distribution of payments either before, during or after content data download, or after content data access by a user. Instructions for distributing the payments may be issued substantially simultaneously, thereby

avoiding long delays in the payment of some parties; for example, it can presently take a year or more for an artist generating content to be paid by conventional methods.

5 [0035] Preferably, the computer system also stores content data item access rule data, for downloading in association with a content data item. The rule data may be stored by a content provider but is preferably held by the computer system, and links a content identifier with an access rule, typically based upon a required payment value, as outlined above in the context of the data carrier. Normally, each content data item will have an associated access rule, but a single rule may apply to a large number of data items. The computer system also, 10 preferably, stores requester reward data for customer reward/loyalty management. This data may again comprise one or more rules linking a payment value and/or content data item type to a specified reward, such as a number of air miles or retailer value points. The computer system preferably also keeps a record of an identified user's or data's carriers content item downloads and payments for market research purposes.

15 [0036] The computer system, in one embodiment, also stores access control data, such as an access request identity and password which can be employed, for example, to create an extranet of system users, which again can be linked to stored access record data for marketing purposes. When further linked to content item type data, such an arrangement can be used to 20 construct a club of users of content data items of a particular type, for example country and western or rock and roll music. As described in connection with the portable data carrier, the computer system may also comprise content synthesis code for additional data security and for more secure management of payment distributions.

25 [0037] The invention also provides a related method of providing data to a data requester comprising receiving a request for a data item from the requester; receiving payment data from the requester relating to payment for the requested data; reading the requested data from a content provider responsive to the received payment data; and transmitting the read data to the requester.

30 [0038] According to a further aspect of the present invention, there is provided a data access terminal for retrieving data from a data supplier and providing the retrieved data to a data carrier, the terminal comprising a first interface for communicating with the data supplier; a data carrier interface for interfacing with the data carrier; a program store storing code 35 implementable by a processor; and a processor, coupled to the first interface, the data carrier

interface and to the program store for implementing the stored code, the code comprising:
code to read payment data from the data carrier and to forward the payment data to a payment
validation system; code to receive payment validation data from the payment validation
system; code responsive to the payment validation data to retrieve data from the data supplier
5 and to write the retrieved data into the data carrier.

[0039] This terminal can be used for retrieving data from the above-described computer
system and for downloading the retrieved data to the above-described portable data carrier.
As with the data supply computer system, it is preferable that there is no (local) storage of
10 content item data forwarded from the data supplier to the data carrier. The data access
terminal is not restricted to use with the above-described status supplier and could, for
example, retrieve data for downloading to the data carrier from a local data source, such as a
CD (Compact Disc) or DVD (Digital Versatile Disc), or from a third party such as a cable TV
company.

15 [0040] The terminal reads payment data from the data carrier and transmits this to a payment
validation system for validating the data and authorizing the payment. This may be part of
the data supplier's computer system or it may be a separate system such as an e-payment
system. Thus, the terminal operates with a data carrier storing payment (validation) data and,
20 in some embodiments, additional payment validation code for validating payment to the
payment validation system. Again, the terminal is preferably configured to provide a data
item use rule to the carrier in conjunction with a data item. As before, the data item use rule
will normally be dependent upon payment value information embodied in the payment data
read from the data carrier. The terminal is preferably also configured for user input of access
25 control data. This access control data may be forwarded to the data carrier for access
permission verification and/or it may be passed to the data supplier computer system for a
similar purpose. The terminal may be configured to warn a user of content access or data
carrier function inhibition after a predetermined number of access requests have been refused.
The terminal may also incorporate content synthesis code as described above.

30 [0041] The terminal may comprise code to output supplementary data when downloading
data to the data carrier. Identity data on the data carrier can be used to retrieve the
supplementary data, or a pointer to the supplementary data, from the data supplier computer
system, or the supplementary data or a pointer thereto can be retrieved directly from the data
35 carrier. Preferably, however, identification data on the card is used to retrieve characterizing

data such as card user preference data from the data supplier computer system, and this characterizing data is then used by the terminal to retrieve and output supplementary data to a terminal user. When the terminal is associated with a contact distributor or retailer, the supplementary data may be retrieved over a network associated with the retailer/distributor
 5 such as a local area network (LAN), wide area network (WAN) or extranet.

[0042] The invention also provides a method of providing data from a data supplier to a data carrier, the method comprising reading payment data from the data carrier; forwarding the payment data to a payment validation system; retrieving data from the data supplier; and
 10 writing the retrieved data into the data carrier.

[0043] The payment validation system may be part of the data supplier's computer systems or it may be a separate e-payment system. In one embodiment the method further comprises receiving payment validation data from the payment validation system; and transmitting at
 15 least a portion of the payment validation data to the data supplier. Alternatively the payment validation system may comprise a payment processor at the data supplier or at a destination retrieved from the data supplier. The payment processor may also provide payment distribution data for distributing a payment represented by the payment data.

[0044] In a further aspect, the invention provides a data access device for retrieving stored data from a data carrier, the device comprising a user interface; a data carrier interface; a program store storing code implementable by a processor; and a processor coupled to the user interface, to the data carrier interface and to the program store for implementing the stored code, the code comprising code to retrieve use status data indicating a use status of data
 20 stored on the carrier, and use rules data indicating permissible use of data stored on the carrier; code to evaluate the use status data using the use rules data to determine whether access is permitted to the stored data; and code to access the stored data when access is permitted.

[0045] The data access device uses the use status data and use rules to determine what access is permitted to data stored on the data carrier. As described above, the use rules will normally be dependent upon payments made for data stored on the data carrier, but may also comprise access control employing a user identification and password. Since a single data carrier may have more than one user, the use status and use rules may be selected dependent
 35 upon a user identity. The data access device may also be configured to present

supplementary data when presenting the content data, retrieved as described above, from the card, from a remote computer system or from some other source such as a cable TV network or off-air.

5 [0046] The invention also provides a related method of controlling access to data from a data carrier, comprising retrieving use status data from the data carrier indicating past use of the stored data; retrieving use rules from the data carrier; evaluating the use status data using the use rules to determine whether access to data stored on the carrier is permitted; and permitting access to the data on the data carrier dependent on the result of said evaluating.

10 [0047] According to a further aspect of the invention there is provided a data access system comprising a data supply computer system for forwarding data from a data provider to a data access terminal; a electronic payment system for confirming an electronic payment; a data access terminal for communicating with the data supply system to write data from the data supply system onto a data carrier; and a data carrier for storing data from the data supply system and payment data; wherein data is forwarded from the data provider to the data carrier on validation of payment data provided from the data carrier to the electronic payment system.

20 [0048] In a further aspect of the invention, there is provided a portable data carrier comprising an interface for sending and receiving data from and to the carrier; non-volatile data memory, coupled to the interface, for storing data on the carrier; and a digital rights management processor for controlling access to the stored data.

25 [0049] In a further aspect of the invention, there is provided a portable data carrier comprising an interface for sending and receiving data from and to the carrier; non-volatile data memory, coupled to the interface, for storing data on the carrier; and an access control processor; wherein the data memory is partitioned as data blocks and the access control processor controls external access to the data blocks.

30 [0050] In a further aspect of the invention, there is provided a computer system for providing data to a data requester, the system comprising a communication interface; a data access data store for storing records of data items available from the system, each record comprising a data item description and a resource locator; a data provider for the data item; a program store storing code implementable by a processor; a processor coupled to the communications

35

interface, to the data access data store, and to the program store for implementing the stored code, the code comprising code to receive a request for a data item from the requester to receive from the communications interface payment data comprising data relating to payment for the requested data item; code, responsive to the request and to the received payment data,
5 to output the item data to the requester over the communication interface; wherein said data access data store further comprises payment distribution information indicating to whom payments should be made for a data item; and further comprising code to output payment data for a data item for making payments for the item when the item is supplied to a requester.

10 **[0051]** In a further aspect of the invention, there is provided a computer system for providing data to a data requester, the system comprising a communication interface; a data access data store for storing records of data items available from the system, each record comprising a data item description and a printer location data identifying an electronic address for a
15 provider for the data item; a program store storing code implementable by a processor; a processor coupled to the communications interface, to the data access data store, and to the program store for implementing the stored code, the code comprising code to receive a request for a data item from the requester to receive from the communications interface payment data comprising data relating to payment for the requested data item; code
20 responsive to the request and to the received payment data to output the item data to the requester over the communication interface; wherein the data access data store further comprises data item access rule data for output to the requester with a data item; and further comprising code to select access rule data for output with a data item in response to the payment data.

25 **[0052]** In a yet further aspect of the invention, there is provided a method of providing data to a data requester comprising receiving a request for a data item from the requester; receiving payment data from the requester relating to payment for the requested data; transmitting the requested data to the requester; reading payment distribution information
30 from a data store; and outputting payment data to a payment system for distributing the payment for the requested data.

[0053] In a still further aspect of the invention, there is provided a method of providing data to a data requester comprising receiving a request for a data item from the requester;
35 receiving payment data from the requester relating to payment for the requested data;

transmitting the requested data to the requester; and transmitting data access rule data to the requester with the read data.

[0054] These and other aspects of the invention will now be further described, by way of
5 example only, with reference to the accompanying figures.

BRIEF DESCRIPTION OF THE DRAWINGS.

[0055] Figure 1 shows a data access device a) from the top; b) from the front; and c) from the
10 side;

[0056] Figure 2 shows, conceptually, a portable data carrier;

[0057] Figures 3a and b show exemplary data access terminals;

15 [0058] Figures 4a and b show, respectively, a logical signal path between elements of a
conceptual data access system; and a physical representation of a conceptual data access
system;

[0059] Figure 5 shows a content provision system;

20 [0060] Figure 6 shows a data supply computer system;

[0061] Figure 7 shows a variety of data access terminals;

25 [0062] Figure 8 shows a schematic diagram of components of a data access terminal;

[0063] Figure 9 shows a schematic diagram of components of a data carrier;

[0064] Figure 10 shows a schematic diagram of components of a data access device;

30 [0065] Figures 11a and 11b are flow diagrams of a data carrier registration process;

[0066] Figures 12a-c and 12d-e show, respectively, a flow diagram of data access using a
data access terminal; and a flow diagram of data supply using a data supply computer system;

35 and

[0067] Figure 13 shows a flow diagram of data retrieval using a data access device.

DESCRIPTION OF THE PREFERRED EMBODIMENTS

- [0068] Referring to Figure 1, this shows a data access device for playing MP3 audio (10) with operator controls (12) and LCD display (14). The outline of a smart card data storage device is shown at (16). The operator controls allow a user to select and play tracks, while track information and still or video images are provided on display (14). A slot (18) is provided in the front of the device to receive a smart card-type data storage means. This smart card occupies space (20) and interfaces with resilient contacts (24); it is held in the data retrieval device against the contacts, by resilient housing element (22).
- 10 [0069] Referring now to Figure 2, this shows a portable data carrier (30) suitable for use with the device of Figure 1. The data storage means is based on a standard smart card; it is plastic, about the size of a standard credit card, and has some flexibility. On the card (30) are two sets of contacts, contacts (32) for interfacing with the payment validation means and contacts (34) for interfacing with the memory for storing downloaded data (although in other
15 embodiments, a single set of contacts may be used for both). The surface of the card can be embellished with suitable graphics.
- [0070] In one embodiment the smart card retains all its useable functionality as specified for standard Electronics Point of Sale Systems (EPOSS) and, if desired, the memory for storing
20 the downloaded data can be electrically separate from this. However, it may be preferable to provide interaction between the standard smart card device and the data memory in order to accomplish the access control/decryption functions described above.
- [0071] Referring now to Figure 3, an example of a data access terminal is shown at (40).
25 This has a screen (42) and a slot (44) to receive the data carrier (30). Alternatively the data carrier may interface to the terminal via the data access device (10) and an interface (46) to the terminal (40). In Figure 3b a dedicated terminal (50) has a slot (52) to receive the data carrier, a display (54) and controls (56). Coins can be inserted into the terminal at (58) and notes at (60) to charge the data carrier with cash.
- 30 [0072] Referring now to Figure 4a, this illustrates conceptually the logical connections and data flow between data processing systems involved in payment validation, and data download to the carrier (30). A user connects the data carrier (30) to terminal (40) and logs on to a data web page of data supply service provider (60). Either terminal (40) or service
35 provider (60) then communicates via data paths (62) with a payment validation authority (70)

to check and authorize the user's or payer's payment. In the case of electronic cash the terminal (40) may immediately validate the payment information, updating the service provider and/or payment validation authority (70) at a later stage. The logical connection (64) between the terminal and the service provider is preferably made over the internet.

5

[0073] The service provider may provide a direct portal to data providers (80) or may collect information from data suppliers (80) and provide a "front end" to present data from the suppliers to the terminal user. Alternatively, data supply service provider (60) may regulate direct access between terminal (40) and data providers (80), as shown by links (66), by communicating with the terminal and the data providers to provide communication regulation information to, for example, instruct data suppliers about what information the user of terminal (40) should have access to.

10

[0074] In a preferred embodiment, service provider (60) pays royalties at an agreed rate - for example, 10 pence per track or 10 pence per minute - to a computer system owned by a company or entity in the recording industry, such as a content provider or copyright owner, a content publisher or a content creator, and the user of terminal (40) effectively pays the service provider. Billing can also be regulated by bandwidth and/or data download time.

15

[0075] Preferably the service provider (60) monitors the user's access to the system and either stores or forwards to data providers (80), or downloads to the data carrier (30), usage information. In a preferred embodiment the service provider sends information via terminal (40) to data carrier (30) which can be used to determine incentives to be provided to users of the system.

20

[0076] Figure 4b shows a conceptual physical configuration of the system of Figure 4a in which a plurality of terminals (40), a plurality of service providers (60) and a plurality of data providers (80) all interact via the internet. The physical embodiment of the system is not critical and a skilled person will understand that the terminals, data processing systems and the like can all take a variety of forms.

25

[0077] Referring now to Figure 5, this shows a conceptual illustration of a content provision system 100. Content creators 104a, b generate or receive content data from artist terminals 102a-d and store content data in databases 106a, b. The content data stored in databases 106a, b may comprise audio data, such as music, video data, such as films or TV programs,

30

text, such as literary works, software, such as games software, or other data. Content creators 104a, b are coupled to communications network 101 for communicating created content data over the network. Also coupled to communications network 101 are content publishers 110a and 110b, each of which is coupled to an associated stored content database, 112a and 112b
5 respectively. The content publishers make their stored content available for controlled access using communications network 101. In some instances, for example where the content data comprises computer games, the functions of content creator and content publisher may be provided by a single entity. Also although conceptually illustrated as blocks in Figure 5, the content creator and content publisher typically each comprise a client server computer
10 network.

[0078] The communications network 101 is typically a private communications network, such as an extranet, with security controlled access to entities connected to the network. Physically the network may comprise an internet protocol network or it may comprise, or
15 consist of, dedicated point-to-point links. Thus, for example, a content creator 104 may be directly linked to a content publisher 110 and/or to other entities shown in Figure 5 such as a content provider or content distributor.

[0079] The content provision system includes a plurality of content providers 108a-e, each
20 coupled to the communications network 101. In the illustrated system, the content providers own copyright in stored content data accessible over communications network 101 and may, in practice, also perform a content publication function. Five content providers own the copyright in over 80% of all world-wide music sales. The content providers are coupled to stored content databases 106 and 112 via communications network 101, for supplying stored
25 content data.

[0080] A gateway server 114 is also coupled to communications network 101 to link the communications network to other networks such as the internet and/or mobile communications networks. Gateway server 114 provides security and access control
30 functions and firewalls. A second gateway, content distributor WAN gateway 116, is also shown attached to communications network 101. This provides similar security and firewall functions and coupled communications network 101 to distributor WAN (wide area network) 117. Gateway 116 has logical access to one or more of a content creator, content publisher and content provider for accessing stored content data. Content distributor gateway 116 may
35 be owned by a chain of record stores and provide content access terminals 118, coupled to

WAN 117, in separate retail outlets. Content access terminals 118 have access, via gateway 116, to stored content accessible over communications network 101.

[0081] Referring now to Figure 6, this shows a data supply computer system 120. In this embodiment, three content access terminals 118a-c, e-payment systems 121a, b, and content access web server 124 are all coupled to internet 142. Data supply system 120 is coupled to the content provision system 100 illustrated in Figure 5. Where communications network 101 of Figure 5 is an extranet, this extranet physically operates over internet 142; where communications network 101 does not partly operate via internet 142, a connection to internet 142 is established via gateway server 114 as shown in Figure 5. In this way content access terminals 118a-c are provided with controlled access to the stored content data of content provision system 100.

[0082] E-payment systems 121a and 121b are coupled to banks 122a, b and c, d respectively. These provide an e-payment system according to, for example, MONDEX, Proton, and/or Visa cash compliant standards. Preferably at least one of e-payment systems 121a, b operates a so-called "open purse" system in which the value is stored as a publicly verifiable digital signature issued by the e-payment system. In such a signature-transporting arrangement, payment data may be validated using public keys and thus payment authentication need not be performed by the e-payment system but may instead be performed by, for example, a data access terminal or data supply system computer, using payment management code. The authenticated signatures, which in effect perform a similar role to checks, are submitted to the relevant e-payment system after authentication for verification and reimbursement or transfer of monetary value. With such a system payments may be made anonymously and thus payer identification is not essential. Data carriers, such as data cards, may be issued with stored value or without value, in which latter case value (that is, a publicly verifiable digital signature) may be written onto the card during an on-line transaction.

[0083] In alternative embodiments, a data carrier such as the smart Flash card described below may be used to create value bearing digital signatures as is well-known to those familiar with e-money.

[0084] Content access web server 124 is also coupled to internet 142 for providing content access terminals 118a-c with access to content data. Content access web server 124 is typically owned by a content data supply "system owner" who acts as an intermediary

between a content access terminal user and a content provider, forwarding content data provided (directly or indirectly) by a content provider to a content access terminal and then to a stored content data carrier. Web server 124 is coupled to web server code storage 126 storing Java code for generating web pages for interpretation by web browsers on content access terminals 111a-c. The web pages provide the content download, value add, CRM (customer reward management) value check/spend and website link functions described below.

[0085] Web server 124 is coupled to payment processor 128, Digital Rights Management (DRM) processor 130, access control processor 132, and content distribution processor 134. Payment processor 128 includes payment management code storage 128a and is coupled to payment record data store 136. Access control processor 132 includes access control code storage 132a and is coupled to access control data store 138. DRM processor 130 includes DRM code storage 130a and is coupled to content access and DRM data store 140. Content distribution processor 134 includes CRM (customer reward management) and payment distribution management code storage 134a and is also coupled to content access and DRM data store 140. As shown in Figure 6, processors 128-134 are all in communication with one another.

[0086] Processors 128, 130, 132 and 134 may comprise separate application programs or a single computer program and may operate on a single physical computer, on which web server 124 may also be provided, or may operate on separate computers. Likewise data stores 136, 138 and 140 may comprise a single physical data store or may be distributed over a plurality of physical devices and may even be at physically remote locations from processors 128-134 and coupled to these processors via internet 142.

[0087] Web server 124 communicates with processors 128-134 by means of a CGI (common gateway interface) script and the code associated with processors 128-134 may be written in any conventional computer language such as C, C++, or Perl. However, in other embodiments one or more of the processors may be coupled to web server 124 via internet 142 and owned and operated by a separate entity, such as a financial institution. In this case conventional secure web-based communications may be operated between web server 124 and the relevant processor. In particular, payment processor 128 may be operated by one of the e-payment system providers 128a, b.

35

[0088] Payment management code 128a issues and authenticates payment data and stores an audit record in payment record data store 136. Access control code 132a stores identification data (of a user or card) together with registration data provided by a user when registering with the system owner. This data comprises a user password for accessing stored content and/or payment data; user characterizing data, for example characterizing user preferences, for marketing purposes; data indicating an e-payment system to use; and in some embodiments, further general user related data such as card level data for identifying the provision of "gold" level services to selected users. A copy of the password is stored with the content data on the portable data carrier, as described further below. Alternatively, one or both of the access control data store and portable data carrier may simply store data for verifying a user-entered password.

[0089] Content access and DRM data store 140 stores data related to content access and content use, but does not itself store content data items; these are instead provided via content provision system 100 described above. Data store 140 stores a plurality of records each comprising a data item identifier, a data item description, a data item type or genre, and location data comprising one or more pointers to a location or locations from where the data item can be downloaded. Associated with a data item is also a table of use rule data comprising a list of values (i.e. content data item prices) and corresponding levels of permitted usage. Thus a value of £1 might permit ten plays of a music track, while the value of £10 might permit an unlimited number of plays of the track and copying of the track for personal use.

[0090] Also associated with a data item is a table of payment distribution data comprising a list of recipients and corresponding fractions of the data item value each is to receive. Typically, the main recipient will be the copyright owner of the data item and other recipients will be selected from the content creator, the artist or artists, the system owner, the content publisher, and the retailer/distributor. The payment distribution proportions may be dependent upon the payment value, in which case a plurality of sets of payment distribution figures may be associated with each data item, each set of distribution figures corresponding to a payment value range. The payment data and distribution data is here termed DRM (Digital Rights Management) data.

[0091] Further associated with a data item is a table of CRM (Customer Reward Management) data, linked to the user rule data, comprising CRM rules to specify, for one or

more data item use levels, a quantity of reward points and one or more recipients for the reward points (the recipients may include the card user and the retailer/distributor).

5 [0092] The CRM and payment distribution code 134a operates with content access and DRM data store 140 to inform a system user of the description and value of a data item, to access and download a data item from the content provider system to a content access terminal, to provide content use rules with the data item, and to provide instructions either to payment processor 128 or to e-payment system 121 to distribute payments for the data item to the recipients identified by the data store 140 and to distribute CRM reward points.

10 [0093] The access control data store 138 holds a secure key, such as a secret "public" key in a public key cryptography system, for the system owner to authenticate its identity to a content provider. This data is held securely with other sensitive data in the access control data store 138. As is described in more detail below, when data supply system 120 receives a
15 request for a content data item from a content access terminal 118, it looks up a location from which the data item is available using content access and DRM data store 140 and then determines the identity of the corresponding content provider. This identity is either stored in content access and DRM data store 140 or, as there are relatively few content providers, it may be hard written in DRM code 130a. DRM code 130 then requests access control
20 processor 132 to provide the secure system owner identifier from access control data store 138 to the relevant content provider and sets up a trusted connection between the content provider and content access web server 124 for downloading the data item to a content access terminal 118 and then to a portable data carrier.

25 [0094] Referring now to Figure 7, this shows a variety of content access terminals for accessing data supply computer system 120 over internet 142. The terminals are provided with an interface to a portable data carrier or "smart Flash card" (SFC) as generally described with reference to Figure 2 and as described in more detail below. In most embodiments of the terminal the SFC interface allows the smart Flash card data carrier to be inserted into and
30 removed from the terminal, but in some embodiments the data carrier may be integral with the terminal.

[0095] Referring now to the specific embodiments illustrated in Figure 7, a simple content access terminal may comprise a home personal computer 144 with SFC interface 144a. In
35 another embodiment, a mobile communications device 152 is provided with a smart Flash

card interface 152a and is coupled to internet 142 via radio tower 150, mobile communications system 148 and mobile communications internet gateway 146.

5 [0096] In another embodiment, a smart Flash card interface is provided to a so-called "set top box" (STB) 154. The set top box is, in effect, a receiver for television programs received on video input 154b, which may comprise a satellite TV signal, a cable TV signal or an off-air TV signal. The video signal is provided from the set top box to television 156 or to some other home entertainment device such as a personal computer (not shown). In another
10 embodiment, content access terminals 166 and 168 each with respective SFC interfaces 166a and 168a are coupled to a retailer local area network (LAN) 160 connected to internet 142 via retailer LAN server 158. DVD player 164 is also coupled to LAN 160. In a further embodiment a smart Flash card interface 170a is provided for a CD/DVD player 170.

15 [0097] In these latter three embodiments, content data for storage on the smart Flash card may be retrieved from broadcast video and/or a CD or DVD. In this case, the computer data supply system 120 illustrated in Figure 6 may be used to provide use rule data for the content data stored on the smart Flash card, and to pay for data downloaded onto the card; the content data may be captured before or after the data supply system 120 is accessed to enable use of the stored data, but in a preferred embodiment content data written to the card from a supplier
20 other than the content data supply computer system is not accessible to a user until corresponding use rule data has been downloaded from computer system 120, which will normally be after receiving payment for the downloaded data.

25 [0098] Referring now to Figure 8, this shows a schematic diagram of one embodiment of a data access terminal 170. The terminal comprises a general purpose computer including an audio/visual interface 184, a keyboard 186 and a pointing device 188 for providing an interface to the user. The terminal has an internet interface 176, for example a modem, and optionally a LAN/WAN interface 174 for connecting the terminal to a retailer or distributor LAN or WAN. The terminal also has an optional video input 178 for receiving broadcast
30 video data and a media input device 180, such as a CD or DVD drive. Further communications I/O ports 182 may also be provided. A portable data carrier or smart Flash card interface 190 is provided for interfacing to a smart Flash card. Optionally, a cash input and verification system 192, such as is conventionally used in an automatic teller machine (ATM), may also be incorporated within the content access terminal. The terminal has
35 working memory 194 such as RAM and program memory 196 which can comprise any

conventional storage device such as RAM, ROM or a disk drive. Program code in program memory 196 may also be stored on removable disk 198. A processor 200 loads and implements program code stored in program memory 196. All the components of the terminal are linked by a data and communications bus 172.

5

[0099] More specifically, processor 200 loads and implements cash payment management code 200a for managing cash input data from cash input and verification system 192, for adding value to a smart Flash card. Processor 200 also implements a web browser 200b for accessing system owner web pages and data exchange interface 200c for exchanging data

10

between a smart Flash card interface to the terminal and data supply system 120.

[0100] Processor 200 also implements off-line contents retrieval code 200d for retrieving data for storage on a smart Flash card from media input device 180 and/or video input 178 and/or LAN/WAN interface 174. The processor implements a content sampler 200e for

15

outputting small extracts of content data items to a user via audio/visual interface 184. Such data item samples may be stored with the content description data in content access data store 140. The processor also implements a smart Flash card interface driver 200f, user interface code 200g and additional communication drivers 200h for driving LAN/WAN interface 174 and/or comms I/O ports 182.

20

[0101] Referring now to Figure 9, this shows a schematic diagram of components of a portable data carrier 202, in the embodiment shown a so-called "smart Flash card". In this context, "smart Flash card" refers to an IC card similar in size to a plastic payment card incorporating a processor and Flash data memory, preferably of large capacity. For further

25

details on smart cards, reference may be made to the ISO (International Standards Organization) series of standards, including ISO 7810, ISO 7811, ISO 7812, ISO 7813, ISO 7816, ISO 9992 and ISO 10102, which are hereby incorporated by reference.

30

[0102] Referring in more detail to Figure 9, a data and communications bus 204 links components of the card which include a processor 210, working memory 212, timing and control logic 208 and an external interface which may have contacts (ISO 7816) or be contactless (ISO 10536) for providing external access to a bus 204 for reading data from and writing data to the card 202. Also coupled to bus 204 are permanent program memory 216, non-volatile data memory 218 and non-volatile (Flash) content data memory 214. Non-

35

volatile data memory 218 may comprise EEPROM and permanent program memory 216 may

comprise ROM, for example, mask-programmed ROM. All the components of Figure 9 are mounted on a single substrate, in a preferred embodiment bearing contacts for external interface 206.

- 5 [0103] Processor 200 loads and implements program code from permanent program memory 216. This code comprises operating system code for providing the card with a basic operating system for at least external communications; payment management code for supplying payment data from non-volatile data memory 218 to pay for downloaded content; DRM (Digital Rights Management) and security code, including code to implement content
- 10 data use rules and code for password controlled access to data and program functions; CRM code for implementing CRM-related rules; and content synthesis code for combining stored content data with additional data provided via external interface 206 for synthesizing complete content item data.
- 15 [0104] Non-volatile data memory 218 stores data including card identity data, access control data, including password data for validating a user password, access record data for storing a record of access attempts and their outcomes, and content supply data such as system owner website addresses and retailer/distributor website addresses.
- 20 [0105] Data memory 218 further stores card value data comprising e-money such as publicly verifiable digital signatures, and payment data for storing a payment audit trail including payment amounts and data on to whom payments have been made. The memory 218 also stores RFM (Recency Frequency Monetary) data to provide a record of transactions for market research and customer reward purposes, and CRM data storing customer reward
- 25 points. Data memory 218 also stores an index of content data items stored in Flash memory 214 and associated content use rules, as well as DRM and royalty data for maintaining an audit trail of use history for rights management tracking. Optionally, data memory 218 may also store supply chain data specifying a supply chain route through which data has been obtained from a content provider, which may be used for rewarding supply chain
- 30 intermediaries, for example on a commission or reward points basis.
- [0106] Content data memory 214 preferably comprises at least 100 MB of data storage, partitioned as data blocks of a size selected to match the stored content type. For storing video data, Flash memory 214 preferably comprises > 1 GB data storage and the data blocks
- 35 into which the data memory is partitioned are larger.

[0107] Referring now to Figure 10, this shows a schematic diagram of a data access device 220, such as a portable audio/video player. The data access device 220 comprises a conventional dedicated computer system including a processor 238, permanent program
5 memory 236, such as ROM, working memory 234, such as RAM, and timing and control logic 226 all coupled by a data and communications bus 222. Also coupled to the bus are an audio interface 228, a display 230 and user controls 232, for providing a user interface. A smart Flash card interface 224 is coupled to bus 222 for interfacing with a smart Flash card for retrieving and playing stored content data.

10 [0108] Permanent program memory 236 stores program code for implementation by processor 238; this code may also be provided on a data carrier such as a ROM chip or disk 240. Processor 238 implements an SFC interface 238a, a user interface 238b, a content player 238d for retrieving stored content data from a smart Flash card interfaced to the device
15 and for outputting audio and/or video data derived from the retrieved content data (which may comprise compressed audio and/or video data) to a user of the device.

[0109] Processor 238 also implements use control 238c for controlling access to and use of contents stored on the smart Flash card by the content access device user. Use control routine
20 238c and/or DRM and security code in permanent memory 216 on the smart Flash card may also implement digital watermarking and other Secure Digital Music Initiative (SDMI) content protection code as specified in the SDMI portable device specification, part one, version 1.0 (see www.sdmi.org) which is hereby incorporated by reference.

25 [0110] Figures 11a and 11b show a flow diagram of a process for registering a data carrier or smart Flash card with a data supplier or system owner operating a data supply system as illustrated in Figure 6. A smart Flash card may be issued entirely blank, that is, with no prestored content or value, with prestored value but no prestored content, with prestored
30 content but not prestored value (the content being provided free) or with both prestored value and prestored content. Thus, for example, a user may purchase a card with stored value but no stored content over the counter at a retailer. The process of Figures 11a and 11b illustrates the registration of a card with neither prestored content nor prestored value. As illustrated the registration process records user registration data in the access control data store 138 of
35 Figure 6 and writes value data onto the blank card.

[0111] At step S10 a smart Flash card is inserted into a content access terminal smart Flash card interface. The system owner web page is then loaded onto the content access terminal and displayed to the user (step S11). User registration data is then entered into the content access terminal (step S12) and transmitted to the system owner (S13). The user registration data may include a user identity, a preferred e-payment system to use and, optionally, a content access PIN or password, and a service level (for example bronze, silver or gold). The optional password may be a password required by the e-payment system for validation of a payment by the user with the card or it may be a password to protect unauthorized access to content on a smart Flash card to protect stored data in the event, for example, of the card being stolen. A single password may serve both these functions. The content access terminal web browser is configured so that all sensitive data passing between the terminal and the system owner is securely transmitted, for example by using a conventional encryption system such as PKI (Public Key Infrastructure).

[0112] At step S14 a payment request is received from the system owner at the content access terminal and displayed to the user. At step S15 the user enters payment data into the content access terminal and this payment data is transmitted to the system owner, for adding value to the card. This may, for example, be a credit card transaction as is conventionally used for purchase over the internet. Card value data and a card value access code is then received by the content access terminal from the system owner at step S16. The card value corresponds to the payment made by the user and the value access code may be a password entered by the user at step S12 or may comprise a password for PIN created by payment processor 128 or e-payment system 121 as illustrated in Figure 6. In a preferred embodiment, the user pays the system owner and the system owner then directly provides digital signature data representing value to the content access terminal for writing onto the smart Flash card.

[0113] At step S17, card registration data is received from the system owner by the content access terminal and written onto the smart Flash card. This card registration data comprises user identity data, access control data, payment system specifying data, system owner access data, such as a system owner web page address and other dial-up information. At this stage other data may be entered by the user and written onto the card, including, for example, user preference data, retail outlet and CRM data (alternatively user preference data may be captured at step S12). At step S18 the card value data and card value access code received at

step S16 is written onto the card and output to the user visually and, optionally, as a printed record. The card is then available for use, at step S19.

[0114] Figure 11b shows the corresponding registration steps performed by the system owner's data supply system 120. At step S20, a request for a smart card registration web page is received from a content access device and, at step S21, transmitted to the device. User registration data is then received, at step S22, from the content access terminal and stored in content access control data store 138. The system owner's computer system then transmits, at step S23, a payment request to the content access terminal and receives, at step S24, payment data in reply, this payment is then authenticated, at step S25, with an e-payment system such as payment system 121 a or b illustrated in Figure 6, and after verification the payment processor 128 of the computer system transmits, at step S26, value data and a value access code to the content access terminal, for writing onto the smart Flash card. The payment processor then updates the payment record data store 136 with data relating to the transaction (step S27) and, at step S28, retrieves card registration data previously written into the access control data store and transmits this registration data to the content access terminal. At step S29 the transaction is then complete.

[0115] Referring now to Figures 12a-c, these illustrate a flow chart for downloading data to a smart Flash card using a data access terminal. At step S30 the smart Flash card is inserted into the content access terminal and the user then enters, at step S31, their password for gaining access to the functionality of the smart Flash card. At step S32, the content access terminal transmits the password to the smart card for verification and the terminal checks, at step S33, whether access is permitted. If access is not permitted a warning is displayed by the terminal, at step S34, and an access denied count is implemented. A threshold count is then read from the card together with a count of the total number of times access to the card has been denied (step S35). At step S36 the terminal checks whether the total number of denied accesses is within three of the card threshold, and if it is not, returns to step S31, while if it is, it proceeds to step S37 where the terminal displays a warning that a further denied access is likely to result in erasure of content stored on the card. At step S38 the terminal then checks whether its count of denied accesses is greater than its threshold value, returning to step S31 if not, and displaying an access refused message at step S39 if the total number of permitted accesses has been exceeded. The system then waits at step S39 for removal of the smart Flash card from the content access terminal.

[0116] If access is permitted at step S33, the terminal loads outline CRM data from the card (step S40) and loads retail data, such as targeted advertising, from the retailer LAN/WAN (step S41). At step S42, the terminal then displays a menu of options, retail data such as
5 advertising or CRM-related data and outline CRM data, such as a total number of reward points earned, on the content access terminal. Many options include download content (from a system owner), add monetary value (to the card), check/spend CRM value stored on the card, follow website links, and exit. At step S43, the user inputs a menu option which, in the illustrated flow chart, is the download option. The system thus passes to step S44 and loads
10 the system owner's content access web page onto the content access terminal and displays this to the user.

[0117] At step S45, the user enters a content search request, which is transmitted to the system owner content distributor processor 134. Content search results are received back
15 from the content distribution processor, including a content identifier, a brief description, and content cost data for at least one payment option, and these results are displayed on the user on the content access terminal. The user then selects one or more content items at step S47 and the selection is transmitted to the content distribution processor 134 where further content cost data and purchase option data is retrieved from data store 140. At step S48, this
20 content cost and purchase data (including use rule data) is received from the system owner and displayed to the terminal user. The user then selects, at step S49, a purchase option and confirms a purchase request or, alternatively, selects "exit" to return to the menu display of step S42. After one or more content items have been selected, together with a purchase option, hard value and CRM data is read from the smart Flash card at step S50, and at step
25 S51 a check is made to determine whether the monetary and/or CRM (reward points) value stored on the smart Flash card is sufficient to purchase the selected purchase data items. If the card value is insufficient, a warning is displayed at step S52 and the system returns to the menu display at step S42. If the card value is sufficient, at step S53 the content access terminal transmits a payment request to the smart Flash card.

30 [0118] Payment for the data item or items requested may either be made directly to the system owner or may be made to an e-payment system such as e-payment systems 121a and 121b of Figure 6, with these systems then forwarding payment confirmation data to the system owner computer system. Alternatively, the content access terminal may transmit data

to the card to set up a transaction directly with a content provider who, being the copyright owner, would normally receive the majority of the payment.

5 [0119] At step S54, payment data for making a payment to the system owner is received from the smart Flash card by the content access terminal and forwarded to an e-payment system such as e-payment system 121 in Figure 6. Payment record data, validating payment by the card to the system owner, is then received back from the e-payment system at step S55 by the content access terminal and forwarded to the card for updating payment data on the card. In alternative embodiments, payment data from the card may be provided directly to the system owner's data supply computer for authentication and, optionally, further validation with an e-
10 payment system by the system owner's computer.

[0120] Distribution of the payment received by the system owner from the card is performed by the system owner's computer system, as described elsewhere. Such payment distribution
15 will normally provide a small percentage of the total payment to a "owner" or operator of the content access terminal, such as a retailer, distributor, or in other embodiments, mobile communications network operator or cable TV network operator.

[0121] In the presently described embodiment, payment record data received in step S55 is
20 transmitted to the system owner to confirm payment by the card and thus it is the content access terminal, in the described embodiment, which authenticates a payment before confirming that the payment has been made to the system owner.

[0122] In step S56, together with the payment record data, purchase request and card
25 registration data is transmitted to the system owner to identify one or more content data items for purchase and to identify the purchaser. Then, at step S57, the content access terminal sets up a transaction between the system owner data supply computer and the smart Flash card for download of the identified content items requested from the data supplier to the smart Flash card. The download is preferably arranged so that there is no permanent storage of
30 downloaded data on the content access terminal (although temporary storage in a disk cache may be permissible), and there is further preferably no temporary storage on the content access terminal of complete data for a content data item. This provides data security and reassurance to the content providers.

[0123] In the same way as with card registration described with regard to Figure 11, a secure and trusted link is set up between the content access terminal and/or the smart Flash card and the data supply computer in a conventional manner as is well known to those skilled in the art (for example, using public key data encryption). The data transaction may be set up directly
5 between the smart Flash card and the data supply computer, in which case the content access terminal has no access to unencrypted content data, or it may be set up between the content access terminal and the data supply computer, in which case unencrypted data is written by the content access terminal to the smart Flash card. Standard transmission protocols are used to ensure complete transmission of a content data item, for example by re-transmitting blocks
10 of data which are not correctly received.

[0124] Also at step S57, one or more content access rules is received from the system owner data supply computer and written to the smart Flash card so that each content data item has an associated use rule to specify under what conditions a user of the smart Flash card is
15 allowed access to the content data item.

[0125] At step S58 the content access terminal receives CRM data from the content distribution processor 134 of the system owner, for example specifying a number of reward points earned by downloading the selected content items. This CRM data will normally be
20 written to the smart Flash card (step S59), but may additionally or alternatively be stored in the content access terminal or in a data store of the content access terminal owner so that the reward points are held by the distributor/retailer/cable TV operator. Finally, also at step S59, a complete record of details of the transactions between the smart Flash card and the content access terminal, the smart Flash card and the system owner, the smart Flash card and the e-
25 payment system, and the content access terminal and the e-payment system and/or data supply computer is recorded on the smart Flash card to provide an audit trail. The system then returns to the menu display at step S42.

[0126] The add monetary value menu option provided by the menu operates in a similar
30 manner to that described with regard to steps S15 and S16 of Figure 11a and steps S24 to S27 of Figure 11b. In embodiments of the system in which the smart Flash card operates either in a debit (pre-pay) or credit mode, operating mode data may be loaded from the card together with outlying CRM data at step S40. If the card is operating in a credit mode then, at step S41, the content access terminal reads content use data records from the card and proceeds
35 correspondingly to steps S47 and S48 to determine the value of the content accessed and then

proceeds according to steps S15 and S16 of Figure 11a and steps S24 to S27 of Figure 11b to retrieve payment for the accessed content from the card owner. Where enhanced access control features are provided, access control data read from the smart Flash card or entered into the content access terminal at step S31 is used, in step S44, to access the system owner content access webpage and, in some embodiments, to set up a secure connection between the content access terminal and system owner data supply computer at step S44.

[0127] Referring now to Figures 12d and 12e, these show steps in a process implemented on the system owner's data supply computer for providing content data to a content access terminal and thence to a data carrier such as a smart Flash card. At step S60 the system owner's content access web page is requested by a content access terminal and transmitted to the requesting terminal. A search request for searching for a content data item is received, at step S61, from the content access terminal, and at step S62 content distribution processor 134 of the content supply system searches content access and DRM data store 140 and transmits the search results to the content access terminal. The search results will normally comprise a content item identifier, a content item description, optionally a content item sample, and at least one content item price, for example for a default payment option. The search results may comprise a set of content data items, either selected by type or artist or comprising some predetermined selection in a similar manner to a compilation of tracks on a CD.

[0128] At step S63 content item selection data identifying one or more content items is retrieved from the content access terminal, and at step S64 content item purchase data for the selected content items is retrieved from content access and DRM data store 140. This purchase data will normally include, for each selected content item, one or more prices and purchase options. Purchase option data may simply comprise one of a set of standard options, for example "1" to purchase outright, "2" to rent for a period of time, "3" to rent for a number of plays, and "4" to rent with a final purchase option. The purchase option data may also indicate when a content item is available free.

[0129] At step S65 the content purchase data is transmitted to the content access terminal, and at step S66 payment record data, indicating a payment made from the smart Flash card to the system owner, purchase request data, card registration data and, optionally, access control data, is received from the content access terminal. The payment record data confirms a payment for the requested data items, the purchase request data specifies the payment option selected for the selected content items, and the card registration data provides data for

keeping records of the transaction and providing reward points; the access control data may be required for additional data security. At step S67 the payment record data, in the described embodiment of the system, is validated with an e-payment system such as e-payment system 121 of Figure 6. As illustrated in the flow chart, the data supply system computer checks with the e-payment system that a payment has in fact been made to the system owner. In other embodiments of the system, payment may be made directly to the system owner, and either concurrently with the content access and download process, or at some later stage, payment data received from the smart Flash card may be verified with the e-payment system for reimbursement of the system owner.

10

[0130] At step S68, payment distribution data is read from the content access data store 140. This data will indicate how payment made by the card for the data is to be distributed among recipients. In one embodiment, recipients' payment fractions are specified in general terms in the content access data store, for example copyright owner 0.90, system owner 0.01, retailer/distributor 0.02, publisher 0.02, creator 0.05. Identification of who is the relevant copyright owner is stored in the data store together with the content item identifier, but may be selected from more than one possible content provider for the data item, and identification of who is the relevant retailer/distributor may be determined from, for example, content access identity information received from the content access terminal when the system owner content access web page is accessed at step S60. At step S69, payments are then distributed in accordance with the payment distribution data, either by direct distribution of value-bearing digital signatures to the relevant parties, or by issuing a payment distribution instruction to e-payment system 121. Preferably the data supply system stores records of individual card payments and, at intervals, combines the payment distribution data for a plurality of individual records to output payment data for distributing the total payment received by the data supply system from a batch of individual payments.

20

[0131] At step S70, content access rules for the purchased level of service are read from the content access data store. These rules could, for example, specify that only a predetermined number of accesses to the content are permitted, for example 10 plays. Alternatively, the rules could provide access for, say, one month from the download date. Other rules may provide unlimited plays but only on specified players, for example set top boxes owned by a particular cable TV network (as determined by content access device identification data provided to a smart Flash card from a content access device). A content provider

30

identification for the requested content data is also read from the content access data store at step S70 together with CRM data for issuing reward points.

5 [0132] At step S71, content access rules for the requested content data items are retrieved from data store 140 and transmitted to the content access terminal. Then, at step S72, DRM processor 130 of the data supply system transmits a transaction request and authentication data to the content provider identified in step S70. This request identifies the system owner data supply system to the content provider in a secure manner, either by means of physical security, such as a dedicated connection from the system owner data supply system to the
10 content provider, or by means of an electronically secure connection such as an encryption connection. Then, at step S73, the content access web server 124 receives protected content from the content provider, comprising the data items requested by the content access terminal, and transmits this protected content to the content access terminal. The content is preferably protected by data encryption but may be protected in other ways, for example, by
15 digital watermarking or simply by the large number of other transactions taking place at any one time over the internet. The data supply system computer, at this point, essentially acts as a transparent data forwarder, forwarding data from the content provider to the content access terminal, which itself is preferably effectively transparent, using data exchange interface 200c to transmit the protected content data directly to the smart Flash card. As described with
20 regard to Figure 12d, the content download protocol includes error protection and transmission retry protocols to ensure substantially error-free data transmission.

[0133] Once content has been downloaded to the content access terminal (and, hence, to the smart Flash card) at step S74 a record of the purchase data and content accessed is written to
25 payment record data store 136, to provide an audit trail. Then, at step S75, updated CRM data is written to the content access data store 140, using rules stored in the content access data store, in conjunction with a record of the downloaded data items, to calculate the CRM data (i.e. reward points). The updated CRM data is then also transmitted to the content access terminal, where it can be forwarded to the smart Flash card. Then, at step S76, the
30 process ends.

[0134] Referring now to Figure 13, this shows a flow chart for user access of stored data on a smart Flash card using a data access device such as the MP3 player of Figure 1. At step S77 the smart Flash card is inserted into the player and, at step S78, the user enters a password
35 into the player, which is transmitted to the smart Flash card for validation (this step is

optional). If access to stored data on the card is permitted, the process proceeds to step S79 where an index of content data items stored on the card is loaded from the card and displayed together with a menu. The menu provides options including access content, check value (stored on the card), check CRM data (such as reward points) stored on the card, and play options (such as no video, repeat play, random play, and the like). If the user wishes to access content data items stored on the smart Flash card, a user selection of such items is entered into the player at step S80, for example using cursor keys or a pointer; additionally or alternatively a default play option may be provided to, for example, play the most recently downloaded data.

10 [0135] At step S81 content use status data for the selected content items is loaded from the smart Flash card together with associated content use rules. Then, at step S82, the use rules and present use status for each selected content item are compared and the result is displayed together with a content play menu. The content play menu may comprise a simple list of the
15 selected content items with items not available for access highlighted in, for example, red. Alternatively, more detailed content access permission data may be displayed such as the purchased contents use for a content data item, the actual use of the data item made so far, and the available remaining use. Then, at step S83, the player determines whether content use is permitted. If use is not permitted, the process returns to step S79 to re-display the
20 menu; if content use is permitted the system proceeds to step S84.

[0136] At step S84 the selected content data items whose use is permitted are retrieved sequentially from the card, decoded as necessary, and the decoded audio and/or video data is made available to the user, for example, by providing audio output at a headphone socket on
25 the player and displaying video output on the player display. Preferably, the player also retrieves supplementary data stored in association with a content data item, such as advertising data, or for a web-enabled player, hot links to web sites for sale of goods or services, particularly those related to the accessed content data item or those identified to appeal to users accessing the data item (such as pop group merchandizing or Harley Davidson
30 (trade mark) motor bikes for rock music/video).

[0137] Preferably, the player is provided with "pause" and "continue" functions and corresponding user controls. When "pause" is selected the process passes to step S85 and writes a record to the smart Flash card comprising data specifying how much use has been
35 made of the accessed content data item. In the case of music or video data, this may

comprise start and end time markers or simply a play duration time (the start time being predetermined, for example at the start of the data item). In the case of a game the partial use data may comprise an elapsed play time or a number of lives left. In the case of a data item providing a service such as access to stock and share prices, or weather information, or a share dealing service, the partial use information may comprise a status record indicating the status of an interrupted transaction. When the "continue" function is selected on the player the process returns to step S84.

[0138] To allow for the smart Flash card being removed from the player between pause and continue events, a check may be made at step S78, by reading a partial use status data from the card, to determine whether a content data item was left in a pause state when the card was last used. If such a pause state is determined to exist for a content data item, the process may then jump directly to step S85 to allow a user to resume or continue with the content data item and proceed directly to step S84.

[0139] Once play is complete the process moves to step S85 where updated content use data is written to the smart Flash card. This updated use data provides a record of the use of a content made in step S84. This record can then be used in steps S81 to S83 to determine, on a subsequent occasion, whether further use of the content data item is permitted. Finally, at step S86, customer reward management reward rules are loaded from the smart Flash card together with CRM data stored on the card. The CRM data is then updated, using the CRM reward rules, to reflect the use of content data items made in step S84 and the updated data is written back to the smart Flash card.

[0140] In one embodiment the CRM reward rules are determined by the content access terminal owner (retailer/distributor/cable or mobile network operator) and are written onto the card when registering the card. The updated CRM data may then be accessed by a content access terminal for spending or other use when the smart Flash card is next inserted into a content access terminal. Once the CRM data has been updated, the process returns to step S79 to display the content index and menu.

[0141] The specific embodiments of the invention described above use communication over the internet and web-based technology but this is not essential, and the invention may be implemented using any electronic communications network, such as a wide area network, local area network, wireless network, or conventional land line network. Likewise, the

invention is applicable to the internet, intranets, extranets, and other internet protocol networks.

[0142] The skilled person will understand that many variants to the system are possible and
5 the invention is not limited to the described embodiments but encompasses modifications
which lie within the spirit and scope of the present invention.

60881106 v1

COMPARISON COPY

WQ-01/31599

PCT/GB00/04110

Attorney Docket 80379-000100US
Client Ref. F/USP81421X**SUBSTITUTE SPECIFICATION****DATA STORAGE AND ACCESS SYSTEMS****Background of the Invention**

[0001] This invention is generally concerned with data storage and access systems. More particularly, it relates to a portable data carrier for storing and paying for data and to computer systems for providing access to data to be stored. The invention also includes corresponding methods and computer programs. The invention is particularly useful for managing stored audio and video data, but may also be applied to storage and access of text and software, including games, as well as other types of data.

~~Once~~**[0002]** One problem associated with the increasingly wide use of the internet is the growing prevalence of so-called data pirates. Such pirates obtain data either by ~~unauthorised~~ unauthorized or legitimate means and then make this data available essentially world-wide over the internet without ~~authorisation~~ authorization. Data can be a very valuable commodity, but once it has been published on the ~~Internet-internet~~ it is difficult to police access to and use of it by Internet users who may not even ~~realise-realize~~ that it is pirated. This is a particular problem with audio recordings, and, once the bandwidth becomes available, is also likely to be evident with video.

[0003] Over the past three or four years compressed audio sources have become increasingly widely available on web pages. One widely used audio data compression format is MP3 (MPEG - Audio Layer 3) of the MPEG1 compression algorithm, which is an internationally defined standard including a definition of compressed audio information such as speech or music. It relies on psycho-acoustic properties of human hearing to achieve very large data compression factors. It is thus feasible to download usefully long passages of music in a practically convenient short time. Pirate data suppliers have not been slow to ~~realise-realize~~ the potential of this, and many ~~unauthorised-unauthorized~~ websites have sprung up offering

popular music, including recent releases by world -famous bands. This has caused the recording industry considerable concern and there is an urgent need to find a way to address the problem of data piracy.

~~The invention described below addresses this and related problems.~~

Summary of the Invention

[0004] According to the present invention there is therefore provided a method of providing portable data comprising providing a portable data storage device comprising downloaded data storage means and payment validation means; providing a terminal for internet access; coupling the portable data storage device to the terminal; reading payment information from the payment validation means using the terminal; validating the payment information; and downloading data into the portable storage device from a data supplier.

[0005] Another aspect of the invention provides a corresponding mobile data retrieval device for retrieving and outputting data such as stored music and/or noise from the data storage device.

[0006] The payment validation means is, for example, means to validate payment with an external authority such as a bank or building society. The combination of the payment validation means with the data storage means allows the access to the downloaded data which is to be stored by the data storage means, to be made conditional upon checked and validated payment being made for the data. Binding the data access and payment together allows the legitimate owners of the data to make the data available themselves over the internet without fear of loss of revenue, thus undermining the position of data pirates.

[0007] A further advantage of the system is that it allows users under the age of 18 to make internet purchases. Currently internet users pay for goods and/or services by credit card. Since credit cards cannot be legitimately be used by persons under the age of 18 (at least in the UK), a significant fraction of adventurous internet users are excluded from e-commerce, one of the most significant predicted uses of the internet. In one embodiment of the invention, however, the payment validation means comprises e-cash-; that is, the payment validation means stores transaction value information on a cash value of transactions validatable by the data storage means. In simple terms, the data storage means can be a card which is charged up to a desired cash value (if necessary limited to a maximum value) at a

suitable terminal. This might be an internet access terminal but could, more simply, be a device to accept the data storage card and to receive and count money deposited by the user to charge the card, writing update cash value information onto the card. More sophisticated ways of updating the cash value on the card are also possible, such as direct bank transfer. Since, with this type of embodiment, the data storage means is, essentially, precharged with cash rather than acting as a credit card, it can be used by young people without the risk of their incurring large debts.

[0008] In one embodiment the data storage means is powered by the retrieval device when it is connected to the device and retains a memory of the downloaded data when it is unpowered. This can be achieved by the use of Flash RAM or, more generally, any form of programmable read-only memory. Alternatively the data storage means may incorporate a rechargeable cell or capacitor and store information in battery backed-up static RAM.

[0009] The downloaded data ~~maybe~~ ~~may be~~ entered into the data storage device by means of an interface such as a magnetically or capacitatively coupled connection or an optical connection, but preferably the interface comprises contacts for direct electrical connection to the storage means. The payment validation means may likewise have one of a variety of interfaces but again preferably comprises a set of electrical contacts. The payment validation means could, however, comprise a magnetic or holographic data-strip such as is known for use with credit cards and phone cards. The interface to receive the downloaded data may be separate from the interface to the payment validation means, to facilitate separate and simultaneous access to both these systems. In other embodiments a single interface may serve for both data storage and payment. Advantageously the payment validation means includes a memory storing information to identify the person who is paying for the downloaded data.

[0010] For additional security the downloaded data may be encrypted. In this case data decryption may be necessary at some stage, either in the data storage means or in the retrieval device or in an information delivering apparatus such as a data access terminal. Alternatively the data decryption function can be shared amongst one or more of these devices. The skilled person will be aware of a range of suitable encryption/decryption techniques, including Pretty Good Privacy (Registered Trade Mark) and PKI (Public Key Infrastructure). Normally when the downloaded data is encrypted a decryption key must be supplied. This can be generated

automatically by the data access terminal or data access service provider or it can be entered by the user into the data access terminal or into the mobile data retrieval device.

[0011] The data storage means and/or the retrieval device can be provided with access control means to prevent ~~unauthorised~~ ~~unauthorized~~ access to the downloaded data. Additionally or alternatively, use control means can be provided to stop or provide only limited access of the user to the downloaded data in accordance with the amount paid. These access and use control functions may in some embodiments be combined, permitted use controlling access or permitted access controlling use. Thus, for example, a complete set of data information relating to a particular topic, a particular music track, or a particular software package might be downloaded, although access to part of the data set might thereafter be controlled by payments made by a user at a later stage. In this way, a user could pay to enable an extra level on a game or to enable further tracks of an album.

[0012] In embodiments where the access or use control means is responsive to the payment validation means, access or use control information may be stored with the downloaded data or in a separate storage area, for example in the payment validation means. The user's access to the downloaded data could advantageously be responsive to the payment validation means, for example, by means of a control line coupling the payment validation means with a memory access or decryption control element.

[0013] In one embodiment the data storage means comprises an electronic memory card or smart card and the mobile data retrieval device is provided with a slot to receive the card. Preferably the card is a push-fit within the retrieval device, and retention of the card may be effected by pressure from electrical interface connections and/or resilience of the housing, or by using a resilient retaining means. In a preferred embodiment the retrieval device includes an audio output and a display, to play a downloaded track and to show information about the track and/or an accompanying video.

[0014] To download data onto the data storage means the user can employ a data access terminal coupled to the internet. The terminal can directly validate payment—; for example in the case of a smart card charged with electronic cash it can deduct a cash value from the card. Alternatively it can communicate with a bank or other financial services provider to control payment. In a preferred embodiment, however, the terminal connects to a data access service

provider which provides a portal to other sites and which validates payment and then forwards data from a data supplier to the user's local access terminal. The data access service provider may alternatively forward payment validation information and/or information from the payment validation authority to the data supplier for control by the supplier of the data supplied. Thus, access to the payment validation system and/or data for downloading may be entirely controlled by the data supplier.

[0015] Data held on the data storage means may advantageously include data relating to the user's or payer's usage of the system. This information may include, for example, information on a user's spending pattern, information on data suppliers used and information on the downloaded data. This information may be accessed by the data supplier and/or data access service provider and can be used for targeted marketing or loyalty-based incentive schemes such as air miles or the like.

[0016] The data access terminal may be a conventional computer or, alternatively, it may be a mobile phone. Wireless Application Protocol (WAP) and i-mode allow mobile phones to efficiently access the internet and this allows a mobile phone to be used to download data to the data storage means, advantageously, directly. The data storage means can, if desired, incorporate the functionality of a mobile phone SIM (Subscriber Identity Module) card, which cards already include a user identification means, to allow user billing through the phone network operator.

[0017] In a preferred embodiment the downloaded data is MP3 or other encoded audio data, but the system finds more general application for other data types. For example, download data can include software, and particularly games, share price information, current news information, transport timetable information, weather information and catalogue catalog shopping information. The downloaded information may also include compressed video data. The storage capacity of the data storage means is adaptable to suit the type of data intended to be downloaded; for example, 32 megabytes is sufficient for CD quality music, but for video it is preferable that the data storage means has a capacity of 128 megabytes or greater.

[0018] In another aspect, the invention provides a portable data carrier comprising an interface for reading and writing data from and to the carrier; non-volatile data memory,

coupled to the interface, for storing data on the carrier; non-volatile payment data memory, coupled to the interface, for providing payment data to an external device.

[0019] These features allow the data carrier to store both payment data and content data, thus providing the advantages outlined above. Depending upon the payment system used, the payment data memory may also store code for validating or confirming a payment to an external payment system. The payment data will normally be linked to a card or card holder identification data for payment by the card holder. The non-volatile memory ensures that stored content and payment data is retained in the data carrier when the data carrier is not receiving power from an external source. Thus "non-volatile" encompasses, for example, low-power memory whose contents are retained by a battery back-up system. In one embodiment the payment data memory comprises EEPROM and the content data memory comprises Flash memory, but other types of content data memory, such as optical, for example, holographic, data memory can also be used. The data carrier may also be integrated into other apparatus, such as a mobile communications device.

[0020] Preferably, the portable data carrier further comprises a program store for storing code implementable by a processor; and a processor, coupled to the content data memory, the payment data memory, the interface and to the program store for implementing code in the program store, wherein the code comprises code to output payment data from the payment data memory to the interface and code to provide external access to the data memory.

[0021] Normally, the (content) data memory allows both write and read access for both storing and retrieving data, but in some embodiments the content data memory may be read-only memory (ROM). In such embodiments, content may be pre-loaded onto the carrier and payment may then be made for permission to access the pre-loaded data.

[0022] Preferably, the data carrier also stores a record of access made to the content data and updates this in response to external access, preferably read access, made to the data memory. The carrier may also store content use rules pertaining to allowed use of stored data items. These use rules may be linked to payments made from the card to provide payment options such as access to buy content data outright; rental access to content data for a time period or for a specified number of access events; and/or rental/purchase, for example where rental use

is provided together with an option to purchase content data at the reduced price after rental access has expired.

[0023] Thus where the data carrier stores, for example, music, the purchase outright option may be equivalent to the purchase of a compact disc (CD), preferably with some form of content copy protection such as digital watermarking. In this example, the rental or subscription payment option may be a pay-per-play option, and with this option payment may either be before or after access to the stored data so that the carrier may operate in either a debit or credit payment mode.

[0024] The portability of the data carrier potentially allows it to be used to access content or, in the example, play music without the need to be linked to a communications system or to be on-line to the internet. By providing a use record memory on the data carrier, use of the stored data can be tracked ~~whilst~~while off-line and then any necessary payment can be made when the data carrier is next coupled to a communication system. This allows the data carrier to operate in a credit mode. In a debit mode, the additional storage of use rules facilitates the regulation of access to content data stored on the carrier without the need for further exchange of payment/use data with an external system to validate the use.

[0025] By combining digital rights management with content data storage using a single carrier, the stored content data becomes mobile and can be accessed anywhere ~~whilst~~while retaining control over the stored data for the data content provider or data copyright owner. Preferably, the data carrier also stores access control data, such as a user ID and a password, as the stored data may be valuable. The access control data may be combined with access control to the payment data, which is typically by means of a PIN (Personal Identification Number) to simplify access to valued content stored on the carrier.

[0026] In one embodiment the stored content data is encrypted and a unique password or PIN and/or biometric data is required for decryption. The data carrier may be arranged so that the content is erased after a predetermined number of incorrect access attempts. Additionally or alternatively, a permanently stored flag may be set and/or a hardware modification (such as a fusible link) may be made to prevent the data carrier from functioning for further data storage/retrieval. Preferably, however, access to any stored value/payment data is nevertheless retained.

[0027] Supplementary data may also be stored on the carrier in association with stored content data. This supplementary data may comprise customer reward management data and/or advertising data. The supplementary data may comprise a pointer to an external data source from which data is downloaded either to the data carrier or to a data access device or content player, so that advertising or other data can be displayed when reviewing or accessing the stored content.

[0028] Additional data security and/or a mechanism for rewarding operators at different levels in the data supply chain may be provided using a content synthesis function. The content synthesis function combines partial content information from two or more sources to provide content data items for storage and/or output. Thus, for example, a first percentage of a content data item could be provided by a content retailer-~~whilst~~, while a remaining percentage could be provided by an on-line data supplier. This would provide an incentive for a user to register with a content retailer or distributor as well as with an on-line ~~scheme~~ system owner and so could encourage the use of existing retailers and could provide a mechanism for paying commission to such retailers. The two portions of data combined to provide a content data item could comprise encryption data and a key but preferably comprise separate parts of a complete data item, for example, least significant bits and most significant bits or high frequencies and low frequencies (for audio). This arrangement also facilitates customer reward and loyalty management.

[0029] In one embodiment the data carrier further comprises memory for storing data for accessing a mobile communications network, for example to receive content data over the network. For such an embodiment, the data carrier may replace a SIM (Subscriber Identity Module) card in a mobile communications device, thus providing a single card for both network access and valued content retrieval and storage. Additionally or alternatively the card may also store the web address of a data supplier from whom data may be downloaded onto the carrier.

[0030] The data memory for storing content data may be optic, magnetic or semiconductor memory, but preferably comprises Flash memory. Preferably, the data memory has a large capacity for storing large data files such as compressed video data. Preferably, the data memory is partitioned for lock access, that is, for read and/or write access to blocks of, for

example, 1K, 4K, 16K or 64K databytes for faster data access, particularly where the stored content data will normally be accessed serially, as is normally the case with audio and video data. Preferably the card is configured as an IC card or smart card and has a credit card-type format, although other formats such as the "memory stick" format may also be used. This provides a small and convenient portable format and facilitates removable interfacing with a variety of devices.

[0031] The invention also provides a related method of controlling access to data on a data carrier, the data carrier comprising non-volatile data memory and non-volatile parameter memory storing use status data and use rules, the method comprising receiving a data access request; reading the use status data and use rules from memory; and evaluating the use status data using the use rules to determine whether access to the stored data is permitted.

[0032] According to another aspect of the invention, there is provided a computer system for providing data to a data requester, the system comprising a communication interface; a data access data store for storing records of data items available from the system, each record comprising a data item description and a pointer to a data provider for the data item; a program store storing code implementable by a processor; a processor coupled to the communications interface, to the data access data store, and to the program store for implementing the stored code, the code comprising code to receive a request for a data item from the requester; code to receive from the communications interface payment data comprising data relating to payment for the requested data item; code responsive to the request and to the received payment data, to read data for the requested data item from a content provider; and code to transmit the read data to the requester over the communications interface.

[0033] The computer system is operated by a data supplier or data supply "scheme" "system owner" for providing content data to the data carrier described above. The payment data received may either be data relating to an actual payment made to the data supplier, or it may be a record of a payment made to an e-payment system relating either to a payment to the data supplier, or to a payment to a third party. The data from the content provider, preferably without permanent (local) storage of the forwarded data, improves data security as the content provider retains control over a content data item, and the data supplier, a copy of a data item, is unable to supply data for the item without the content provider's assistance. The

computer system may provide temporary storage for a requested data item, for example, using a disk cache, but preferably the computer system does not store a complete data item, even temporarily.

[0034] Preferably, the computer system includes payment distribution information so that when payment is made for a data item, the payment can be distributed for reimbursing royalties and making other payments. Typically a large fraction of the payment for a data item will be transferred to a copyright owner or "content provider" for the item, while smaller payments will go to the artist and/or publisher and/or retailer/distributor. Payment may be made directly by the computer system to the computer systems of other relevant parties using, for example, a signature-transporting type payment system. Alternatively, the computer system can issue appropriate instructions to a third party payment system for making the transfers. The computer system allows automatic distribution of payments either before, during or after content data download, or after content data access by a user. Instructions for distributing the payments may be issued substantially simultaneously, thereby avoiding long delays in the payment of some parties; for example, it can presently take a year or more for an artist generating content to be paid by conventional methods.

[0035] Preferably, the computer system also stores content data item access rule data, for downloading in association with a content data item. The rule data may be stored by a content provider but is preferably held by the computer system, and links a content identifier with an access rule, typically based upon a required payment value, as outlined above in the context of the data carrier. Normally, each content data item will have an associated access rule, but a single rule may apply to a large number of data items. The computer system also, preferably, stores requester reward data for customer reward/loyalty management. This data may again comprise one or more rules linking a payment value and/or content data item type to a specified reward, such as a number of air miles or retailer value points. The computer system preferably also keeps a record of an identified user's or data's carriers content item downloads and payments for market research purposes.

[0036] The computer system, in one embodiment, also stores access control data, such as an access request identity and password which can be employed, for example, to create an extranet of system users, which again can be linked to stored access record data for marketing

purposes. When further linked to content item type data, such an arrangement can be used to construct a club of users of content data items of a particular type, for example, country and western or rock and roll music. As described in connection with the portable data carrier, the computer system may also comprise content synthesis code for additional data security and for more secure management of payment distributions.

[0037] The invention also provides a related method of providing data to a data requester comprising receiving a request for a data item from the requester; receiving payment data from the requester relating to payment for the requested data; reading the requested data from a content provider responsive to the received payment data; and transmitting the read data to the requester.

[0038] According to a further aspect of the present invention, there is provided a data access terminal for retrieving data from a data supplier and providing the retrieved data to a data carrier, the terminal comprising a first interface for communicating with the data supplier; a data carrier interface for interfacing with the data carrier; a program store storing code implementable by a processor; and a processor, coupled to the first interface, the data carrier interface and to the program store for implementing the stored code, the code comprising: code to read payment data from the data carrier and to forward the payment data to a payment validation system; code to receive payment validation data from the payment validation system; code responsive to the payment validation data to retrieve data from the data supplier and to write the retrieved data into the data carrier.

[0039] This terminal can be used for retrieving data from the above-described computer system and for downloading the retrieved data to the above-described portable data carrier. As with the data supply computer system, it is preferable that there is no (local) storage of content item data forwarded from the data supplier to the data carrier. The data access terminal is not restricted to use with the above-described status supplier and could, for example, retrieve data for downloading to the data carrier from a local data source, such as a CD (Compact Disc) or DVD (Digital Versatile Disc), or from a third party such as a cable TV company.

[0040] The terminal reads payment data from the data carrier and transmits this to a payment validation system for validating the data and ~~authorising~~ authorizing the payment. This may

be part of the data supplier's computer system or it may be a separate system such as an e-payment system. Thus, the terminal operates with a data carrier storing payment (validation) data and, in some embodiments, additional payment validation code for validating payment to the payment validation system. Again, the terminal is preferably configured to provide a data item use rule to the carrier in conjunction with a data item. As before, the data item use rule will normally be dependent upon payment value information embodied in the payment data read from the data carrier. The terminal is preferably also configured for user input of access control data. This access control data may be forwarded to the data carrier for access permission verification and/or it may be passed to the data supplier computer system for a similar purpose. The terminal may be configured to warn a user of content access or data carrier function inhibition after a predetermined number of access requests have been refused. The terminal may also incorporate content synthesis code as described above.

[0041] The terminal may comprise code to output supplementary data when downloading data to the data carrier. Identity data on the data carrier can be used to retrieve the supplementary data, or a pointer to the supplementary data, from the data supplier computer system, or the supplementary data or a pointer thereto can be retrieved directly from the data carrier. Preferably, however, identification data on the card is used to retrieve ~~echaracterising~~ characterizing data such as card user preference data from the data supplier computer system, and this ~~echaracterising~~ characterizing data is then used by the terminal to retrieve and output supplementary data to a terminal user. When the terminal is associated with a contact distributor or retailer, the supplementary data may be retrieved over a network associated with the retailer/distributor such as a local area network (LAN), wide area network (WAN) or extranet.

[0042] The invention also provides a method of providing data from a data supplier to a data carrier, the method comprising reading payment data from the data carrier; forwarding the payment data to a payment validation system; retrieving data from the data supplier; and writing the retrieved data into the data carrier.

[0043] The payment validation system may be part of the data supplier's computer systems or it may be a separate e-payment system. In one embodiment the method further comprises receiving payment validation data from the payment validation system; and transmitting at least a portion of the payment validation data to the data supplier. Alternatively the payment

validation system may comprise a payment processor at the data supplier or at a destination retrieved from the data supplier. The payment processor may also provide payment distribution data for distributing a payment represented by the payment data.

[0044] In a further aspect, the invention provides a data access device for retrieving stored data from a data carrier, the device comprising a user interface; a data carrier interface; a program store storing code implementable by a processor; and a processor coupled to the user interface, to the data carrier interface and to the program store for implementing the stored code, the code comprising code to retrieve use status data indicating a use status of data stored on the carrier, and use rules data indicating permissible use of data stored on the carrier; code to evaluate the use status data using the use rules data to determine whether access is permitted to the stored data; and code to access the stored data when access is permitted.

[0045] The data access device uses the use status data and use rules to determine what access is permitted to data stored on the data carrier. As described above, the use rules will normally be dependent upon payments made for data stored on the data carrier, but may also comprise access control employing a user identification and password. Since a single data carrier may have more than one user, the use status and use rules may be selected dependent upon a user identity. The data access device may also be configured to present supplementary data when presenting the content data, retrieved as described above, from the card, from a remote computer system or from some other source such as a cable TV network or off-air.

[0046] The invention also provides a related method of controlling access to data from a data carrier, comprising retrieving use status data from the data carrier indicating past use of the stored data; retrieving use rules from the data carrier; evaluating the use status data using the use rules to determine whether access to data stored on the carrier is permitted; and permitting access to the data on the data carrier dependent on the result of said evaluating.

[0047] According to a further aspect of the invention there is provided a data access system comprising a data supply computer system for forwarding data from a data provider to a data access terminal; an electronic payment system for confirming an electronic payment; a data access terminal for communicating with the data supply system to write data from the data supply system onto a data carrier; and a data carrier for storing data from the data supply

system and payment data; wherein data is forwarded from the data provider to the data carrier on validation of payment data provided from the data carrier to the electronic payment system.

[0048] In a further aspect of the invention, there is provided a portable data carrier comprising an interface for sending and receiving data from and to the carrier; non-volatile data memory, coupled to the interface, for storing data on the carrier; and a digital rights management processor for controlling access to the stored data.

[0049] In a further aspect of the invention, there is provided a portable data carrier comprising an interface for sending and receiving data from and to the carrier; non-volatile data memory, coupled to the interface, for storing data on the carrier; and an access control processor; wherein the data memory is partitioned as data blocks and the access control processor controls external access to the data blocks.

[0050] In a further aspect of the invention, there is provided a computer system for providing data to a data requester, the system comprising a communication interface; a data access data store for storing records of data items available from the system, each record comprising a data item description and a resource locator; a data provider for the data item; a program store storing code implementable by a processor; a processor coupled to the communications interface, to the data access data store, and to the program store for implementing the stored code, the code comprising code to receive a request for a data item from the requester to receive from the communications interface payment data comprising data relating to payment for the requested data item; code, responsive to the request and to the received payment data, to output the item data to the requester over the communication interface; wherein said data access data store further comprises payment distribution information indicating to whom payments should be made for a data item; and further comprising code to output payment data for a data item for making payments for the item when the item is supplied to a said-requester.

[0051] In a further aspect of the invention, there is provided a computer system for providing data to a data requester, the system comprising a communication interface; a data access data store for storing records of data items available from the system, each record comprising a data item description and a printer location data identifying an electronic address for a provider for the data item; a program store storing code implementable by a processor; a

processor coupled to the communications interface, to the data access data store, and to the program store for implementing the stored code, the code comprising code to receive a request for a data item from the requester to receive from the communications interface payment data comprising data relating to payment for the requested data item; code responsive to the request and to the received payment data to output the item data to the requester over the communication interface; wherein ~~said the~~ data access data store further comprises data item access rule data for output to the requester with a ~~said~~ data item; and further comprising code to select access rule data for output with a data item in response to ~~said the~~ payment data.

[0052] In a yet further aspect of the invention, there is provided a method of providing data to a data requester comprising receiving a request for a data item from the requester; receiving payment data from the requester relating to payment for the requested data; transmitting the requested data to the requester; reading payment distribution information from a data store; and outputting payment data to a payment system for distributing the payment for the requested data.

[0053] In a still further aspect of the invention, there is provided a method of providing data to a data requester comprising receiving a request for a data item from the requester; receiving payment data from the requester relating to payment for the requested data; transmitting the requested data to the requester; and transmitting data access rule data to the requester with the read data.

[0054] These and other aspects of the invention will now be further described, by way of example, only, with reference to the accompanying figures ~~in which:-~~

Brief Description of the Drawings

[0055] Figure 1 shows a data access device a) from the top; b) from the front; and c) from the side;

[0056] Figure 2 shows, conceptually, a portable data carrier;

[0057] Figures 3a and b show exemplary data access terminals;

[0058] Figures 4a and b show, respectively, a logical signal path between elements of a conceptual data access system; and a physical representation of a conceptual data access system;

[0059] Figure 5 shows a content provision system;

[0060] Figure 6 shows a data supply computer system;

[0061] Figure 7 shows a variety of data access terminals;

[0062] Figure 8 shows a schematic diagram of components of a data access terminal;

[0063] Figure 9 shows a schematic diagram of components of a data carrier;

[0064] Figure 10 shows a schematic diagram of components of a data access device;

[0065] Figures 11a and 11b show ~~a~~ are flow diagrams of a data carrier registration process;

[0066] Figures 12a-c and 12d-e show, respectively, a flow diagram of data access using a data access terminal; and a flow diagram of data supply using a data supply computer system; and

[0067] Figure 13 shows a flow diagram of data retrieval using a data access device.

Description of the Preferred Embodiments

[0068] Referring to Figure 1, this shows a data access device for playing MP3 audio (10) with operator controls (12) and LCD display (14). The outline of a smart card data storage device is shown at (16). The operator controls allow a user to select and play tracks, ~~whilst~~ while track information and still or video images are provided on display (14). A slot (18) is provided in the front of the device to receive a smart card-type data storage means. This smart card occupies space (20) and interfaces with resilient contacts (24); it is held in the data retrieval device against the contacts, by resilient housing element (22).

[0069] Referring now to Figure 2, this shows a portable data carrier (30) suitable for use with the device of Figure 1. The data storage means is based on a standard smart card; it is plastic, about the size of a standard credit card, and has some flexibility. On the card (30) are

two sets of contacts, contacts (32) for interfacing with the payment validation means and contacts (34) for interfacing with the memory for storing downloaded data (although in other embodiments, a single set of contacts may be used for both). The surface of the card can be embellished with suitable graphics.

[0070] In one embodiment the smart card retains all its useable functionality as specified for standard Electronics Point of Sale Systems (EPOSS) and, if desired, the memory for storing the downloaded data can be electrically separate from this. However, it may be preferable to provide interaction between the standard smart card device and the data memory in order to accomplish the access control/decryption functions described above.

[0071] Referring now to Figure 3, an example of a data access terminal is shown at (40). This has a screen (42) and a slot (44) to receive the data carrier (30). Alternatively the data carrier may interface to the terminal via the data access device (10) and an interface (46) to the terminal (40). In Figure 3b a dedicated terminal (50) has a slot (52) to receive the data carrier, a display (54) and controls (56). Coins can be inserted into the terminal at (58) and notes at (60) to charge the data carrier with cash.

[0072] Referring now to Figure 4a, this illustrates conceptually the logical connections and data flow between data processing systems involved in payment validation, and data download to the carrier (30). A user connects the data carrier (30) to terminal (40) and logs on to a data web page of data supply service provider (60). Either terminal (40) or service provider (60) then communicates via data paths (62) with a payment validation authority (70) to check and ~~authorize~~ authorize the user's or payer's payment. In the case of electronic cash the terminal (40) may immediately validate the payment information, updating the service provider and/or payment validation authority (70) at a later stage. The logical connection (64) between the terminal and the service provider is preferably made over the internet.

[0073] The service provider may provide a direct portal to data providers (80) or may collect information from data suppliers (80) and provide a "front end" to present data from the suppliers to the terminal user. Alternatively, data supply service provider (60) may regulate direct access between terminal (40) and data providers (80), as shown by links (66), by communicating with the terminal and the data providers to provide communication regulation

information to, for example, instruct data suppliers about what information the user of terminal (40) should have access to.

[0074] In a preferred embodiment, service provider (60) pays royalties at an agreed rate - for example, 10 pence per track or 10 pence per minute - to a computer system owned by a company or entity in the recording industry, such as a content provider or copyright owner, a content publisher or a content creator, and the user of terminal (40) effectively pays the service provider. Billing can also be regulated by bandwidth and/or data download time.

[0075] Preferably the service provider (60) monitors the user's access to the system and either stores or forwards to data providers (80), or downloads to the data carrier (30), usage information. In a preferred embodiment the service provider sends information via terminal (40) to data carrier (30) which can be used to determine incentives to be provided to users of the system.

[0076] Figure 4b shows a conceptual physical configuration of the system of Figure 4a in which a plurality of terminals (40), a plurality of service providers (60) and a plurality of data providers (80) all interact via the internet. The physical embodiment of the system is not critical and a skilled person will understand that the terminals, data processing systems and the like can all take a variety of forms.

[0077] Referring now to Figure 5, this shows a conceptual illustration of a content provision system 100. Content creators 104a, b generate or receive content data from artist terminals 102a-d and store content data in databases 106a, b. The content data stored in databases 106a, b may comprise audio data, such as music, video data, such as films or TV programs, text, such as literary works, software, such as games software, or other data. Content creators 104a, b are coupled to communications network 101 for communicating created content data over the network. Also coupled to communications network 101 are content publishers 110a and 110b, each of which is coupled to an associated stored content database, 112a and 112b respectively. The content publishers make their stored content available for controlled access using communications network 101. In some instances, for example where the content data comprises computer games, the functions of content creator and content publisher may be provided by a single entity. Also although conceptually illustrated as blocks in Figure 5, the

content creator and content publisher typically each comprise a client server computer network.

[0078] The communications network 101 is typically a private communications network, such as an extranet, with security controlled access to entities connected to the network. Physically the network may comprise an internet protocol network or it may comprise, or consist of, dedicated point-to-point links. Thus, for example, a content creator 104 may be directly linked to a content publisher 110 and/or to other entities shown in Figure 5 such as a content provider or content distributor.

[0079] The content provision system includes a plurality of content providers 108a-e, each coupled to the communications network 101. In the illustrated system, the content providers own copyright in stored content data accessible over communications network 101 and may, in practice, also perform a content publication function. Five content providers own the copyright in over 80% of all world-wide music sales. The content providers are coupled to stored content databases 106 and 112 via communications network 101, for supplying stored content data.

[0080] A gateway server 114 is also coupled to communications network 101 to link the communications network to other networks such as the internet and/or mobile communications networks. Gateway server 114 provides security and access control functions and firewalls. A second gateway, content distributor WAN gateway ~~116-116~~, is also shown attached to communications network 101. This provides similar security and firewall functions and coupled communications network 101 to distributor WAN (wide area network) 117. Gateway 116 has logical access to one or more of a content creator, content publisher and content provider for accessing stored content data. Content distributor gateway 116 may be owned by a chain of record stores and provide content access terminals 118, coupled to WAN 117, in separate retail outlets. Content access terminals 118 have access, via gateway 116, to stored content accessible over communications network 101.

[0081] Referring now to Figure 6, this shows a data supply computer system 120. In this embodiment, three content access terminals 118a-c, e-payment systems 121a, b, and content access web server 124 are all coupled to internet 142. Data supply system 120 is coupled to the content provision system 100 illustrated in Figure 5. Where ~~Communications~~

communications network 101 of Figure 5 is an extranet, this extranet physically operates over internet 142; where communications network 101 does not partly operate via internet 142, a connection to internet 142 is established via gateway server 114 as shown in Figure 5. In this way content access terminals 118a-c are provided with controlled access to the stored content data of content provision system 100.

[0082] E-payment systems 121a and 121b are coupled to banks 122a, b and c, d respectively. These provide an e-payment system according to, for example, MONDEX, Proton, and/or Visa cash compliant standards. Preferably at least one of e-payment systems 121a, b operates a so-called "open purse" system in which the value is stored as a publicly verifiable digital signature issued by the e-payment system. In such a signature-transporting arrangement, payment data may be validated using public keys and thus payment authentication need not be performed by the e-payment system but may instead be performed by, for example, a data access terminal or data supply system computer, using payment management code. The authenticated signatures; which in effect perform a similar role to ~~cheques~~ checks, are submitted to the relevant e-payment system after authentication for verification and reimbursement or transfer of monetary value. With such a system payments may be made anonymously and thus payer identification is not essential. Data carriers, such as data cards, may be issued with stored value or without value, in which latter case value (that is, a publicly verifiable digital signature) may be written onto the card during an on-line transaction.

[0083] In alternative embodiments, a data carrier such as the smart flash-Flash card described below may be used to create value bearing digital signatures as is well-known to those familiar with e-money.

[0084] Content access web server 124 is also coupled to internet 142 for providing content access terminals 118a-c with access to content data. Content access web server 124 is typically owned by a content data supply "~~scheme~~" system owner" who acts as an intermediary between a content access terminal user and a content provider, forwarding content data provided (directly or indirectly) by a content provider to a content access terminal and ~~thence~~ then to a stored content data carrier. Web server 124 is coupled to web server code storage 126 storing Java code for generating web pages for interpretation by web browsers on content access terminals 118a-c. The web pages provide the content download,

value add, CRM (customer reward management) value cheque-check/spend and website link functions described below.

[0085] Web server 124 is coupled to payment processor 128, Digital Rights Management (DRM) processor 130, access control processor 132, and content distribution processor 134. Payment processor 128 includes payment management code storage 128a and is coupled to payment record data store 136. Access control processor 132 includes access control code storage 132a and is coupled to access control data store 138. DRM processor 130 includes DRM code storage 130a and is coupled to content access and DRM data store 140. Content distribution processor 134 includes CRM (customer reward management) and payment distribution management code storage 134a and is also coupled to content access and DRM data store 140. As shown in Figure 6, processors 128-134 are all in communication with one another.

[0086] Processors 128, 130, 132 and 134 may comprise separate application programs or a single computer program and may operate on a single physical computer, on which web server 124 may also be provided, or may operate on separate computers. Likewise data stores 136, 138 and 140 may comprise a single physical data store or may be distributed over a plurality of physical devices and may even be at physically remote locations from processors 128-134 and coupled to these processors via internet 142.

[0087] Web server 124 communicates with processors 128-134 by means of a CGI (common gateway interface) script and the code associated with processors 128-134 may be written in any conventional computer language such as C, C++, or Perl. However, in other embodiments one or more of the processors may be coupled to web server 124 via internet 142 and owned and operated by a separate entity, such as a financial institution. In this case conventional secure web-based communications may be operated between web server 124 and the relevant processor. In particular, payment processor 128 may be operated by one of the e-payment system providers 128a, b.

[0088] Payment management code 128a issues and authenticates payment data and stores an audit record in payment record data store 136. Access control code 132a stores identification data (of a user or card) together with registration data provided by a user when registering with the ~~se~~ home-system owner. This data comprises a user password for accessing stored

content and/or payment data; user ~~characterising~~ characterizing data, for example ~~characterising~~ characterizing user preferences, for marketing purposes; data indicating an e-payment system to use; and in some embodiments, further general user related data such as card level data for identifying the provision of "gold" level services to selected users. A copy of the password is stored with the content data on the portable data carrier, as described further below. Alternatively, one or both of the access control data store and portable data carrier may simply store data for verifying a user-entered password.

[0089] Content access and DRM data store 140 stores data related to content access and content use, but does not itself store content data items; these are instead provided via content provision system 100 described above. Data store 140 stores a plurality of records each comprising a data item identifier, a data item description, a data item type or genre, and location data comprising one or more pointers to a location or locations from where the data item can be downloaded. Associated with a data item is also a table of use rule data comprising a list of values (i.e. content data item prices) and corresponding levels of permitted usage. Thus a value of £1 might permit ten plays of a music track, ~~whilst-while~~ the value of £10 might permit an unlimited number of plays of the track and copying of the track for personal use.

[0090] Also associated with a data item is a table of payment distribution data comprising a list of recipients and corresponding fractions of the data item value each is to receive. Typically, the main recipient will be the copyright owner of the data item and other recipients will be selected from the content creator, the artist or artists, the ~~scheme-system~~ owner, the content publisher, and the retailer/distributor. The payment distribution proportions may be dependent upon the payment value, in which case a plurality of sets of payment distribution figures may be associated with each data item, each set of distribution figures corresponding to a payment value range. The payment data and distribution data is here termed DRM (Digital Rights Management) data.

[0091] Further associated with a data item is a table of CRM (Customer Reward Management) data, linked to the user rule data, comprising CRM rules to specify, for one or more data item use levels, a quantity of reward points and one or more recipients for the reward points (the recipients may include the card user and the retailer/distributor).

[0092] The CRM and payment distribution code 134a operates with content access and DRM data store 140 to inform a system user of the description and value of a data item, to access and download a data item from the content provider system to a content access terminal, to provide content use rules with the data item, and to provide instructions either to payment processor 128 or to ~~the~~ payment system 121 to distribute payments for the data item to the recipients identified by the data store 140 and to distribute CRM reward points.

[0093] The access control data store 138 holds a secure key, such as a secret "public" key in a public key cryptography system, for the ~~scheme-system~~ owner to authenticate its identity to a content provider. This data is held securely with other sensitive data in the access control data store 138. As is described in more detail below, when data supply system 120 receives a request for a content data item from a content access terminal 118, it looks up a location from which the data item is available using content access and DRM data store 140 and then determines the identity of the corresponding content provider. This identity is either stored in content access and DRM data store 140 or, as there are relatively few content providers, it may be hard written in DRM code 130a. DRM code 130 then requests access control processor 132 to provide the secure ~~scheme-system~~ owner identifier from access control data store 138 to the relevant content provider and sets up a trusted connection between the content provider and content access web server 124 for downloading the data item to a content access terminal 118 and ~~thence-then~~ to a portable data carrier.

[0094] Referring now to Figure 7, this shows a variety of content access terminals for accessing data supply computer system 120 over internet 142. The terminals are provided with an interface to a portable data carrier or "smart Flash card" (SFC) as generally described with reference to Figure 2 and as described in more detail below. In most embodiments of the terminal the SFC interface allows the smart Flash card data carrier to be inserted into and removed from the terminal, but in some embodiments the data carrier may be integral with the terminal.

[0095] Referring now to the specific embodiments illustrated in Figure 7, a simple content access terminal may comprise a home personal computer 144 with SFC interface 144a. In another embodiment, a mobile communications device 152 is provided with a smart Flash card interface 152a and is coupled to internet 142 via radio tower 150, mobile communications system 148 and mobile communications internet gateway 146.

[0096] In another embodiment, a smart Flash card interface is provided to a so-called "set top box" (STB) 154. The set top box is, in effect, a receiver for television programmes received on video input 154b, which may comprise a satellite TV signal, a cable TV signal or an off-air TV signal. The video signal is provided from the set top box to television 156 or to some other home entertainment device such as a personal computer (not shown). In another embodiment, content access terminals 166 and 168 each with respective SFC interfaces 166a and 168a are coupled to a retailer local area network (LAN) 160 connected to internet 142 via retailer LAN server 158. DVD player 164 is also coupled to LAN 160. In a further embodiment a smart Flash card interface 170a is provided for a CD/DVD player 170.

[0097] In these latter three embodiments, content data for storage on the smart Flash card may be retrieved from broadcast video and/or a CD or DVD. In this case, the computer data supply system 120 illustrated in Figure 6 may be used to provide use rule data for the content data stored on the smart Flash card, and to pay for data downloaded onto the card; the content data may be captured before or after the data supply system 120 is accessed to enable use of the stored data, but in a preferred embodiment content data written to the card from a supplier other than the content data supply computer system is not accessible to a user until corresponding use rule data has been downloaded from computer system 120, which will normally be after receiving payment for the downloaded data.

[0098] Referring now to Figure 8, this shows a schematic diagram of one embodiment of a data access terminal 170. The terminal comprises a general purpose computer including an audio/visual interface 184, a keyboard 186 and a pointing device 188 for providing an interface to the user. The terminal has an internet interface 176, for example a modem, and optionally a LAN/WAN interface 174 for connecting the terminal to a retailer or distributor LAN or WAN. The terminal also has an optional video input 178 for receiving broadcast video data and a media input device 180, such as a CD or DVD drive. Further communications I/O ports 182 may also be provided. A portable data carrier or smart Flash card interface 190 is provided for interfacing to a smart Flash card. Optionally, a cash input and verification system 192, such as is conventionally used in an automatic teller machine (ATM), may also be incorporated within the content access terminal. The terminal has working memory 194 such as RAM and program memory 196 which can comprise any conventional storage device such as RAM, ROM or a disk drive. Program code in program

memory 196 may also be stored on removable disk 198. A processor 200 loads and implements program code stored in program memory 196. All the components of the terminal are linked by a data and communications bus 172.

[0099] More specifically, processor 200 loads and implements cash payment management code 200a for managing cash input data from cash input and verification system 192, for adding value to a smart Flash card. Processor 200 also implements a web browser 200b for accessing ~~scheme system~~ owner web pages and data exchange interface 200c for exchanging data between a smart Flash card interface to the terminal and data supply system 120.

[0100] Processor 200 also implements off-line contents retrieval code 200d for retrieving data for storage on a smart Flash card from media input device 180 and/or video input 178 and/or LAN/WAN interface 174. The processor implements a content sampler 200e for outputting small extracts of content data items to a user via audio/visual interface 184. Such data item samples may be stored with the content description data in content access data store 140. The processor also implements a smart Flash card interface driver 200f, user interface code 200g and additional communication drivers 200h for driving LAN/WAN interface 174 and/or comms I/O ports 182.

[0101] Referring now to Figure 9, this shows a schematic diagram of components of a portable data carrier 202, in the embodiment shown a so-called "smart Flash card". In this context, "smart Flash card" refers to an IC card similar in size to a plastic payment card incorporating a processor and Flash data memory, preferably of large capacity. For further details on smart cards, reference may be made to the ISO (International Standards ~~Organisation~~ Organization) series of standards, including ISO 7810, ISO 7811, ISO 7812, ISO 7813, ISO 7816, ISO 9992 and ISO 10102, which are hereby incorporated by reference.

[0102] Referring in more detail to Figure 9, a data and communications bus 204 links components of the card which include a processor 210, working memory 212, timing and control logic 208 and an external interface which may have contacts (ISO 7816) or be contactless (ISO 10536) for providing external access to a bus 204 for reading data from and writing data to the card 202. Also coupled to bus 204 are permanent program memory 216, non-volatile data memory 218 and non-volatile (Flash) content data memory 214. Non-volatile data memory 218 may comprise EEPROM and permanent program memory 216 may

comprise ROM, for example, mask-programmed ROM. All the components of Figure 9 are mounted on a single substrate, in a preferred embodiment bearing contacts for external interface 206.

[0103] Processor 200 loads and implements program code from permanent program memory 216. This code comprises operating system code for providing the card with a basic operating system for at least external communications; payment management code for supplying payment data from non-volatile data memory 218 to pay for downloaded content; DRM (Digital Rights Management) and security code, including code to implement content data use rules and code for password controlled access to data and program functions; CRM code for implementing CRM-related rules; and content synthesis code for combining stored content data with additional data provided via external interface 206 for synthesizing complete content item data.

[0104] Non-volatile data memory 218 stores data including card identity data, access control data, including password data for validating a user password, access record data for storing a record of access attempts and their outcomes, and content supply data such as ~~scheme-system~~ owner website addresses and retailer/distributor website addresses.

[0105] Data memory 218 further stores card value data comprising E-money such as publicly verifiable digital signatures, and payment data for storing a payment audit trail including payment amounts and data on to whom payments have been made. The memory 218 also stores RFM (Recency Frequency Monetary) data to provide a record of transactions for market research and customer reward purposes, and CRM data storing customer reward points. Data memory 218 also stores an index of content data items stored in Flash memory 214 and associated content use rules, as well as DRM and royalty data for maintaining an audit trail of use history for rights management tracking. Optionally, data memory 218 may also store supply chain data specifying a supply chain route through which data has been obtained from a content provider, which may be used for rewarding supply chain intermediaries, for example on a commission or reward points basis.

[0106] Content data memory 214 preferably comprises at least 100 MB of data storage, partitioned as data blocks of a size selected to match the stored content type. For storing

video data, Flash memory 214 preferably comprises > 1 GB data storage and the data blocks into which the data memory is partitioned are larger.

[0107] Referring now to Figure 10, this shows a schematic diagram of a data access device 220, such as a portable audio/video player. The data access device 220 comprises a conventional dedicated computer system including a processor 238, permanent program memory 236, such as ROM, working memory 234, such as RAM, and timing and control logic 226 all coupled by a data and communications bus 222. Also coupled to the bus are an audio interface 228, a display 230 and user controls 232, for providing a user interface. A smart Flash card interface 224 is coupled to bus 222 for interfacing with a smart Flash card for retrieving and playing stored content data.

[0108] Permanent program memory 236 stores program code for implementation by processor 238; this code may also be provided on a data carrier such as a ROM chip or disk 240. Processor 238 implements an SFC interface 238a, a user interface 238b, a content player 238d for retrieving stored content data from a smart Flash card interfaced to the device and for outputting audio and/or video data derived from the retrieved content data (which may comprise compressed audio and/or video data) to a user of the device.

[0109] Processor 238 also implements use control 238c for controlling access to and use of contents stored on the smart Flash card by the content access device user. Use control routine 238c and/or DRM and security code in permanent memory 216 on the smart Flash card may also implement digital watermarking and other Secure Digital Music Initiative (SDMI) content protection code as specified in the SDMI portable device specification, part one, version 1.0 (see www.sdmi.org) which is hereby incorporated by reference.

[0110] Figures 11a and 11b show a flow diagram of a process for registering a data carrier or smart Flash card with a data supplier or ~~scheme~~ system owner operating a data supply system as illustrated in Figure 6. A smart Flash card may be issued entirely blank, that is, with no prestored content or value, with prestored value but no prestored content, with prestored content but not prestored value (the content being provided free) or with both prestored value and prestored content. Thus, for example, a user may purchase a card with stored value but no stored content over the counter at a retailer. The process of Figures 11a and 11b illustrates the registration of a card with neither prestored content nor prestored value. As illustrated the

registration process records user registration data in the access control data store 138 of Figure 6 and writes value data onto the blank card.

10111 At step S10 a smart Flash card is inserted into a content access terminal smart Flash card interface. The ~~scheme-system~~ owner web page is then loaded onto the content access terminal and displayed to the user (step S11). User registration data is then entered into the content access terminal (step S12) and transmitted to the ~~scheme-system~~ owner (S13), ~~the~~. The user registration data may include a user identity, a preferred e-payment system to use and, optionally, a content access PIN or password, and a service level (for example bronze, silver or gold). The optional password may be a password required by the e-payment system for validation of a payment by the user with the card or it may be a password to protect ~~unauthorised-unauthorized~~ access to content on a smart Flash card to protect stored data in the event, for example, of the card being stolen. A single password may serve both these functions. The content access terminal web browser is configured so that all sensitive data passing between the terminal and the ~~scheme-system~~ owner is securely transmitted, for example by using a conventional encryption system such as PKI (Public Key Infrastructure).

10112 At step S14 a payment request is received from the ~~scheme-system~~ owner at the content access terminal and displayed to the user. At step S15 the user enters payment data into the content access terminal and this payment data is transmitted to the ~~scheme-system~~ owner, for adding value to the card. This may, for example, be a credit card transaction as is conventionally used for purchase over the internet. Card value data and a card value access code is then received by the content access terminal from the ~~scheme-system~~ owner at step S16. The card value corresponds to the payment made by the user and the value access code may be a password entered by the user at step S12 or may comprise a password for PIN created by payment processor 128 or e-payment system 121 as illustrated in Figure 6. In a preferred embodiment, the user pays the ~~scheme-system~~ owner and the ~~scheme-system~~ owner then directly provides digital signature data representing value to the content access terminal for writing onto the smart Flash card.

10113 At step S17, card registration data is received from the ~~scheme-system~~ owner by the content access terminal and written onto the smart Flash card. This card registration data comprises user identity data, access control data, payment system specifying data, ~~scheme system~~ owner access data, such as a ~~scheme-system~~ owner web page address and other dial-up

information. At this stage other data may be entered by the user and written onto the card, including, for example, user preference data, retail outlet and CRM data (alternatively user preference data may be captured at step S12). At step S18 the card value data and card value access code received at step S16 is written onto the card and output to the user visually and, optionally, as a printed record. The card is then available for use, at step S19.

[0114] Figure 11b shows the corresponding registration steps performed by the ~~scheme~~ system owner's data supply system 120. At step S20, a request for a smart card registration web page is received from a content access device and, at step S21, transmitted to the device. User registration data is then received, at step S22, from the content access terminal and stored in content access control data store 138. The ~~scheme~~ system owner's computer system then transmits, at step S23, a payment request to the content access terminal and receives, at step S24, payment data in reply, this payment is then authenticated, at step S25, with an ~~Ee~~ payment system such as payment system 121 a or b illustrated in Figure 6, and after verification the payment processor 128 of the computer system transmits, at step S26, value data and a value access code to the content access terminal, for writing onto the smart Flash card. The payment processor then updates the payment record data store 136 with data relating to the transaction (step S27) and, at step S28, retrieves card registration data previously written into the access control data store and transmits this registration data to the content access terminal. At step S29 the transaction is then complete.

[0115] Referring now to Figures 12a to c, these illustrate a flow chart for downloading data to a smart Flash card using a data access terminal. At step S30 the smart Flash card is inserted into the content access terminal and the user then enters, at step S31, their password for gaining access to the functionality of the smart Flash card. At step S32, the content access terminal transmits the password to the smart card for verification and the terminal checks, at step S33, whether access is permitted. If access is not permitted a warning is displayed by the terminal, at step S34, and an access denied count is implemented. A threshold count is then read from the card together with a count of the total number of times access to the card has been denied (step S35). At step S36 the terminal checks whether the total number of denied accesses is within three of the card threshold, and if it is not, returns to step S31 ~~whilst~~ while if it is, it proceeds to step S37 where the terminal displays a warning that a further denied access is likely to result in erasure of content stored on the card. At step S38 the

terminal then checks whether ~~it's~~ its count of denied accesses is greater than its threshold value, returning to step S31 if not, and displaying an access refused message at step S39 if the total number of permitted accesses has been exceeded. The system then waits at step S39 for removal of the smart Flash card from the content access terminal.

[0116] If access is permitted at step S33, the terminal loads outline CRM data from the card (step S40) and loads retail data, such as targeted advertising, from the retailer LAN/WAN (step S41). At step S42, the terminal then displays a menu of options, retail data such as advertising or CRM-related data and outline CRM data, such as a total number of reward points earned, on the content access terminal. Many options include download content (from a ~~scheme-system~~ owner), add monetary value (to the card), check/spend CRM value stored on the card, follow website links, and exit. At step S43, the user inputs a menu option which, in the illustrated flow chart, is the download option. The system thus passes to step S44 and loads the ~~scheme-system~~ owner's content access web page onto the content access terminal and displays this to the user.

[0117] At step S45, the user enters a content search request, which is transmitted to the ~~scheme-system~~ owner content distributor processor 134. Content search results are received back from the content distribution processor, including a content identifier, a brief description, and content cost data for at least one payment option, and these results are displayed on the user on the content access terminal. The user then selects one or more content items at step S47 and the selection is transmitted to the content distribution processor 134 where further content cost data and purchase option data is retrieved from data store 140. At step S48, this content cost and purchase data (including use rule data) is received from the ~~scheme-system~~ owner and displayed to the terminal user. The user then selects, at step S49, a purchase option and confirms a purchase request or, alternatively, selects "exit" to return to the menu display of step S42. After one or more content items have been selected, together with a purchase option, hard value and CRM data is read from the smart Flash card at step S50, and at step S51 a check is made to determine whether the monetary and/or CRM (reward points) value stored on the smart Flash card is sufficient to purchase the selected purchase data items. If the card value is insufficient, a warning is displayed at step S52 and the system returns to the menu display at step S42. If the card value is sufficient, at step S53 the content access terminal transmits a payment request to the smart Flash card.

[0118] Payment for the data item or items requested may either be made directly to the scheme-system owner or may be made to an e-payment system such as e-payment systems 121a and 121b of Figure 6, with these systems then forwarding payment confirmation data to the scheme-system owner computer system. Alternatively, the content access terminal may transmit data to the card to set up a transaction directly with a content provider who, being the copyright owner, would normally receive the majority of the payment.

[0119] At step S54, payment data for making a payment to the scheme-system owner is received from the smart Flash card by the content access terminal and forwarded to an e-payment system such as E-payment system 121 in Figure 6. Payment record data, validating payment by the card to the scheme-system owner, is then received back from the e-payment system at step S55 by the content access terminal and forwarded to the card for updating payment data on the card. In alternative embodiments, payment data from the card may be provided directly to the scheme-system owner's data supply computer for authentication and, optionally, further validation with an e-payment system by the scheme-system owner's computer.

[0120] Distribution of the payment received by the scheme-system owner from the card is performed by the scheme-system owner's computer system, as described elsewhere. Such payment distribution will normally provide a small percentage of the total payment to a "owner" or operator of the content access terminal, such as a retailer, distributor, or in other embodiments, mobile communications network operator or cable TV network operator.

[0121] In the presently described embodiment, payment record data received in step S55 is transmitted to the scheme-system owner to confirm payment by the card and thus it is the content access terminal, in the described embodiment, which authenticates a payment before confirming that the payment has been made to the scheme-system owner.

[0122] In step S56, together with the payment record data, purchase request and card registration data is transmitted to the scheme-system owner to identify one or more content data items for purchase and to identify the purchaser. Then, at step S57, the content access terminal sets up a transaction between the scheme-system owner data supply computer and the smart Flash card for download of the identified content items requested from the data

supplier to the smart Flash card. The download is preferably arranged so that there is no permanent storage of downloaded data on the content access terminal (although temporary storage in a disk cache may be permissible), and there is further preferably no temporary storage on the content access terminal of complete data for a content data item. This provides data security and reassurance to the content providers.

[0123] In the same way as with card registration described with regard to Figure 11, a secure and trusted link is set up between the content access terminal and/or the smart Flash card and the data supply computer in a conventional manner as is well known to those skilled in the art (for example, using public key data encryption). The data transaction may be set up directly between the smart Flash card and the data supply computer, in which case the content access terminal has no access to unencrypted content data, or it may be set up between the content access terminal and the data supply computer, in which case unencrypted data is written by the content access terminal to the smart Flash card. Standard transmission protocols are used to ensure complete transmission of a content data item, for example by re-transmitting blocks of data which are not correctly received.

[0124] Also at step S57, one or more content access rules is received from the scheme-system owner data supply computer and written to the smart Flash card so that each content data item has an associated use rule to specify under what conditions a user of the smart Flash card is allowed access to the content data item.

[0125] At step S58 the content access terminal receives CRM data from the content distribution processor 134 of the scheme-system owner, for example specifying a number of reward points earned by downloading the selected content items. This CRM data will normally be written to the smart Flash card (step S59), but may additionally or alternatively be stored in the content access terminal or in a data store of the content access terminal owner so that the reward points are held by the distributor/retailer/cable TV operator. Finally, also at step S59, a complete record of details of the transactions between the smart Flash card and the content access terminal, the smart Flash card and the scheme-system owner, the smart Flash card and the e-payment system, and the content access terminal and the e-payment system and/or data supply computer is recorded on the smart Flash card to provide an audit trail. The system then returns to the menu display at step S42.

[0126] The add monetary value menu option provided by the menu operates in a similar manner to that described with regard to steps S15 and S16 of Figure 11a and steps S24 to S27 of Figure 11b. In embodiments of the system in which the smart Flash card operates either in a debit (pre-pay) or credit mode, operating mode data may be loaded from the card together with outlying CRM data at step S40. If the card is operating in a credit mode then, at step S41, the content access terminal reads content use data records from the card and proceeds correspondingly to steps S47 and S48 to determine the value of the content accessed and then proceeds according to steps S15 and S16 of Figure 11a and steps S24 to S27 of Figure 11b to retrieve payment for the accessed content from the card owner. Where enhanced access control features are provided, access control data read from the smart Flash card or entered into the content access terminal at step S31 is used, in step S44, to access the scheme-system owner content access webpage and, in some embodiments, to set up a secure connection between the content access terminal and scheme-system owner data supply computer at step S44.

[0127] Referring now to Figures 12d and 12e, these show steps in a process implemented on the scheme-system owner's data supply computer, for providing content data to a content access terminal and thence to a data carrier such as a smart Flash card. At step S60 the scheme-system owner's content access web page is requested by a content access terminal and transmitted to the requesting terminal. A search request for searching for a content data item is received, at step S61, from the content access terminal, and at step S62 content distribution processor 134 of the content supply system searches content access and DRM data store 140 and transmits the search results to the content access terminal. The search results will normally comprise a content item identifier, a content item description, optionally a content item sample, and at least one content item price, for example, for a default payment option. The search results may comprise a set of content data items, either selected by type or artist or comprising some predetermined selection in a similar manner to a compilation of tracks on a CD.

[0128] At step S63 content item selection data identifying one or more content items is retrieved from the content access terminal, and at step S64 content item purchase data for the selected content items is retrieved from content access and DRM data store 140. This purchase data will normally include, for each selected content item, one or more prices and

purchase options. Purchase option data may simply comprise one of a set of standard options, for example, "1" to purchase outright, "2" to rent for a period of time, "3" to rent for a number of plays, and "4" to rent with a final purchase option. The purchase option data may also indicate when a content item is available free.

[0129] At step S65 the content purchase data is transmitted to the content access terminal, and at step S66 payment record data, indicating a payment made from the smart Flash card to the scheme-system owner, purchase request data, card registration data and, optionally, access control data, is received from the content access terminal. The payment record data confirms a payment for the requested data items, the purchase request data specifies the payment option selected for the selected content items, and the card registration data provides data for keeping records of the transaction and providing reward points; the access control data may be required for additional data security. At step S67 the payment record data, in the described embodiment of the system, is validated with an e-payment system such as ~~E~~e-payment system 121 of Figure 6. As illustrated in the flow chart, the data supply system computer checks with the e-payment system that a payment has in fact been made to the scheme-system owner. In other embodiments of the system, payment may be made directly to the scheme-system owner, and either concurrently with the content access and download process, or at some later stage, payment data received from the smart Flash card may be verified with the e-payment system for reimbursement of the scheme-system owner.

[0130] At step S68, payment distribution data is read from the content access data store 140. This data will indicate how payment made by the card for the data is to be distributed among recipients. In one embodiment, recipients' payment fractions are specified in general terms in the content access data store, for example, copyright owner 0.90, scheme-system owner 0.01, retailer/distributor 0.02, publisher 0.02, creator 0.05. Identification of who is the relevant copyright owner is stored in the data store together with the content item identifier, but may be selected from more than one possible content ~~providers-provider~~ for the data item, and identification of who is the relevant retailer/distributor may be determined from, for example, content access identity information received from the content access terminal when the scheme-system owner content access web page is accessed at step S60. At step S69, payments are then distributed in accordance with the payment distribution data, either by direct distribution of value-bearing digital signatures to the relevant parties, or by issuing a

payment distribution instruction to e-payment system 121. Preferably the data supply system stores records of individual card payments and, at intervals, combines the payment distribution data for a plurality of individual records to output payment data for distributing the total payment received by the data supply system from a batch of individual payments.

[0131] At step S70, content access rules for the purchased level of service are read from the content access data store. These rules could, for example, specify that only a predetermined number of accesses to the content are permitted, for example 10 plays. Alternatively, the rules could provide access for, say, one month from the download date. Other rules may provide unlimited plays but only on specified players, for example, set top boxes owned by a particular cable TV network (as determined by content access device identification data provided to a smart Flash card from a content access device). A content provider identification for the requested content data is also read from the content access data store at step S70 together with CRM data for issuing reward points.

[0132] At step S71, content access rules for the requested content data items are retrieved from data store 140 and transmitted to the content access terminal. Then, at step S72, DRM processor 130 of the data supply system transmits a transaction request and authentication data to the content provider identified in step S70. This request identifies the ~~scheme-system~~ owner data supply system to the content provider in a secure manner, either by means of physical security, such as a dedicated connection from the ~~scheme-system~~ owner data supply system to the content provider, or by means of an electronically secure connection such as an encryption connection. Then, at step S73, the content access web server 124 receives protected content from the content provider, comprising the data items requested by the content access terminal, and transmits this protected content to the content access terminal. The content is preferably protected by data encryption but may be protected in other ways, for example, by digital watermarking or simply by the large number of other transactions taking place at any one time over the internet. The data supply system computer, at this point, essentially acts as a transparent data forwarder, forwarding data from the content provider to the content access terminal, which itself is preferably effectively transparent, using data exchange interface 200c to transmit the protected content data directly to the smart Flash card. As described with regard to Figure 12d, the content download protocol includes error

protection and transmission retry protocols to ensure substantially error-free data transmission.

[0133] Once content has been downloaded to the content access terminal (and, hence, to the smart Flash card) at step S74 a record of the purchase data and content accessed is written to payment record data store 136, to provide an audit trail. Then, at step S75, updated CRM data is written to the content access data store 140, using rules stored in the content access data store, in conjunction with a record of the downloaded data items, to calculate the CRM data (i.e. reward points). The updated CRM data is then also transmitted to the content access terminal, where it can be forwarded to the smart Flash card. Then, at step S76, the process ends.

[0134] Referring now to Figure 13, this shows a flow chart for user access of stored data on a smart Flash card using a data access device such as the MP3 player of Figure 1. At step S77 the smart Flash card is inserted into the player and, at step S78, the user enters a password into the player, which is transmitted to the smart Flash card for validation (this step is optional). If access to stored data on the card is permitted, the process proceeds to step S79 where an index of content data items stored on the card is loaded from the card and displayed together with a menu. The menu provides options including access content, check value (stored on the card), check CRM data (such as reward points) stored on the card, and play options (such as no video, repeat play, random play, and the like). If the user wishes to access content data items stored on the smart Flash card, a user selection of such items is entered into the player at step S80, for example using cursor keys or a pointer; additionally or alternatively a default play option may be provided to, for example, play the most recently downloaded data.

[0135] At step S81 content use status data for the selected content items is loaded from the smart Flash card together with associated content use rules. Then, at step S82, the use rules and present use status for each selected content item are compared and the result is displayed together with a content play menu. The content play menu may comprise a simple list of the selected content items with items not available for access highlighted in, for example, red. Alternatively, more detailed content access permission data may be displayed such as the purchased contents use for a content data item, the actual use of the data item made so far, and the available remaining use. Then, at step S83, the layer-player determines whether

content use is permitted. If use is not permitted, the process returns to step S79 to re-display the menu; if content use is permitted the system proceeds to step S84.

[0136] At step S84 the selected content data items whose use is permitted are retrieved sequentially from the card, decoded as necessary, and the decoded audio and/or video data is made available to the user, for example, by providing audio output at a headphone socket on the player and displaying video output on the player display. Preferably, the player also retrieves supplementary data stored in association with a content data item, such as advertising data, or for a web-enabled player, hot links to web sites for sale of goods or services, particularly those related to the accessed content data item or those identified to appeal to users accessing the data item (such as pop group ~~merchandising~~ merchandizing or Harley Davidson (trade mark) motor bikes for rock music/video).

[0137] Preferably, the player is provided with "pause" and "continue" functions and corresponding user controls. When "pause" is selected the process passes to step S85 and writes a record to the smart Flash card comprising data specifying how much use has been made of the accessed content data item. In the case of music or video data, this may comprise start and end time markers or simply a play duration time (the start time being predetermined, for example at the start of the data item). In the case of a game the partial use data may comprise an elapsed play time or a number of lives left. In the case of a data item providing a service such as access to stock and share prices, or weather information, or a share dealing service, the partial use information may comprise a status record indicating the status of an interrupted transaction. When the "continue" function is selected on the player the process returns to step S84.

[0138] To allow for the smart Flash card being removed from the player between pause and continue events, a check may be made at step S78, by reading a partial use status data from the card, to determine whether a content data item was left in a pause state when the card was ~~last~~ last used. If such a ~~paused~~ pause state is determined to exist for a content data item, the process may then jump directly to step S85 to allow a user to resume or continue with the content data item and proceed directly to step S84.

[0139] Once play is complete the process moves to step S85 where updated content use data is written to the smart Flash card. This updated use data provides a record of the use of a

content made in step S84. This record can then be used in steps S81 to S83 to determine, on a subsequent occasion, whether further use of the content data item is permitted. Finally, at step S86, customer reward management reward rules are loaded from the smart Flash card together with CRM data stored on the card. The CRM data is then updated, using the CRM reward rules, to reflect the use of content data items made in step S84 and the updated data is written back to the smart Flash card.

[0140] In one embodiment the CRM reward rules are determined by the content access terminal owner (retailer/distributor/cable or mobile network operator) and are written onto the card when registering the card. The updated CRM data may then be accessed by a content access terminal for spending or other use when the smart Flash card is next inserted into a content access terminal. Once the CRM data has been updated, the process returns to step S79 to display the content index and menu.

[0141] The specific embodiments of the invention described above use communication over the internet and web-based technology but this is not essential, and the invention may be implemented using any electronic communications network, such as a wide area network, local area network, wireless network, or conventional land line network. Likewise, the invention is applicable to the ~~Internet-internet~~, intranets, extranets, and other internet protocol networks.

[0142] The skilled person will understand that many variants to the system are possible and the invention is not limited to the described embodiments but encompasses modifications which lie within the spirit and scope of the present invention.

Further aspects of the invention are set out in the following clauses:

1. ~~A mobile data retrieval device comprising:
a removable data storage means;
data access means, to access downloaded data on the data storage means;
storage interface means adapted to couple the data storage and data access means; and
data output means to provide the downloaded data, in a useful form, to a user of the device;
wherein the data storage means further comprises payment validation means to validate payment for the downloaded data.~~
2. ~~A mobile data retrieval device as in clause 1 wherein the data storage means receives power from the retrieval device when connected to the device and retains storage by the downloaded data when unpowered.~~
3. ~~A mobile data retrieval device as in clause 1 or 2 wherein the data storage means comprises external data interface means to receive data downloaded from an external source onto the card for storage and wherein the payment validation means comprises means to validate payment to the external source.~~
4. ~~A mobile data retrieval device according to any preceding clause wherein the payment validation means comprises memory means to store transaction value information on a cash value of transactions validatable by the data storage means.~~
5. ~~A mobile data retrieval device according to any preceding clause wherein the payment validation means comprises memory means to store information to identify a payer for the downloaded data.~~
6. ~~A mobile data retrieval device according to any preceding clause wherein one of the data storage means and the retrieval device further comprises data description means to at least partially decrypt downloaded data.~~

- 7. — A mobile data retrieval device according to any preceding clause wherein one of the data storage means and the retrieval device comprises access control means to prevent unauthorised access to the downloaded data.
- 8. — A mobile data retrieval device according to clause 7 wherein the access control means is responsive to the payment validation means.
- 9. — A mobile data retrieval device according to any one of clauses 3 to 8 wherein the payment validation means comprises a payment validation means interface operable simultaneously with the external data interface means.
- 10. — A mobile data retrieval device according to any preceding clause wherein the data storage means comprises an electronic memory card or smart card.
- 11. — A mobile data retrieval device according to clause 10 having a housing with a slot therein to receive the data storage means.
- 12. — A mobile data retrieval device according to clause 11 further comprising local storage means and means to copy data from the data storage means into the local storage means.
- 13. — A mobile data retrieval device according to clause 11 or 12 wherein the retrieval device is portable and, in two directions, is not substantially larger than the data storage means.
- 14. — A mobile data retrieval device according to any preceding clause wherein the storage interface means is adapted for repeated removal and reconnection of the data storage means to the retrieval device.
- 15. — A mobile data retrieval device according to any preceding clause further comprising display means to display information derived from the downloaded data to the user.
- 16. — A mobile data retrieval device according to any preceding clause further comprising audio output means to provide an audio output corresponding to the downloaded data to the user.

17. ~~A mobile data retrieval device according to any preceding clause comprising a first set of contacts for the storage interface means and a second set of contacts for interfacing to the payment validation means.~~

18. ~~A data providing system comprising a mobile data retrieval device as in any preceding clause, and~~

~~a data access terminal to interface with the data storage means to download data and to co-operate with the payment validation means to validate payment for the downloaded data.~~

19. ~~A data providing system as in clause 18 wherein the data access terminal is coupleable to the internet and co-operates with the payment validation means to validate payment with a payment validation authority and is operable to download data to the data storage means from a data supplier on the internet.~~

20. ~~A data providing system as in claim 19 wherein the data access terminal operates through a data access service provider, the data access service provider being configured to communicate with the payment validation authority and to control access of data access terminal to data from the data supplier.~~

21. ~~A data storage means for use with the device or system of any preceding clause.~~

22. ~~A data storage means comprising an external data interface means to receive data downloaded from an external source onto the card for storage; and payment validation means comprising means to validate payment to the external source, and/or to a payment validation authority.~~

23. ~~A data storage means as in clause 22 further comprising data decryption means to at least partially decrypt the downloaded data.~~

24. ~~A data storage means as in clause 22 or 23 further comprising access control means to prevent unauthorised access to the downloaded data.~~

25. ~~A data storage means as in clause 24 wherein the access control means is responsive to the payment validation means.~~

~~26. A data storage means according to any one of clauses 22 to 25 wherein the payment validation means comprises a payment validation means interface operable simultaneously with the external data interface means.~~

~~27. A data storage means according to any one of clauses 22 to 26 wherein the data storage means comprises an electronic memory card or smart card.~~

60874915 v1



UNITED STATES PATENT AND TRADEMARK OFFICE

den

UNITED STATES DEPARTMENT OF COMMERCE
United States Patent and Trademark Office
Address: COMMISSIONER FOR PATENTS
P.O. Box 1450
Alexandria, Virginia 22313-1450
www.uspto.gov

| APPLICATION NO. | FILING DATE | FIRST NAMED INVENTOR | ATTORNEY DOCKET NO. | CONFIRMATION NO. |
|-----------------|-------------|----------------------|---------------------|------------------|
| 11/336,758 | 01/19/2006 | Hermen-ard Hulst | 080379-000100US | 3911 |

20350 7590 08/29/2006
TOWNSEND AND TOWNSEND AND CREW, LLP
TWO EMBARCADERO CENTER
EIGHTH FLOOR
SAN FRANCISCO, CA 94111-3834

EXAMINER

PAIK, STEVE S

ART UNIT PAPER NUMBER

2876

DATE MAILED: 08/29/2006

Please find below and/or attached an Office communication concerning this application or proceeding.

| | | | |
|------------------------------|--|-------------------------------------|--|
| Office Action Summary | Application No. 11/336,758 | Applicant(s) HULST ET AL. | |
| | Examiner Steven S. Paik | Art Unit 2876 | |
| | <p>– The MAILING DATE of this communication appears on the cover sheet with the correspondence address – Period for Reply</p> <p>A SHORTENED STATUTORY PERIOD FOR REPLY IS SET TO EXPIRE <u>1</u> MONTH(S) OR THIRTY (30) DAYS, WHICHEVER IS LONGER, FROM THE MAILING DATE OF THIS COMMUNICATION.</p> <ul style="list-style-type: none"> - Extensions of time may be available under the provisions of 37 CFR 1.136(a). In no event, however, may a reply be timely filed after SIX (6) MONTHS from the mailing date of this communication. - If NO period for reply is specified above, the maximum statutory period will apply and will expire SIX (6) MONTHS from the mailing date of this communication. - Failure to reply within the set or extended period for reply will, by statute, cause the application to become ABANDONED (35 U.S.C. § 133). Any reply received by the Office later than three months after the mailing date of this communication, even if timely filed, may reduce any earned patent term adjustment. See 37 CFR 1.704(b). | | |

Status

1) Responsive to communication(s) filed on 19 January 2006.

2a) This action is **FINAL**. 2b) This action is non-final.

3) Since this application is in condition for allowance except for formal matters, prosecution as to the merits is closed in accordance with the practice under *Ex parte Quayle*, 1935 C.D. 11, 453 O.G. 213.

Disposition of Claims

4) Claim(s) 1-74 is/are pending in the application.

 4a) Of the above claim(s) _____ is/are withdrawn from consideration.

5) Claim(s) _____ is/are allowed.

6) Claim(s) _____ is/are rejected.

7) Claim(s) _____ is/are objected to.

8) Claim(s) 1-74 are subject to restriction and/or election requirement.

Application Papers

9) The specification is objected to by the Examiner.

10) The drawing(s) filed on _____ is/are: a) accepted or b) objected to by the Examiner.
 Applicant may not request that any objection to the drawing(s) be held in abeyance. See 37 CFR 1.85(a).
 Replacement drawing sheet(s) including the correction is required if the drawing(s) is objected to. See 37 CFR 1.121(d).

11) The oath or declaration is objected to by the Examiner. Note the attached Office Action or form PTO-152.

Priority under 35 U.S.C. § 119

12) Acknowledgment is made of a claim for foreign priority under 35 U.S.C. § 119(a)-(d) or (f).

 a) All b) Some * c) None of:

 1. Certified copies of the priority documents have been received.

 2. Certified copies of the priority documents have been received in Application No. _____.

 3. Copies of the certified copies of the priority documents have been received in this National Stage application from the International Bureau (PCT Rule 17.2(a)).

 * See the attached detailed Office action for a list of the certified copies not received.

Attachment(s)

1) Notice of References Cited (PTO-892)

2) Notice of Draftsperson's Patent Drawing Review (PTO-948)

3) Information Disclosure Statement(s) (PTO-1449 or PTO/SB/08)
 Paper No(s)/Mail Date 1/19/06.

4) Interview Summary (PTO-413)
 Paper No(s)/Mail Date. _____.

5) Notice of Informal Patent Application (PTO-152)

6) Other: _____.

DETAILED ACTION

Election/Restrictions

1. Restriction to one of the following inventions is required under 35 U.S.C. 121:
 - I. Claims 1-9, drawn to a method of providing portable data, classified in class 235, subclass 487.
 - II. Claims 10-21, 51-58, 67, and 68 drawn to a portable data carrier, classified in class 23, subclass 379.
 - III. Claims 22, 23, 35-50, and 59-62 drawn to a method and an apparatus of controlling access to data, classified in class 235, subclass 382.
 - IV. Claims 24-34, 63-66, and 69-74 drawn to a system controlled by data bearing records, classified in class 235, subclass 375.
2. The inventions are distinct, each from the other because of the following reasons:

Inventions Group I - Group IV are related as product and process of use. The inventions can be shown to be distinct if either or both of the following can be shown: (1) the process for using the product as claimed can be practiced with another materially different product or (2) the product as claimed can be used in a materially different process of using that product (MPEP § 806.05(h)). In the instant case the process for using the product claimed can be practiced with materially different product.

Because these inventions are distinct for the reasons given above and have acquired a separate status in the art as shown by their different classification, restriction for examination purposes as indicated is proper.

Because these inventions are distinct for the reasons given above and the search required for Group I is not required for Groups II, III, or IV restriction for examination purposes as indicated is proper.

3. Applicant is reminded that upon the cancellation of claims to a non-elected invention, the inventorship must be amended in compliance with 37 CFR 1.48(b) if one or more of the currently named inventors is no longer an inventor of at least one claim remaining in the application. Any amendment of inventorship must be accompanied by a petition under 37 CFR 1.48(b) and by the fee required under 37 CFR 1.17(i).

Conclusion

Any inquiry concerning this communication or earlier communications from the examiner should be directed to Steven S. Paik whose telephone number is 571-272-2404. The examiner can normally be reached on Monday - Friday 5:30a-2:00p (Maxi-Flex*).

If attempts to reach the examiner by telephone are unsuccessful, the examiner's supervisor, Michael G. Lee can be reached on 571-272-2398. The fax phone number for the organization where this application or proceeding is assigned is 571-273-8300.

Information regarding the status of an application may be obtained from the Patent Application Information Retrieval (PAIR) system. Status information for published applications may be obtained from either Private PAIR or Public PAIR. Status information for unpublished applications is available through Private PAIR only. For more information about the PAIR system, see <http://pair-direct.uspto.gov>. Should you have questions on access to the Private PAIR system, contact the Electronic Business Center (EBC) at 866-217-9197 (toll-free). If you would

Application/Control Number: 11/336,758

Page 4

Art Unit: 2876

like assistance from a USPTO Customer Service Representative or access to the automated information system, call 800-786-9199 (IN USA OR CANADA) or 571-272-1000.

Steven S. Paik
Primary Examiner
Art Unit 2876

ssp

1/19/06

| | | | |
|--|------------------------|---------------------------------|--------------------------------|
| Substitute for form 1448A/PTO | | Complete If Known | |
| INFORMATION DISCLOSURE STATEMENT BY APPLICANT <i>(use as many sheets as necessary)</i> | | Application Number | 40444740 11/336,758 |
| | | Filing Date | September 17, 2002 |
| | | First Named Inventor | Hulst, Herman-Ard |
| | | Art Unit | 2876 |
| | | Examiner Name | Paik, Steve S. |
| Sheet 1 of 2 | Attorney Docket Number | 080379-000000US 080379-0001006S | |

| U.S. PATENT DOCUMENTS* | | | | | | |
|------------------------|-----------------------|-----------------|-----------------------------------|-----------------------------|---|---|
| Examiner Initials* | Cite No. ¹ | Document Number | | Publication Date MM-DD-YYYY | Name of Patentee or Applicant of Cited Document | Pages, Columns, Lines, Where Relevant Passages or Relevant Figures Appear |
| | | Number | Kind Code ² (if known) | | | |
| SSP | AA | US 5,228,145 | | 07/08/1993 | Moronaga et al. | |
| | AB | US 5,387,150 | | 11/22/1994 | Kitta et al. | |
| | AC | US 5,457,748 | | 10/10/1995 | Dolphin | |
| | AD | US 5,588,148 | | 12/24/1996 | Leroux | |
| | AE | US 5,877,953 | | 10/14/1997 | Dolphin | |
| | AF | US 5,703,951 | | 12/30/1997 | Dolphin | |
| | AG | US 5,754,654 | | 05/18/1998 | Hiroya et al. | |
| | AH | US 5,794,202 | | 08/11/1998 | Kim | |
| | AI | US 5,809,241 | | 08/15/1998 | Hanel et al. | |
| | AJ | US 5,847,372 | | 12/08/1998 | Kraft | |
| | AK | US 5,889,860 | | 03/30/1999 | Eiler et al. | |
| | AL | US 5,901,330 | | 11/04/1999 | Sun et al. | |
| | AM | US 5,918,213 | | 06/29/1999 | Bernard et al. | |
| | AN | US 5,923,884 | | 07/13/1999 | Peyret et al. | |
| | AO | US 6,012,634 | | 01/11/2000 | Brogan et al. | |
| | AP | US 6,078,917 | | 08/29/2000 | Paulsen et al. | |
| | AQ | US 6,119,945 | | 09/18/2000 | Muller et al. | |
| | AR | US-6,202,058 | | 03/13/2001 | Nuttall | |
| | AS | US-6,385,731 | | 05/07/2002 | Ananda | |
| | AT | US 6,424,875 | | 07/23/2002 | Walter et al. | |
| | AU | US 6,442,570 | | 08/27/2002 | Wu | |
| | AV | US 6,473,829 | | 10/28/2002 | Dahmen et al. | |
| | AW | US 6,510,236 | | 01/21/2003 | Crane et al. | |
| | AX | US-6,553,413 | | 04/22/2003 | Leighton et al. | |
| SSP | AY | US-6,574,643 | | 06/03/2003 | Walter et al. | |

| FOREIGN PATENT DOCUMENTS | | | | | | | | |
|--------------------------|-----------------------|---------------------------|---------------------|-----------------------------------|-----------------------------|---|---|----------------|
| Examiner Initials* | Cite No. ¹ | Foreign Patent Document | | | Publication Date MM-DD-YYYY | Name of Patentee or Applicant of Cited Document | Pages, Columns, Lines, Where Relevant Passages or Relevant Figures Appear | T ⁴ |
| | | Country Code ³ | Number ⁴ | Kind Code ⁵ (if known) | | | | |
| SSP | AZ | WO | 98/19237 | | 05/07/1998 | | <input type="checkbox"/> | |
| | BA | WO | 98/33343 | | 07/30/1998 | | <input type="checkbox"/> | |
| | BB | WO | 98/37526 | | 08/27/1998 | | <input type="checkbox"/> | |
| | BC | EP | 0195098 | | 10/03/1990 | | <input type="checkbox"/> | |
| | BD | EP | 0713198 | | 05/22/1996 | | <input type="checkbox"/> | |
| | BE | EP | 0823694 | | 02/11/1998 | | <input type="checkbox"/> | |
| | BF | EP | 0542298 | | 04/22/1998 | | <input type="checkbox"/> | |
| | BG | EP | 0843449 | | 05/07/1998 | | <input type="checkbox"/> | |
| SSP | BH | EP | 0914001 | | 05/06/1999 | | <input type="checkbox"/> | |

| | | | |
|--------------------|---------------|-----------------|------------|
| Examiner Signature | /Steven Paik/ | Date Considered | 08/22/2006 |
|--------------------|---------------|-----------------|------------|

* EXAMINER: Initial if reference considered, whether or not citation is in conformance with MPEP 609. Draw line through citation if not in conformance and not considered. Include copy of this form with next communication to applicant. ¹ Applicant's unique citation designation number (optional). ² Kind Codes of U.S. Patent Documents at www.uspto.gov or MPEP 801.04. ³ Enter Office that issued the document, by the two-letter code (WIPO Standard ST.3). ⁴ For Japanese patent documents, the indication of the year of the reign of the Emperor must precede the serial number of the patent document. ⁵ Kind of document by the appropriate symbols as indicated on the document under WIPO Standard ST. 19 if possible. ⁶ Applicant is to place a check mark here if English language Translation is attached.
60113553 v1

HULST HERMEN-ARD
 Application No.: Unassigned
 Page 3 2 of 2

PATENT

| FOREIGN PATENT DOCUMENTS | | | | | | | | |
|--------------------------------|-----------------------|---------------------------|---------------------|-----------------------------------|-----------------------------|---|---|----------------|
| Examiner Initials ⁶ | Cite No. ¹ | Foreign Patent Document | | | Publication Date MM-DD-YYYY | Name of Patentee or Applicant of Cited Document | Pages, Columns, Lines, Where Relevant Passages or Relevant Figures Appear | T ⁵ |
| | | Country Code ³ | Number ⁴ | Kind Code ² (if known) | | | | |
| SSP | AA | EP | 0713198 | A2 | 05/22/1998 | | | |
| | AB | EP | 0823694 | A1 | 02/11/1998 | | | |
| | AC | EP | 0843449 | A2 | 05/20/1998 | | | |
| | AD | EP | 0914001 | A1 | 05/08/1999 | | | |
| SSP | AE | WIPO | WO 98/19237 | A1 | 05/07/1998 | | | |
| | AF | | | | | | | |
| | AG | | | | | | | |
| | AH | | | | | | | |

| | | | |
|--------------------|---------------|-----------------|------------|
| Examiner Signature | /Steven Paik/ | Date Considered | 08/22/2006 |
|--------------------|---------------|-----------------|------------|

⁶ EXAMINER: Initial if reference considered, whether or not citation is in conformance with MPEP 609. Draw line through citation if not in conformance and not considered. Include copy of this form with next communication to applicant.

¹ Applicant's unique citation designation number (optional). ² Applicant is to place a check mark here if English language Translation is attached.

Burden Hour Statement: This form is estimated to take 2.0 hours to complete. Time will vary depending upon the needs of the individual case. Any comments on the amount of time you are required to complete this form should be sent to the Chief Information Officer, U.S. Patent and Trademark Office, Washington, DC 20231. DO NOT SEND FEES OR COMPLETED FORMS TO THIS ADDRESS. SEND TO: Assistant Commissioner for Patents, Washington, DC 20231.
 SF 1340359 v1

Index of Claims



Application/Control No.

11/336,758

Examiner

Steven S. Paik

Applicant(s)/Patent under Reexamination

HULST ET AL.

Art Unit

2876

| | |
|---|----------|
| √ | Rejected |
| ≡ | Allowed |

| | |
|---|--------------------------------|
| — | (Through numeral) Cancelled |
| + | Restricted |

| | |
|---|--------------|
| N | Non-Elected |
| I | Interference |

| | |
|---|----------|
| A | Appeal |
| O | Objected |

| Claim | | Date | |
|-------|----------|------|--|
| Final | Original | | |
| | 8/22/06 | | |
| 1 | | | |
| 2 | | | |
| 3 | | | |
| 4 | | | |
| 5 | | | |
| 6 | | | |
| 7 | | | |
| 8 | | | |
| 9 | | | |
| 10 | | | |
| 11 | | | |
| 12 | | | |
| 13 | | | |
| 14 | | | |
| 15 | | | |
| 16 | | | |
| 17 | | | |
| 18 | | | |
| 19 | | | |
| 20 | | | |
| 21 | | | |
| 22 | | | |
| 23 | | | |
| 24 | | | |
| 25 | | | |
| 26 | | | |
| 27 | | | |
| 28 | | | |
| 29 | | | |
| 30 | | | |
| 31 | | | |
| 32 | | | |
| 33 | | | |
| 34 | | | |
| 35 | | | |
| 36 | | | |
| 37 | | | |
| 38 | | | |
| 39 | | | |
| 40 | | | |
| 41 | | | |
| 42 | | | |
| 43 | | | |
| 44 | | | |
| 45 | | | |
| 46 | | | |
| 47 | | | |
| 48 | | | |
| 49 | | | |
| 50 | | | |

| Claim | | Date | |
|-------|----------|------|--|
| Final | Original | | |
| | 8/22/06 | | |
| 51 | | | |
| 52 | | | |
| 53 | | | |
| 54 | | | |
| 55 | | | |
| 56 | | | |
| 57 | | | |
| 58 | | | |
| 59 | | | |
| 60 | | | |
| 61 | | | |
| 62 | | | |
| 63 | | | |
| 64 | | | |
| 65 | | | |
| 66 | | | |
| 67 | | | |
| 68 | | | |
| 69 | | | |
| 70 | | | |
| 71 | | | |
| 72 | | | |
| 73 | | | |
| 74 | | | |
| 75 | | | |
| 76 | | | |
| 77 | | | |
| 78 | | | |
| 79 | | | |
| 80 | | | |
| 81 | | | |
| 82 | | | |
| 83 | | | |
| 84 | | | |
| 85 | | | |
| 86 | | | |
| 87 | | | |
| 88 | | | |
| 89 | | | |
| 90 | | | |
| 91 | | | |
| 92 | | | |
| 93 | | | |
| 94 | | | |
| 95 | | | |
| 96 | | | |
| 97 | | | |
| 98 | | | |
| 99 | | | |
| 100 | | | |

| Claim | | Date | |
|-------|----------|------|--|
| Final | Original | | |
| 101 | | | |
| 102 | | | |
| 103 | | | |
| 104 | | | |
| 105 | | | |
| 106 | | | |
| 107 | | | |
| 108 | | | |
| 109 | | | |
| 110 | | | |
| 111 | | | |
| 112 | | | |
| 113 | | | |
| 114 | | | |
| 115 | | | |
| 116 | | | |
| 117 | | | |
| 118 | | | |
| 119 | | | |
| 120 | | | |
| 121 | | | |
| 122 | | | |
| 123 | | | |
| 124 | | | |
| 125 | | | |
| 126 | | | |
| 127 | | | |
| 128 | | | |
| 129 | | | |
| 130 | | | |
| 131 | | | |
| 132 | | | |
| 133 | | | |
| 134 | | | |
| 135 | | | |
| 136 | | | |
| 137 | | | |
| 138 | | | |
| 139 | | | |
| 140 | | | |
| 141 | | | |
| 142 | | | |
| 143 | | | |
| 144 | | | |
| 145 | | | |
| 146 | | | |
| 147 | | | |
| 148 | | | |
| 149 | | | |
| 150 | | | |



UNITED STATES PATENT AND TRADEMARK OFFICE

UNITED STATES DEPARTMENT OF COMMERCE
 United States Patent and Trademark Office
 Address: COMMISSIONER FOR PATENTS
 P.O. Box 1459
 Alexandria, Virginia 22313-1450
 www.uspto.gov



Bib Data Sheet

CONFIRMATION NO. 3911

| | | | | |
|------------------------------------|--|---------------------|-------------------------------|---|
| SERIAL NUMBER 11/336,758 | FILING OR 371 (c) DATE 01/19/2006 RULE | CLASS 235 | GROUP ART UNIT 2876 | ATTORNEY DOCKET NO. 080379-000100US |
|------------------------------------|--|---------------------|-------------------------------|---|

APPLICANTS
 Hermen-ard Hulst, Amsterdam, NETHERLANDS;
 Patrick Sandor Racz, St. Heller, UNITED KINGDOM;

**** CONTINUING DATA ******* *SSP*
 This application is a CON of 10/111,716 09/17/2002 which is a 371 of PCT/GB00/04110 10/25/2000
Verified

**** FOREIGN APPLICATIONS ******* *SSP*
 UNITED KINGDOM 9925227.2 11/25/1999
Verified

IF REQUIRED, FOREIGN FILING LICENSE ** SMALL ENTITY **
GRANTED ** 03/01/2006

| | | | | |
|---|--|-----------------------------|---------------------------|---------------------------------|
| Foreign Priority claimed <input checked="" type="checkbox"/> yes <input type="checkbox"/> no 35 USC 119 (a-d) conditions met <input type="checkbox"/> yes <input checked="" type="checkbox"/> no <input type="checkbox"/> Met after Allowance Verified and Acknowledged <i>SSP</i> Examiner's Signature <i>SSP</i> Initials | STATE OR COUNTRY NETHERLANDS | SHEETS DRAWING 17 | TOTAL CLAIMS 74 | INDEPENDENT CLAIMS 16 |
|---|--|-----------------------------|---------------------------|---------------------------------|

ADDRESS
20350

TITLE
Data storage and access systems

| | | |
|------------------------------------|---|--|
| FILING FEE RECEIVED 3150 | FEES: Authority has been given in Paper No. _____ to charge/credit DEPOSIT ACCOUNT No. _____ for following: | <input type="checkbox"/> All Fees |
| | | <input type="checkbox"/> 1.16 Fees (Filing) |
| | | <input type="checkbox"/> 1.17 Fees (Processing Ext. of time) |
| | | <input type="checkbox"/> 1.18 Fees (Issue) |
| | | <input type="checkbox"/> Other _____ |
| | | <input type="checkbox"/> Credit |

17224
U.S. PTO
011906

PTO/SB/05 (05-05)

| | | |
|---|------------------------|---------------------------------|
| UTILITY PATENT APPLICATION TRANSMITTAL <small>(Only for new nonprovisional applications under 37 CFR 1.53(b))</small> | Attorney Docket No. | 080379-000100US |
| | First Inventor | Hulst, Hermen-ard |
| | Title | DATA STORAGE AND ACCESS SYSTEMS |
| | Express Mail Label No. | EV 383391336 US |

| | |
|---|--|
| <p style="text-align: center;">APPLICATION ELEMENTS</p> <p><small>See MPEP chapter 600 concerning utility patent application contents.</small></p> <p>1. <input checked="" type="checkbox"/> Fee Transmittal Form (e.g., PTO/SB/17) <small>(Submit an original and a duplicate for fee processing)</small></p> <p>2. <input checked="" type="checkbox"/> Applicant claims small entity status. <small>See 37 CFR 1.27.</small></p> <p>3. <input checked="" type="checkbox"/> Specification [Total Pages <u>61</u>] <small>Both the claims and abstract must start on a new page (For information on the preferred arrangement, see MPEP 608.01(a))</small></p> <p>4. <input checked="" type="checkbox"/> Drawing(s) (35 U.S.C. 113) [Total Sheets <u>17</u>]</p> <p>5. Oath or Declaration [Total Sheets <u>2</u>]</p> <p>a. <input type="checkbox"/> Newly executed (original or copy)</p> <p>b. <input checked="" type="checkbox"/> A copy from a prior application (37 CFR 1.63 (d)) <small>(for a continuation/divisional with Box 18 completed)</small></p> <p>i. <input type="checkbox"/> DELETION OF INVENTOR(S) <small>Signed statement attached deleting inventor(s) named in the prior application, see 37 CFR 1.63(d)(2) and 1.33(b).</small></p> <p>6. <input checked="" type="checkbox"/> Application Data Sheet. See 37 CFR 1.76</p> <p>7. <input type="checkbox"/> CD-ROM or CD-R in duplicate, large table or Computer Program (Appendix) <input type="checkbox"/> Landscape Table on CD</p> <p>8. Nucleotide and/or Amino Acid Sequence Submission <small>(if applicable, items a. - c. are required)</small></p> <p>a. Computer Readable Form (CRF)</p> <p>i. <input type="checkbox"/> Computer Readable Form (CRF)</p> <p>ii. <input type="checkbox"/> Transfer Request (37 CFR 1.821(e))</p> <p>b. Specification Sequence Listing on:</p> <p>i. <input type="checkbox"/> CD-ROM or CD-R (2 copies); or</p> <p>ii. <input type="checkbox"/> Paper</p> <p>c. <input type="checkbox"/> Statements verifying identity of above copies</p> | <p>ADDRESS TO: Commissioner for Patents P.O. Box 1450 Alexandria, VA 22313-1450</p> <p style="text-align: center;">ACCOMPANYING APPLICATION PARTS</p> <p>9. <input checked="" type="checkbox"/> Assignment Papers (cover sheet & document(s)) Name of Assignee <u>Smart-Flash Limited</u></p> <p>10. <input type="checkbox"/> 37 CFR 3.73(b) Statement <input type="checkbox"/> Power of Attorney <small>(when there is an assignee)</small></p> <p>11. <input type="checkbox"/> English Translation Document (if applicable)</p> <p>12. <input checked="" type="checkbox"/> Information Disclosure Statement (PTO/SB/08 or PTO-1449) <input checked="" type="checkbox"/> Copies of foreign patent documents, publications, & other information</p> <p>13. <input type="checkbox"/> Preliminary Amendment</p> <p>14. <input checked="" type="checkbox"/> Return Receipt Postcard (MPEP 503) <small>(Should be specifically itemized)</small></p> <p>15. <input type="checkbox"/> Certified Copy of Priority Document(s) <small>(if foreign priority is claimed)</small></p> <p>16. <input type="checkbox"/> Nonpublication Request under 35 U.S.C. 122 (b)(2)(B)(i). Applicant must attach form PTO/SB/35 or its equivalent.</p> <p>17. <input type="checkbox"/> Other: _____</p> |
|---|--|

18. If a CONTINUING APPLICATION, check appropriate box, and supply the requisite information below and in the first sentence of the specification following the title, or in an Application Data Sheet under 37 CFR 1.76:

Continuation Divisional Continuation-in-part (CIP) of prior application No: 10/111,716

Prior application information: Examiner S. Paik Art Unit: 2878

19. CORRESPONDENCE ADDRESS

The address associated with Customer Number: 20350 OR Correspondence address below

| | | | |
|---------|-----------|---------------|--|
| Name | | | |
| Address | | | |
| City | State | Zip Code | |
| Country | Telephone | Email Address | |

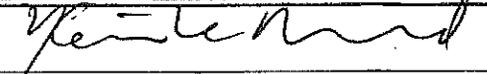
| | | | |
|-------------------|---|-----------------------------------|----------|
| Signature |  | Date | 01/19/06 |
| Name (Print/Type) | Kevin T. LeMond | Registration No. (Attorney/Agent) | 35,933 |

06682954 v1

| | | | |
|--|--|--------------------------|-------------------|
| Effective on 12/08/2004. Fees pursuant to the Consolidated Appropriations Act, 2005 (H.R. 4818). <h2 style="text-align: center;">FEE TRANSMITTAL</h2> <h3 style="text-align: center;">For FY 2006</h3> | | <i>Complete if Known</i> | |
| | | Application Number | |
| <input checked="" type="checkbox"/> Applicant claims small entity status. See 37 CFR 1.27 | | Filing Date | January 19, 2006 |
| | | First Named Inventor | Hulst, Hermen-ard |
| TOTAL AMOUNT OF PAYMENT (\$) 2950 | | Examiner Name | |
| | | Art Unit | |
| | | Attorney Docket No. | 080379-000100US |

METHOD OF PAYMENT (check all that apply)

Check
 Credit Card
 Money Order
 None
 Other (please identify): _____

Deposit Account
 Deposit Account Number: 20-1430
 Deposit Account Name: Townsend and Townsend and Crew LLP

For the above-identified deposit account, the Director is hereby authorized to: (check all that apply)

Charge fee(s) indicated below
 Charge fee(s) indicated below, except for the filing fee

Charge any additional fee(s) or underpayments of fee(s) under 37 CFR 1.16 and 1.17
 Credit any overpayments

WARNING: Information on this form may become public. Credit card information should not be included on this form. Provide credit card information and authorization on PTO-2038

FEE CALCULATION

1. BASIC FILING, SEARCH, AND EXAMINATION FEES

| Application Type | FILING FEES | | SEARCH FEES | | EXAMINATION FEES | | Fees Paid (\$) |
|------------------|-------------|-----------------------|-------------|-----------------------|------------------|-----------------------|----------------|
| | Fee (\$) | Small Entity Fee (\$) | Fee (\$) | Small Entity Fee (\$) | Fee (\$) | Small Entity Fee (\$) | |
| Utility | 300 | 150 | 500 | 250 | 200 | 100 | 500 |
| Design | 200 | 100 | 100 | 50 | 130 | 65 | |
| Plant | 200 | 100 | 300 | 150 | 160 | 80 | |
| Reissue | 300 | 150 | 500 | 250 | 600 | 300 | |
| Provisional | 200 | 100 | 0 | 0 | 0 | 0 | |

2. EXCESS CLAIM FEES

| Fee Description | Small Entity | |
|---|--------------|----------|
| | Fee (\$) | Fee (\$) |
| Each claim over 20 or, for Reissues, each claim over 20 and more than in the original patent | 50 | 25 |
| Each independent claim over 3 or, for Reissues, each independent claim more than in the original patent | 200 | 100 |
| Multiple dependent claims | 360 | 180 |

| Total Claims | Extra Claims | Fee (\$) | Fee Paid (\$) | Multiple Dependent Claims | Fee (\$) | Fee Paid (\$) |
|--------------|----------------|----------|---------------|---------------------------|----------|---------------|
| 74 | -20 or HP = 54 | x \$25 | = \$1,350 | | | |

HP = highest number of total claims paid for, if greater than 20

| Indep. Claims | Extra Claims | Fee (\$) | Fee Paid (\$) |
|---------------|---------------|----------|---------------|
| 14 | -3 or HP = 11 | x \$100 | = \$1,100 |

HP = highest number of independent claims paid for, if greater than 3

3. APPLICATION SIZE FEE

If the specification and drawings exceed 100 sheets of paper, the application size fee due is \$250 (\$125 for small entity) for each additional 50 sheets or fraction thereof. See 35 U.S.C. 41(a)(1)(G) and 37 CFR 1.16(s).

| Total Sheets | Extra Sheets | Number of each additional 50 or fraction thereof | Fee (\$) | Fee Paid (\$) |
|--------------|--------------|--|--------------------------------|---------------|
| | - 100 = | / 50 = | (round up to a whole number) x | = |

4. OTHER FEE(S)

Non-English Specification, \$130 fee (no small entity discount)

Other: _____

SUBMITTED BY

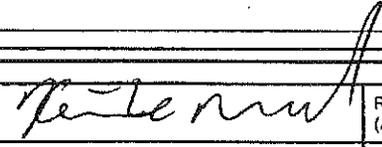
| | | | | | |
|-------------------|---|-----------------------------------|----------|-----------|--------------|
| Signature |  | Registration No. (Attorney/Agent) | 35,933 | Telephone | 415-576-0200 |
| Name (Print/Type) | Kevin T. LeMond | Date | 01/19/06 | | |

17224
U.S. PTO
011906

PTO/SB/05 (05-05)

| | | |
|---|------------------------|---------------------------------|
| UTILITY PATENT APPLICATION TRANSMITTAL <small>(Only for new nonprovisional applications under 37 CFR 1.53(b))</small> | Attorney Docket No. | 080379-000100US |
| | First Inventor | Hulst, Hermen-ard |
| | Title | DATA STORAGE AND ACCESS SYSTEMS |
| | Express Mail Label No. | EV 383391336 US |

| | |
|--|---|
| APPLICATION ELEMENTS <small>See MPEP chapter 600 concerning utility patent application contents.</small> | ADDRESS TO: Commissioner for Patents P.O. Box 1450 Alexandria, VA 22313-1450 |
|--|---|

| | |
|---|--|
| <p>1. <input checked="" type="checkbox"/> Fee Transmittal Form (e.g., PTO/SB/17) <i>(Submit an original and a duplicate for fee processing)</i></p> <p>2. <input checked="" type="checkbox"/> Applicant claims small entity status. See 37 CFR 1.27.</p> <p>3. <input checked="" type="checkbox"/> Specification [Total Pages <u>61</u>] Both the claims and abstract must start on a new page <i>(For information on the preferred arrangement, see MPEP 608.01(a))</i></p> <p>4. <input checked="" type="checkbox"/> Drawing(s) (35 U.S.C. 113) [Total Sheets <u>17</u>]</p> <p>5. Oath or Declaration [Total Sheets <u>2</u>] a. <input type="checkbox"/> Newly executed (original or copy) b. <input checked="" type="checkbox"/> A copy from a prior application (37 CFR 1.63 (d)) <i>(for a continuation/divisional with Box 18 completed)</i> i. <input type="checkbox"/> DELETION OF INVENTOR(S) Signed statement attached deleting inventor(s) named in the prior application, see 37 CFR 1.63(d)(2) and 1.33(b).</p> <p>6. <input checked="" type="checkbox"/> Application Data Sheet. See 37 CFR 1.76</p> <p>7. <input type="checkbox"/> CD-ROM or CD-R in duplicate, large table or Computer Program <i>(Appendix)</i> <input type="checkbox"/> Landscape Table on CD</p> <p>8. Nucleotide and/or Amino Acid Sequence Submission <i>(if applicable, items a. - c. are required)</i> a. Computer Readable Form (CRF) i. <input type="checkbox"/> Computer Readable Form (CRF) ii. <input type="checkbox"/> Transfer Request (37 CFR 1.821(e)) b. Specification Sequence Listing on: i. <input type="checkbox"/> CD-ROM or CD-R (2 copies); or ii. <input type="checkbox"/> Paper c. <input type="checkbox"/> Statements verifying identity of above copies</p> | <p style="text-align: center;">ACCOMPANYING APPLICATION PARTS</p> <p>9. <input checked="" type="checkbox"/> Assignment Papers (cover sheet & document(s)) Name of Assignee <u>Smart-Flash Limited</u></p> <p>10. <input type="checkbox"/> 37 CFR 3.73(b) Statement <input type="checkbox"/> Power of Attorney <i>(when there is an assignee)</i></p> <p>11. <input type="checkbox"/> English Translation Document <i>(if applicable)</i></p> <p>12. <input checked="" type="checkbox"/> Information Disclosure Statement (PTO/SB/08 or PTO-1449) <input checked="" type="checkbox"/> Copies of foreign patent documents, publications, & other information</p> <p>13. <input type="checkbox"/> Preliminary Amendment</p> <p>14. <input checked="" type="checkbox"/> Return Receipt Postcard (MPEP 503) <i>(Should be specifically itemized)</i></p> <p>15. <input type="checkbox"/> Certified Copy of Priority Document(s) <i>(if foreign priority is claimed)</i></p> <p>16. <input type="checkbox"/> Nonpublication Request under 35 U.S.C. 122 (b)(2)(B)(i). Applicant must attach form PTO/SB/35 or its equivalent.</p> <p>17. <input type="checkbox"/> Other: _____</p> |
|---|--|

18. If a CONTINUING APPLICATION, check appropriate box, and supply the requisite information below and in the first sentence of the specification following the title, or in an Application Data Sheet under 37 CFR 1.76:

Continuation Divisional Continuation-in-part (CIP) of prior application No: 10/111,716

Prior application information: Examiner S. Paik Art Unit: 2876

19. CORRESPONDENCE ADDRESS

The address associated with Customer Number: 20350 OR Correspondence address below

| | | | |
|---------|-----------|---------------|--|
| Name | | Address | |
| City | State | Zip Code | |
| Country | Telephone | Email Address | |

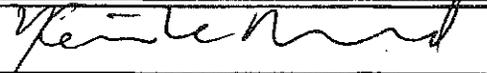
| | | | |
|-------------------|---|-----------------------------------|----------|
| Signature |  | Date | 01/19/06 |
| Name (Print/Type) | Kevin T. LeMond | Registration No. (Attorney/Agent) | 35,933 |

60682954 v1

| | | | |
|---|-----------|--------------------------|-------------------|
| Effective on 12/08/2004. Fees pursuant to the Consolidated Appropriations Act, 2005 (H.R. 4818). | | Complete if Known | |
| FEE TRANSMITTAL | | Application Number | |
| | | Filing Date | January 19, 2006 |
| For FY 2006 | | First Named Inventor | Hulst, Hermen-ard |
| | | Examiner Name | |
| <input checked="" type="checkbox"/> Applicant claims small entity status. See 37 CFR 1.27 | | Art Unit | |
| TOTAL AMOUNT OF PAYMENT | (\$) 2950 | Attorney Docket No. | 080379-000100US |

METHOD OF PAYMENT (check all that apply)

Check Credit Card Money Order None Other (please identify): _____
 Deposit Account Deposit Account Number: 20-1430 Deposit Account Name: Townsend and Townsend and Crew LLP
 For the above-identified deposit account, the Director is hereby authorized to: (check all that apply)
 Charge fee(s) indicated below Charge fee(s) indicated below, except for the filing fee
 Charge any additional fee(s) or underpayments of fee(s) under 37 CFR 1.16 and 1.17 Credit any overpayments

WARNING: Information on this form may become public. Credit card information should not be included on this form. Provide credit card information and authorization on PTO-2038

FEE CALCULATION**1. BASIC FILING, SEARCH, AND EXAMINATION FEES**

| Application Type | FILING FEES | | SEARCH FEES | | EXAMINATION FEES | | Fees Paid (\$) |
|------------------|-----------------------|----------|-----------------------|----------|-----------------------|----------|----------------|
| | Small Entity Fee (\$) | Fee (\$) | Small Entity Fee (\$) | Fee (\$) | Small Entity Fee (\$) | Fee (\$) | |
| Utility | 300 | 150 | 500 | 250 | 200 | 100 | 500 |
| Design | 200 | 100 | 100 | 50 | 130 | 65 | |
| Plant | 200 | 100 | 300 | 150 | 160 | 80 | |
| Reissue | 300 | 150 | 500 | 250 | 600 | 300 | |
| Provisional | 200 | 100 | 0 | 0 | 0 | 0 | |

2. EXCESS CLAIM FEES

| Fee Description | Small Entity | |
|---|--------------|----------|
| | Fee (\$) | Fee (\$) |
| Each claim over 20 or, for Reissues, each claim over 20 and more than in the original patent | 50 | 25 |
| Each independent claim over 3 or, for Reissues, each independent claim more than in the original patent | 200 | 100 |
| Multiple dependent claims | 360 | 180 |

| Total Claims | Extra Claims | Fee (\$) | Fee Paid (\$) | Multiple Dependent Claims | Fee (\$) | Fee Paid (\$) |
|--------------|----------------|----------|---------------|---------------------------|----------|---------------|
| 74 | -20 or HP = 54 | x \$25 = | \$1,350 | | | |

HP = highest number of total claims paid for, if greater than 20

| Indep. Claims | Extra Claims | Fee (\$) | Fee Paid (\$) |
|---------------|---------------|-----------|---------------|
| 14 | -3 or HP = 11 | x \$100 = | \$1,100 |

HP = highest number of independent claims paid for, if greater than 3

3. APPLICATION SIZE FEE

If the specification and drawings exceed 100 sheets of paper, the application size fee due is \$250 (\$125 for small entity) for each additional 50 sheets or fraction thereof. See 35 U.S.C. 41(a)(1)(G) and 37 CFR 1.16(s).

| Total Sheets | Extra Sheets | Number of each additional 50 or fraction thereof | Fee (\$) | Fee Paid (\$) |
|--------------|--------------|--|--------------------------------|---------------|
| | - 100 = | / 50 = | (round up to a whole number) x | = |

4. OTHER FEE(S)

Non-English Specification, \$130 fee (no small entity discount)

Other: _____

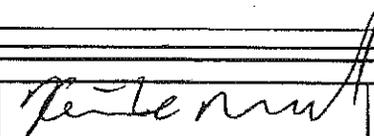
| | | | |
|---------------------|---|-----------------------------------|--------------|
| SUBMITTED BY | | | |
| Signature |  | Registration No. (Attorney/Agent) | 35,933 |
| Name (Print/Type) | Kevin T. LeMond | Telephone | 415-576-0200 |
| | | Date | 01/19/06 |

60683003 v1

DATA STORAGE AND ACCESS SYSTEMS

This invention is generally concerned with data storage and access systems. More particularly, it relates to a portable data carrier for storing and paying for data and to computer systems for providing access to data to be stored. The invention also includes corresponding methods and computer programs. The invention is particularly useful for managing stored audio and video data, but may also be applied to storage and access of text and software, including games, as well as other types of data.

One problem associated with the increasingly wide use of the internet is the growing prevalence of so-called data pirates. Such pirates obtain data either by unauthorised or legitimate means and then make this data available essentially world-wide over the internet without authorisation. Data can be a very valuable commodity, but once it has been published on the Internet it is difficult to police access to and use of it by Internet users who may not even realise that it is pirated. This is a particular problem with audio recordings, and, once the bandwidth becomes available, is also likely to be evident with video.

Over the past three or four years compressed audio sources have become increasingly widely available on web pages. One widely used audio data compression format is MP3 (MPEG3) which is an internationally defined standard including a definition of compressed audio information such as speech or music. It relies on psycho-acoustic properties of human hearing to achieve very large data compression factors. It is thus feasible to download usefully long passages of music in a practically convenient short time. Pirate data suppliers have not been slow to realise the potential of this and many unauthorised websites have sprung up offering popular music including recent releases by world famous bands. This has caused the recording industry considerable concern and there is an urgent need to find a way to address the problem of data piracy.

SUBSTITUTE SHEET (RULE 26)

BEST AVAILABLE COPY

The invention described below addresses this and related problems.

According to the present invention there is therefore provided a method of providing portable data comprising providing a portable data storage device comprising downloaded data storage means and payment validation means; providing a terminal for internet access; coupling the portable data storage device to the terminal; reading payment information from the payment validation means using the terminal; validating the payment information; and downloading data into the portable storage device from a data supplier.

Another aspect of the invention provides a corresponding mobile data retrieval device for retrieving and outputting data such as stored music and/or noise from the data storage device.

The payment validation means is, for example, means to validate payment with an external authority such as a bank or building society. The combination of the payment validation means with the data storage means allows the access to the downloaded data which is to be stored by the data storage means, to be made conditional upon checked and validated payment being made for the data. Binding the data access and payment together allows the legitimate owners of the data to make the data available themselves over the internet without fear of loss of revenue, thus undermining the position of data pirates.

A further advantage of the system is that it allows users under the age of 18 to make internet purchases. Currently internet users pay for goods and/or services by credit card. Since credit cards cannot be legitimately be used by persons under the age of 18 (at least in the UK), a significant fraction of adventurous internet users are excluded from e-commerce, one of the most significant predicted uses of the internet. In one embodiment of the invention however, the payment validation means comprises e-cash - that is the payment validation means stores transaction value information on a cash

value of transactions validatable by the data storage means. In simple terms, the data storage means can be a card which is charged up to a desired cash value (if necessary limited to a maximum value) at a suitable terminal. This might be an internet access terminal but could, more simply, be a device to accept the data storage card and to receive and count money deposited by the user to charge the card, writing update cash value information onto the card. More sophisticated ways of updating the cash value on the card are also possible, such as direct bank transfer. Since, with this type of embodiment, the data storage means is, essentially, precharged with cash rather than acting as a credit card it can be used by young people without the risk of their incurring large debts.

In one embodiment the data storage means is powered by the retrieval device when it is connected to the device and retains a memory of the downloaded data when it is unpowered. This can be achieved by the use of Flash RAM or, more generally, any form of programmable read-only memory. Alternatively the data storage means may incorporate a rechargeable cell or capacitor and store information in battery backed-up static RAM.

The downloaded data maybe entered into the data storage device by means of an interface such as a magnetically or capacitatively coupled connection or an optical connection, but preferably the interface comprises contacts for direct electrical connection to the storage means. The payment validation means may likewise have one of a variety of interfaces but again preferably comprises a set of electrical contacts. The payment validation means could, however comprise a magnetic or holographic data-strip such as is known for use with credit cards and phone cards. The interface to receive the downloaded data may be separate from the interface to the payment validation means, to facilitate separate and simultaneous access to both these systems. In other embodiments a single interface may serve for both data storage and payment. Advantageously the payment validation means includes a memory storing information to identify the person who is paying for the downloaded data.

For additional security the downloaded data may be encrypted. In this case data decryption may be necessary at some stage, either in the data storage means or in the retrieval device or in an information delivering apparatus such as a data access terminal. Alternatively the data decryption function can be shared amongst one or more of these devices. The skilled person will be aware of a range of suitable encryption/decryption techniques including Pretty Good Privacy (Registered Trade Mark) and PKI (Public Key Infrastructure). Normally when the downloaded data is encrypted a decryption key must be supplied. This can be generated automatically by the data access terminal or data access service provider or it can be entered by the user into the data access terminal or into the mobile data retrieval device.

The data storage means and/or the retrieval device can be provided with access control means to prevent unauthorised access to the downloaded data. Additionally or alternatively, use control means can be provided to stop or provide only limited access of the user to the downloaded data in accordance with the amount paid. These access and use control functions may in some embodiments be combined, permitted use controlling access or permitted access controlling use. Thus, for example, a complete set of data information relating to a particular topic, a particular music track, or a particular software package might be downloaded, although access to part of the data set might thereafter be controlled by payments made by a user at a later stage. In this way, a user could pay to enable an extra level on a game or to enable further tracks of an album.

In embodiments where the access or use control means is responsive to the payment validation means, access or use control information may be stored with the downloaded data or in a separate storage area, for example in the payment validation means. The user's access to the downloaded data could advantageously be responsive to the payment validation means, for example, by means of a control line coupling the payment validation means with a memory access or decryption control element.

In one embodiment the data storage means comprises an electronic memory card or smart card and the mobile data retrieval device is provided with a slot to receive the card. Preferably the card is a push-fit within the retrieval device, and retention of the card may be effected by pressure from electrical interface connections and/or resilience of the housing, or by using a resilient retaining means. In a preferred embodiment the retrieval device includes an audio output and a display, to play a downloaded track and to show information about the track and/or an accompanying video.

To download data onto the data storage means the user can employ a data access terminal coupled to the internet. The terminal can directly validate payment - for example in the case of a smart card charged with electronic cash it can deduct a cash value from the card. Alternatively it can communicate with a bank or other financial services provider to control payment. In a preferred embodiment, however, the terminal connects to a data access service provider which provides a portal to other sites and which validates payment and then forwards data from a data supplier to the user's local access terminal. The data access service provider may alternatively forward payment validation information and/or information from the payment validation authority to the data supplier for control by the supplier of the data supplied. Thus, access to the payment validation system and/or data for downloading may be entirely controlled by the data supplier.

Data held on the data storage means may advantageously include data relating to the user's or payer's usage of the system. This information may include, for example, information on a user's spending pattern, information on data suppliers used and information on the downloaded data. This information may be accessed by the data supplier and/or data access service provider and can be used for targeted marketing or loyalty-based incentive schemes such as air miles or the like.

The data access terminal may be a conventional computer or, alternatively, it may be a mobile phone. Wireless Application Protocol (WAP) and i-mode allow mobile phones to efficiently access the internet and this allows a mobile phone to be used to download

data to the data storage means, advantageously, directly. The data storage means can, if desired, incorporate the functionality of a mobile phone SIM (Subscriber Identity Module) card, which cards already include a user identification means, to allow user billing through the phone network operator.

In preferred embodiment the downloaded data is MP3 or other encoded audio data, but the system finds more general application for other data types. For example, download data can include software, and particularly games, share price information, current news information, transport timetable information, weather information and catalogue shopping information. The downloaded information may also include compressed video data. The storage capacity of the data storage means is adaptable to suit the type of data intended to be downloaded - for example, 32 megabytes is sufficient for CD-quality music, but for video it is preferable that the data storage means has a capacity of 128 megabytes or greater.

In another aspect, the invention provides a portable data carrier comprising an interface for reading and writing data from and to the carrier; non-volatile data memory, coupled to the interface, for storing data on the carrier; non-volatile payment data memory, coupled to the interface, for providing payment data to an external device.

These features allow the data carrier to store both payment data and content data thus providing the advantages outlined above. Depending upon the payment system used, the payment data memory may also store code for validating or confirming a payment to an external payment system. The payment data will normally be linked to card or card holder identification data for payment by the card holder. The non-volatile memory ensures that stored content and payment data is retained in the data carrier when the data carrier is not receiving power from an external source. Thus "non-volatile" encompasses, for example, low-power memory whose contents are retained by a battery back-up system. In one embodiment the payment data memory comprises EEPROM and the content data memory comprises Flash memory, but other types of content data memory, such as optical, for example, holographic, data memory can also be used. The

data carrier may also be integrated into other apparatus, such as a mobile communications device.

Preferably, the portable data carrier further comprises a program store storing code implementable by a processor; and a processor, coupled to the content data memory, the payment data memory, the interface and to the program store for implementing code in the program store, wherein the code comprises code to output payment data from the payment data memory to the interface and code to provide external access to the data memory.

Normally, the (content) data memory allows both write and read access for both storing and retrieving data, but in some embodiments the content data memory may be read only memory. In such embodiments, content may be pre-loaded onto the carrier and payment may then be made for permission to access the pre-loaded data.

Preferably, the data carrier also stores a record of access made to the content data and updates this in response to external access, preferably read access, made to the data memory. The carrier may also store content use rules pertaining to allowed use of stored data items. These use rules may be linked to payments made from the card to provide payment options such as access to buy content data outright; rental access to content data for a time period or for a specified number of access events; and/or rental/purchase, for example where rental use is provided together with an option to purchase content data at the reduced price after rental access has expired.

Thus where the data carrier stores, for example, music the purchase outright option may be equivalent to the purchase of a compact disc (CD), preferably with some form of content copy protection such as digital watermarking. In this example, the rental or subscription payment option may be a pay-per-play option, and with this option payment may either be before or after access to the stored data so that the carrier may operate in either a debit or credit payment mode.

The portability of the data carrier potentially allows it to be used to access content or, in the example, play music without the need to be linked to a communications system or to be on-line to the internet. By providing a use record memory on the data carrier, use of the stored data can be tracked whilst off-line and then any necessary payment can be made when the data carrier is next coupled to a communication system. This allows the data carrier to operate in a credit mode. In a debit mode, the additional storage of use rules facilitates the regulation of access to content data stored on the carrier without the need for further exchange of payment/use data with an external system to validate the use.

By combining digital rights management with content data storage using a single carrier the stored content data becomes mobile and can be accessed anywhere whilst retaining control over the stored data for the data content provider or data copyright owner. Preferably, the data carrier also stores access control data, such as a user ID and a password, as the stored data may be valuable. The access control data may be combined with access control to the payment data, which is typically by means of a PIN (Personal Identification Number) to simplify access to valued content stored on the carrier.

In one embodiment the stored content data is encrypted and a unique password or PIN and/or biometric data is required for decryption. The data carrier may be arranged so that the content is erased after a predetermined number of incorrect access attempts. Additionally or alternatively, a permanently stored flag may be set and/or a hardware modification (such as a fusible link) may be made to prevent the data carrier from functioning for further data storage/retrieval. Preferably, however, access to any stored value/payment data is nevertheless retained.

Supplementary data may also be stored on the carrier in association with stored content data. This supplementary data may comprise customer reward management data and/or advertising data. The supplementary data may comprise a pointer to an external data source from which data is downloaded either to the data carrier or to a data access

device or content player, so that advertising or other data can be displayed when reviewing or accessing the stored content.

Additional data security and/or a mechanism for rewarding operators at different levels in the data supply chain may be provided using a content synthesis function. The content synthesis function combines partial content information from two or more sources to provide content data items for storage and/or output. Thus, for example, a first percentage of a content data item could be provided by a content retailer whilst a remaining percentage could be provided by an on-line data supplier. This would provide an incentive for a user to register with a content retailer or distributor as well as with an on-line scheme owner and so could encourage the use of existing retailers and could provide a mechanism for paying commission to such retailers. The two portions of data combined to provide a content data item could comprise encryption data and a key but preferably comprise separate parts of a complete data item, for example, least significant bits and most significant bits or high frequencies and low frequencies (for audio). This arrangement also facilitates customer reward and loyalty management.

In one embodiment the data carrier further comprises memory for storing data for accessing a mobile communications network, for example to receive content data over the network. For such an embodiment, the data carrier may replace a SIM (Subscriber Identity Module) card in a mobile communications device, thus providing a single card for both network access and valued content retrieval and storage. Additionally or alternatively the card may also store the web address of a data supplier from whom data may be downloaded onto the carrier.

The data memory for storing content data may be optic, magnetic or semiconductor memory, but preferably comprises Flash memory. Preferably, the data memory has a large capacity for storing large data files such as compressed video data. Preferably, the data memory is partitioned for lock access, that is for read and/or write access to blocks of, for example, 1K, 4K, 16K or 64K databytes for faster data access, particularly where the stored content data will normally be accessed serially, as is normally the case with

audio and video data. Preferably the card is configured as an IC card or smart card and has a credit card-type format, although other formats such as the "memory stick" format may also be used. This provides a small and convenient portable format and facilitates removable interfacing with a variety of devices.

The invention also provides a related method of controlling access to data on a data carrier, the data carrier comprising non-volatile data memory and non-volatile parameter memory storing use status data and use rules, the method comprising receiving a data access request; reading the use status data and use rules from memory; and evaluating the use status data using the use rules to determine whether access to the stored data is permitted.

According to another aspect of the invention, there is provided a computer system for providing data to a data requester, the system comprising a communication interface; a data access data store for storing records of data items available from the system, each record comprising a data item description and a pointer to a data provider for the data item; a program store storing code implementable by a processor; a processor coupled to the communications interface, to the data access data store, and to the program store for implementing the stored code, the code comprising code to receive a request for a data item from the requester; code to receive from the communications interface payment data comprising data relating to payment for the requested data item; code responsive to the request and to the received payment data, to read data for the requested data item from a content provider; and code to transmit the read data to the requester over the communications interface.

The computer system is operated by a data supplier or data supply "scheme owner" for providing content data to the data carrier described above. The payment data received may either be data relating to an actual payment made to the data supplier, or it may be a record of a payment made to an e-payment system relating either to a payment to the data supplier, or to a payment to a third party. The data from the content provider, preferably without permanent (local) storage of the forwarded data. This improves data

security as the content provider retains control over a content data item and the data supplier, a copy of a data item, is unable to supply data for the item without the content provider's assistance. The computer system may provide temporary storage for a requested data item, for example, using a disk cache, but preferably the computer system does not store a complete data item, even temporarily.

Preferably, the computer system includes payment distribution information so that when payment is made for a data item, the payment can be distributed for reimbursing royalties and making other payments. Typically a large fraction of the payment for a data item will be transferred to a copyright owner or "content provider" for the item whilst smaller payments will go to the artist and/or publisher and/or retailer/distributor. Payment may be made directly by the computer system to the computer systems of other relevant parties using, for example, a signature-transporting type E-payment system. Alternatively, the computer system can issue appropriate instructions to a third party E-payment system for making the transfers. The computer system allows automatic distribution of payments either before, during or after content data download, or after content data access by a user. Instructions for distributing the payments may be issued substantially simultaneously, thereby avoiding long delays in the payment of some parties - for example, it can presently take a year or more for an artist generating content to be paid by conventional methods.

Preferably, the computer system also stores content data item access rule data, for downloading in association with a content data item. The rule data may be stored by a content provider but is preferably held by the computer system, and links a content identifier with an access rule, typically based upon a required payment value, as outlined above in the context of the data carrier. Normally, each content data item will have an associated access rule, but a single rule may apply to a large number of data items. The computer system also, preferably, stores requester reward data for customer reward/loyalty management. This data may again comprise one or more rules linking a payment value and/or content data item type to a specified reward, such as a number of air miles or retailer value points. The computer system preferably also keeps a record of

an identified user's or data's carriers content item downloads and payments for market research purposes.

The computer system, in one embodiment, also stores access control data, such as an access request identity and password which can be employed, for example, to create an extranet of system users, which again can be linked to stored access record data for marketing purposes. When further linked to content item type data, such an arrangement can be used to construct a club of users of content data items of a particular type, for example, country and western or rock and roll music. As described in connection with the portable data carrier, the computer system may also comprise content synthesis code for additional data security and for more secure management of payment distributions.

The invention also provides a related method of providing data to a data requester comprising receiving a request for a data item from the requester; receiving payment data from the requester relating to payment for the requested data; reading the requested data from a content provider responsive to the received payment data; and transmitting the read data to the requester.

According to a further aspect of the present invention, there is provided a data access terminal for retrieving data from a data supplier and providing the retrieved data to a data carrier, the terminal comprising a first interface for communicating with the data supplier; a data carrier interface for interfacing with the data carrier; a program store storing code implementable by a processor; and a processor, coupled to the first interface, the data carrier interface and to the program store for implementing the stored code, the code comprising: code to read payment data from the data carrier and to forward the payment data to a payment validation system; code to receive payment validation data from the payment validation system; code responsive to the payment validation data to retrieve data from the data supplier and to write the retrieved data into the data carrier.

This terminal can be used for retrieving data from the above described computer system and for downloading the retrieved data to the above described portable data carrier. As with the data supply computer system, it is preferable that there is no (local) storage of content item data forwarded from the data supplier to the data carrier. The data access terminal is not restricted to use with the above described status supplier and could, for example, retrieve data for downloading to the data carrier from a local data source, such as a CD (Compact Disc) or DVD (Digital Versatile Disc), or from a third party such as a cable TV company.

The terminal reads payment data from the data carrier and transmits this to a payment validation system for validating the data and authorising the payment. This may be part of the data supplier's computer system or it may be a separate system such as an e-payment system. Thus, the terminal operates with a data carrier storing payment (validation) data and, in some embodiments, additional payment validation code for validating payment to the payment validation system. Again, the terminal is preferably configured to provide a data item use rule to the carrier in conjunction with a data item. As before, the data item use rule will normally be dependent upon payment value information embodied in the payment data read from the data carrier. The terminal is preferably also configured for user input of access control data. This access control data may be forwarded to the data carrier for access permission verification and/or it may be passed to the data supplier computer system for a similar purpose. The terminal may be configured to warn a user of content access or data carrier function inhibition after a predetermined number of access requests have been refused. The terminal may also incorporate content synthesis code as described above.

The terminal may comprise code to output supplementary data when downloading data to the data carrier. Identity data on the data carrier can be used to retrieve the supplementary data, or a pointer to the supplementary data, from the data supplier computer system, or the supplementary data or a pointer thereto can be retrieved directly from the data carrier. Preferably, however, identification data on the card is used to retrieve characterising data such as card user preference data from the data supplier

computer system, and this characterising data is then used by the terminal to retrieve and output supplementary data to a terminal user. When the terminal is associated with a contact distributor or retailer, the supplementary data may be retrieved over a network associated with the retailer/distributor such as a local area network (LAN), wide area network (WAN) or extranet.

The invention also provides a method of providing data from a data supplier to a data carrier, the method comprising reading payment data from the data carrier; forwarding the payment data to a payment validation system; retrieving data from the data supplier; and writing the retrieved data into the data carrier.

The payment validation system may be part of the data supplier's computer systems or it may be a separate e-payment system. In one embodiment the method further comprises receiving payment validation data from the payment validation system; and transmitting at least a portion of the payment validation data to the data supplier. Alternatively the payment validation system may comprise a payment processor at the data supplier or at a destination retrieved from the data supplier. The payment processor may also provide payment distribution data for distributing a payment represented by the payment data.

In a further aspect, the invention provides a data access device for retrieving stored data from a data carrier, the device comprising a user interface; a data carrier interface; a program store storing code implementable by a processor; and a processor coupled to the user interface, to the data carrier interface and to the program store for implementing the stored code, the code comprising code to retrieve use status data indicating a use status of data stored on the carrier, and use rules data indicating permissible use of data stored on the carrier; code to evaluate the use status data using the use rules data to determine whether access is permitted to the stored data; and code to access the stored data when access is permitted.

The data access device uses the use status data and use rules to determine what access is permitted to data stored on the data carrier. As described above, the use rules will

normally be dependent upon payments made for data stored on the data carrier, but may also comprise access control employing a user identification and password. Since a single data carrier may have more than one user, the use status and use rules may be selected dependent upon a user identity. The data access device may also be configured to present supplementary data when presenting the content data, retrieved as described above, from the card, from a remote computer system or from some other source such as a cable TV network or off-air.

The invention also provides a related method of controlling access to data from a data carrier, comprising retrieving use status data from the data carrier indicating past use of the stored data; retrieving use rules from the data carrier; evaluating the use status data using the use rules to determine whether access to data stored on the carrier is permitted; and permitting access to the data on the data carrier dependent on the result of said evaluating.

According to a further aspect of the invention there is provided a data access system comprising a data supply computer system for forwarding data from a data provider to a data access terminal; a electronic payment system for confirming an electronic payment; a data access terminal for communicating with the data supply system to write data from the data supply system onto a data carrier; and a data carrier for storing data from the data supply system and payment data; wherein data is forwarded from the data provider to the data carrier on validation of payment data provided from the data carrier to the electronic payment system.

In a further aspect of the invention, there is provided a portable data carrier comprising an interface for sending and receiving data from and to the carrier; non-volatile data memory, coupled to the interface, for storing data on the carrier; and a digital rights management processor for controlling access to the stored data.

In a further aspect of the invention, there is provided a portable data carrier comprising an interface for sending and receiving data from and to the carrier; non-volatile data

memory, coupled to the interface, for storing data on the carrier; and an access control processor; wherein the data memory is partitioned as data blocks and the access control processor controls external access to the data blocks.

In a further aspect of the invention, there is provided a computer system for providing data to a data requester, the system comprising a communication interface; a data access data store for storing records of data items available from the system, each record comprising a data item description and a resource locator a data provider for the data item; a program store storing code implementable by a processor; a processor coupled to the communications interface, to the data access data store, and to the program store for implementing the stored code, the code comprising code to receive a request for a data item from the requester to receive from the communications interface payment data comprising data relating to payment for the requested data item; code, responsive to the request and to the received payment data to output the item data to the requester over the communication interface; wherein said data access data store further comprises payment distribution information indicating to whom payments should be made for a data item; and further comprising code to output payment data for a data item for making payments for the item when the item is supplied to a said requester.

In a further aspect of the invention, there is provided a computer system for providing data to a data requester, the system comprising a communication interface; a data access data store for storing records of data items available from the system, each record comprising a data item description and a printer location data identifying an electronic address for a provider for the data item; a program store storing code implementable by a processor; a processor coupled to the communications interface, to the data access data store, and to the program store for implementing the stored code, the code comprising code to receive a request for a data item from the requester to receive from the communications interface payment data comprising data relating to payment for the requested data item; code responsive to the request and to the received payment data to output the item data to the requester over the communication interface; wherein said data access data store further comprises data item access rule data for output to the

requester with a said data item; and further comprising code to select access rule data for output with a data item in response to said payment data.

In a yet further aspect of the invention, there is provided a method of providing data to a data requester comprising receiving a request for a data item from the requester; receiving payment data from the requester relating to payment for the requested data; transmitting the requested data to the requester; reading payment distribution information from a data store; and outputting payment data to a payment system for distributing the payment for the requested data.

In a still further aspect of the invention, there is provided a method of providing data to a data requester comprising receiving a request for a data item from the requester; receiving payment data from the requester relating to payment for the requested data; transmitting the requested data to the requester; and transmitting data access rule data to requester with the read data.

These and other aspects of the invention will now be further described, by way of example, only, with reference to the accompanying figures in which:-

Figure 1 shows a data access device a) from the top; b) from the front; and c) from the side;

Figure 2 shows, conceptually, a portable data carrier;

Figures 3a and b show exemplary data access terminals;

Figure 4a and b show, respectively, a logical signal path between elements of a conceptual data access system; and a physical representation of a conceptual data access system;

Figure 5 shows a content provision system;

Figure 6 shows a data supply computer system;

Figure 7 shows a variety of data access terminals;

Figure 8 shows a schematic diagram of components of a data access terminal;

Figure 9 shows a schematic diagram of components of a data carrier;

Figure 10 shows a schematic diagram of components of a data access device;

Figures 11a and 11b show a flow diagrams of a data carrier registration process;

Figures 12a-c and 12d-e show, respectively, a flow diagram of data access using a data access terminal; and a flow diagram of data supply using a data supply computer system; and

Figure 13 shows a flow diagram of data retrieval using a data access device.

Referring to Figure 1, this shows a data access device for playing MP3 audio (10) with operator controls (12) and LCD display (14). The outline of a smart card data storage device is shown at (16). The operator controls allow a user to select and play tracks, whilst track information and still or video images are provided on display (14). A slot (18) is provided in the front of the device to receive a smart card-type data storage means. This smart card occupies space (20) and interfaces with resilient contacts (24); it is held in the data retrieval device against the contacts, by resilient housing element (22).

Referring now to Figure 2, this shows a portable data carrier (30) suitable for use with the device of Figure 1. The data storage means is based on a standard smart card; it is plastic, about the size of a standard credit card, and has some flexibility. On the card

(30) are two sets of contacts, contacts (32) for interfacing with the payment validation means and contacts (34) for interfacing with the memory for storing downloaded data (although in other embodiments, a single set of contacts may be used for both). The surface of the card can be embellished with suitable graphics.

In one embodiment the smart card retains all its useable functionality as specified for standard Electronics Point of Sale Systems (EPOSS) and, if desired, the memory for storing the downloaded data can be electrically separate from this. However, it may be preferable to provide interaction between the standard smart card device and the data memory in order to accomplish the access control/decryption functions described above.

Referring now to Figure 3, an example of a data access terminal is shown at (40). This has a screen (42) and a slot (44) to receive the data carrier (30). Alternatively the data carrier may interface to the terminal via the data access device (10) and an interface (46) to the terminal (40). In Figure 3b a dedicated terminal (50) has a slot (52) to receive the data carrier, a display (54) and controls (56). Coins can be inserted into the terminal at (58) and notes at (60) to charge the data carrier with cash.

Referring now to Figure 4a, this illustrates conceptually the logical connections and data flow between data processing systems involved in payment validation, and data download to the carrier (30). A user connects the data carrier (30) to terminal (40) and logs on to a data web page of data supply service provider (60). Either terminal (40) or service provider (60) then communicates via data paths (62) with a payment validation authority (70) to check and authorise the user's or payer's payment. In the case of electronic cash the terminal (40) may immediately validate the payment information, updating the service provider and/or payment validation authority (70) at a later stage. The logical connection (64) between the terminal and the service provider is preferably made over the internet.

The service provider may provide a direct portal to data providers (80) or may collect information from data suppliers (80) and provide a "front end" to present data from the

suppliers to the terminal user. Alternatively data supply service provider (60) may regulate direct access between terminal (40) and data providers (80), as shown by links (66), by communicating with the terminal and the data providers to provide communication regulation information to, for example, instruct data suppliers about what information the user of terminal (40) should have access to.

In a preferred embodiment service provider (60) pays royalties at an agreed rate - for example, 10 pence per track or 10 pence per minute - to a computer system owned by a company or entity in the recording industry, such as a content provider or copyright owner, a content publisher or a content creator, and the user of terminal (40) effectively pays the service provider. Billing can also be regulated by bandwidth and/or data download time.

Preferably the service provider (60) monitors the user's access to the system and either stores or forwards to data providers (80), or downloads to the data carrier (30), usage information. In a preferred embodiment the service provider sends information via terminal (40) to data carrier (30) which can be used to determine incentives to be provided to users of the system.

Figure 4b shows a conceptual physical configuration of the system of Figure 4a in which a plurality of terminals (40), a plurality of service providers (60) and a plurality of data providers (80) all interact via the internet. The physical embodiment of the system is not critical and a skilled person will understand that the terminals, data processing systems and the like can all take a variety of forms.

Referring now to Figure 5, this shows a conceptual illustration of a content provision system 100. Content creators 104a, b generate or receive content data from artist terminals 102a-d and store content data in databases 106a, b. The content data stored in databases 106a, b may comprise audio data, such as music, video data, such as films or TV programs, text, such as literary works, software, such as games software, or other data. Content creators 104a, b are coupled to communications network 101 for

communicating created content data over the network. Also coupled to communications network 101 are content publishers 110a and 110b, each of which is coupled to an associated stored content database, 112a and 112b respectively. The content publishers make their stored content available for controlled access using communications network 101. In some instances, for example where the content data comprises computer games, the functions of content creator and content publisher may be provided by a single entity. Also although conceptually illustrated as blocks in Figure 5, the content creator and content publisher typically each comprise a client server computer network.

The communications network 101 is typically a private communications network, such as an extranet, with security controlled access to entities connected to the network. Physically the network may comprise an internet protocol network or it may comprise, or consist of, dedicated point-to-point links. Thus, for example, a content creator 104 may be directly linked to a content publisher 110 and/or to other entities shown in Figure 5 such as a content provider or content distributor.

The content provision system includes a plurality of content providers 108a-e, each coupled to the communications network 101. In the illustrated system, the content providers own copyright in stored content data accessible over communications network 101 and may, in practice, also perform a content publication function. Five content providers own the copyright in over 80% of all world-wide music sales. The content providers are coupled to stored content databases 106 and 112 via communications network 101, for supplying stored content data.

A gateway server 114 is also coupled to communications network 101 to link the communications network to other networks such as the internet and/or mobile communications networks. Gateway server 114 provides security and access control functions and firewalls. A second gateway, content distributor WAN gateway 116 is also shown attached to communications network 101. This provides similar security and firewall functions and coupled communications network 101 to distributor WAN (wide area network) 117. Gateway 116 has logical access to one or more of a content

creator, content publisher and content provider for accessing stored content data. Content distributor gateway 116 may be owned by a chain of record stores and provide content access terminals 118, coupled to WAN 117, in separate retail outlets. Content access terminals 118 have access, via gateway 116, to stored content accessible over communications network 101.

Referring now to Figure 6, this shows a data supply computer system 120. In this embodiment, three content access terminals 118a-c, e-payment systems 121a, b, and content access web server 124 are all coupled to internet 142. Data supply system 120 is coupled to the content provision system 100 illustrated in Figure 5. Where Communications network 101 of Figure 5 is an extranet, this extranet physically operates over internet 142; where communications network 101 does not partly operate via internet 142, a connection to internet 142 is established via gateway server 114 as shown in Figure 5. In this way content access terminals 118a-c are provided with controlled access to the stored content data of content provision system 100.

E-payment systems 121a and 121b are coupled to banks 122a, b and c, d respectively. These provide an e-payment system according to, for example, MONDEX, Proton, and/or Visa cash compliant standards. Preferably at least one of e-payment systems 121a, b operates a so-called "open purse" system in which the value is stored as a publicly verifiable digital signature issued by the e-payment system. In such a signature-transporting arrangement payment data may be validated using public keys and thus payment authentication need not be performed by the e-payment system but may instead be performed by, for example, a data access terminal or data supply system computer, using payment management code. The authenticated signatures, which in effect perform a similar role to cheques, are submitted to the relevant e-payment system after authentication for verification and reimbursement or transfer of monetary value. With such a system payments may be made anonymously and thus payer identification is not essential. Data carriers, such as data cards, may be issued with stored value or without value, in which latter case value (that is a publicly verifiable digital signature) may be written onto the card during an on-line transaction.

In alternative embodiments, a data carrier such as the smart flash card described below may be used to create value bearing digital signatures as is well-known to those familiar with e-money.

Content access web server 124 is also coupled to internet 142 for providing content access terminals 118a-c with access to content data. Content access web server 124 is typically owned by a content data supply "scheme owner" who acts as an intermediary between a content access terminal user and a content provider, forwarding content data provided (directly or indirectly) by a content provider to a content access terminal and thence to a stored content data carrier. Web server 124 is coupled to web server code storage 126 storing Java code for generating web pages for interpretation by web browsers on content access terminals 111a-c. The web pages provide the content download, value add, CRM (customer reward management) value cheque/spend and website link functions described below.

Web server 124 is coupled to payment processor 128, Digital Rights Management (DRM) processor 130, access control processor 132, and content distribution processor 134. Payment processor 128 includes payment management code storage 128a and is coupled to payment record data store 136. Access control processor 132 includes access control code storage 132a and is coupled to access control data store 138. DRM processor 130 includes DRM code storage 130a and is coupled to content access and DRM data store 140. Content distribution processor 134 includes CRM (customer reward management) and payment distribution management code storage 134a and is also coupled to content access and DRM data store 140. As shown in Figure 6, processors 128-134 are all in communication with one another.

Processors 128, 130, 132 and 134 may comprise separate application programs or a single computer program and may operate on a single physical computer, on which web server 124 may also be provided, or may operate on separate computers. Likewise data stores 136, 138 and 140 may comprise a single physical data store or may be distributed

over a plurality of physical devices and may even be at physically remote locations from processors 128-134 and coupled to these processors via internet 142.

Web server 124 communicates with processors 128-134 by means of a CGI (common gateway interface) script and the code associated with processors 128-134 may be written in any conventional computer language such as C, C++, or Perl. However, in other embodiments one or more of the processors may be coupled to web server 124 via internet 142 and owned and operated by a separate entity, such as a financial institution. In this case conventional secure web-based communications may be operated between web server 124 and the relevant processor. In particular, payment processor 128 may be operated by one of the e-payment system providers 128a, b.

Payment management code 128a issues and authenticates payment data and stores an audit record in payment record data store 136. Access control code 132a stores identification data (of a user or card) together with registration data provided by user when registering with the scheme owner. This data comprises a user password for accessing stored content and/or payment data; user characterising data, for example characterising user preferences, for marketing purposes; data indicating an e-payment system to use; and in some embodiments, further general user related data such as card level data for identifying the provision of "gold" level services to selected users. A copy of the password is stored with the content data on the portable data carrier, as described further below. Alternatively, one or both of the access control data store and portable data carrier may simply store data for verifying a user-entered password.

Content access and DRM data store 140 stores data related to content access and content use, but does not itself store content data items; these are instead provided via content provision system 100 described above. Data store 140 stores a plurality of records each comprising a data item identifier, a data item description, a data item type or genre, and location data comprising one or more pointers to a location or locations from where the data item can be downloaded. Associated with a data item is also a table of use rule data comprising a list of values (i.e. content data item prices) and corresponding levels

of permitted usage. Thus a value of £1 might permit ten plays of a music track, whilst the value of £10 might permit an unlimited number of plays of the track and copying of the track for personal use.

Also associated with a data item is a table of payment distribution data comprising a list of recipients and corresponding fractions of the data item value each is to receive. Typically, the main recipient will be the copyright owner of the data item and other recipients will be selected from the content creator, the artist or artists, the scheme owner, the content publisher, and the retailer/distributor. The payment distribution proportions may be dependent upon the payment value in which case a plurality of sets of payment distribution figures may be associated with each data item, each set of distribution figures corresponding to a payment value range. The payment data and distribution data is here termed DRM (Digital Rights Management) data.

Further associated with a data item is a table of CRM (Customer Reward Management) data, linked to the user rule data, comprising CRM rules to specify, for one or more data item use levels, a quantity of reward points and one or more recipients for the reward points (the recipients may include the card user and the retailer/distributor).

The CRM and payment distribution code 134a operates with content access and DRM data store 140 to inform a system user of the description and value of a data item, to access and download a data item from the content provider system to a content access terminal, to provide content use rules with the data item, and to provide instructions either to payment processor 128 or to E-payment system 121 to distribute payments for the data item to the recipients identified by the data store 140 and to distribute CRM reward points.

The access control data store 138 holds a secure key, such as a secret "public" key in a public key cryptography system, for the scheme owner to authenticate its identity to a content provider. This data is held securely with other sensitive data in the access control data store 138. As is described in more detail below, when data supply system

120 receives a request for a content data item from a content access terminal 118, it looks up a location from which the data item is available using content access and DRM data store 140 and then determines the identity of the corresponding content provider. This identity is either stored in content access and DRM data store 140 or, as there are relatively few content providers, it may be hard written in DRM code 130a. DRM code 130 then requests access control processor 132 to provide the secure scheme owner identifier from access control data store 138 to the relevant content provider and sets up a trusted connection between the content provider and content access web server 124 for downloading the data item to a content access terminal 118 and thence to a portable data carrier.

Referring now to Figure 7, this shows a variety of content access terminals for accessing data supply computer system 120 over internet 142. The terminals are provided with an interface to a portable data carrier or "smart Flash card" (SFC) as generally described with reference to Figure 2 and as described in more detail below. In most embodiments of the terminal the SFC interface allows the smart Flash card data carrier to be inserted into and removed from the terminal, but in some embodiments the data carrier may be integral with the terminal.

Referring now to the specific embodiments illustrated in Figure 7, a simple content access terminal may comprise a home personal computer 144 with SFC interface 144a. In another embodiment, a mobile communications device 152 is provided with a smart Flash card interface 152a and is coupled to internet 142 via radio tower 150, mobile communications system 148 and mobile communications internet gateway 146.

In another embodiment, a smart Flash card interface is provided to a so-called "set top box" (STB) 154. The set top box is, in effect, a receiver for television programmes received on video input 154b, which may comprise a satellite TV signal, a cable TV signal or an off-air TV signal. The video signal is provided from the set top box to television 156 or to some other home entertainment device such as a personal computer (not shown). In another embodiment content access terminals 166 and 168 each with

respective SFC interfaces 166a and 168a are coupled to a retailer local area network (LAN) 160 connected to internet 142 via retailer LAN server 158. DVD player 164 is also coupled to LAN 160. In a further embodiment a smart Flash card interface 170a is provided for a CD/DVD player 170.

In these latter three embodiments, content data for storage on the smart Flash card may be retrieved from broadcast video and/or a CD or DVD. In this case, the computer data supply system 120 illustrated in Figure 6 may be used to provide use rule data for the content data stored on the smart Flash card, and to pay for data downloaded onto the card; the content data may be captured before or after the data supply system 120 is accessed to enable use of the stored data, but in a preferred embodiment content data written to the card from a supplier other than the content data supply computer system is not accessible to a user until corresponding use rule data has been downloaded from computer system 120, which will normally be after receiving payment for the downloaded data.

Referring now to Figure 8, this shows a schematic diagram of one embodiment of a data access terminal 170. The terminal comprises a general purpose computer including an audio/visual interface 184, a keyboard 186 and a pointing device 188 for providing an interface to the user. The terminal has an internet interface 176, for example a modem, and optionally a LAN/WAN interface 174 for connecting the terminal to a retailer or distributor LAN or WAN. The terminal also has an optional video input 178 for receiving broadcast video data and a media input device 180, such as a CD or DVD drive. Further communications I/O ports 182 may also be provided. A portable data carrier or smart Flash card interface 190 is provided for interfacing to a smart Flash card. Optionally, a cash input and verification system 192, such as is conventionally used in an automatic teller machine (ATM) may also be incorporated within the content access terminal. The terminal has working memory 194 such as RAM and program memory 196 which can comprise any conventional storage device such as RAM, ROM or a disk drive. Program code in program memory 196 may also be stored on removable disk 198. A processor 200 loads and implements program code stored in program

memory 196. All the components of the terminal are linked by a data and communications bus 172.

More specifically, processor 200 loads and implements cash payment management code 200a for managing cash input data from cash input and verification system 192, for adding value to a smart Flash card. Processor 200 also implements a web browser 200b for accessing scheme owner web pages and data exchange interface 200c for exchanging data between a smart Flash card interface to the terminal and data supply system 120.

Processor 200 also implements off-line contents retrieval code 200d for retrieving data for storage on a smart Flash card from media input device 180 and/or video input 178 and/or LAN/WAN interface 174. The processor implements a content sampler 200e for outputting small extracts of content data items to a user via audio/visual interface 184. Such data item samples may be stored with the content description data in content access data store 140. The processor also implements a smart Flash card interface driver 200f, user interface code 200g and additional communication drivers 200h for driving LAN/WAN interface 174 and/or comms I/O ports 182.

Referring now to Figure 9, this shows a schematic diagram of components of a portable data carrier 202, in the embodiment shown a so-called "smart Flash card". In this context, "smart Flash card" refers to an IC card similar in size to a plastic payment card incorporating a processor and Flash data memory, preferably of large capacity. For further details on smart cards reference may be made to the ISO (International Standards Organisation) series of standards including ISO 7810, ISO 7811, ISO 7812, ISO 7813, ISO 7816, ISO 9992 and ISO 10102, which are hereby incorporated by reference.

Referring in more detail to Figure 9, a data and communications bus 204 links components of the card which include a processor 210, working memory 212, timing and control logic 208 and an external interface which may have contacts (ISO 7816) or be contactless (ISO 10536) for providing external access to a bus 204 for reading data from and writing data to the card 202. Also coupled to bus 204 are permanent program

memory 216, non-volatile data memory 218 and non-volatile (Flash) content data memory 214. Non-volatile data memory 218 may comprise EEPROM and permanent program memory 216 may comprise ROM, for example, mask-programmed ROM. All the components of Figure 9 are mounted on a single substrate, in a preferred embodiment bearing contacts for external interface 206.

Processor 200 loads and implements program code from permanent program memory 216. This code comprises operating system code for providing the card with a basic operating system for at least external communications, payment management code for supplying payment data from non-volatile data memory 218 to pay for downloaded content; DRM (Digital Rights Management) and security code including code to implement content data use rules and code for password controlled access to data and program functions; CRM code for implementing CRM-related rules; and content synthesis code for combining stored content data with additional data provided via external interface 206 for synthesising complete content item data.

Non-volatile data memory 218 stores data including card identity data, access control data, including password data for validating a user password, access record data for storing a record of access attempts and their outcomes, and content supply data such as scheme owner website addresses and retailer/distributor website addresses.

Data memory 218 further stores card value data comprising E-money such as publicly verifiable digital signatures, and payment data for storing a payment audit trail including payment amounts and data on to whom payments have been made. The memory 218 also stores RFM (Recency Frequency Monetary) data to provide a record of transactions for market research and customer reward purposes, and CRM data storing customer reward points. Data memory 218 also stores an index of content data items stored in Flash memory 214 and associated content use rules, as well as DRM and royalty data for maintaining an audit trail of use history for rights management tracking. Optionally, data memory 218 may also store supply chain data specifying a supply chain route through which data has been obtained from a content provider, which may be used for

rewarding supply chain intermediaries, for example on a commission or reward points basis.

Content data memory 214 preferably comprises at least 100 MB of data storage, partitioned as data blocks of a size selected to match the stored content type. For storing video data Flash memory 214 preferably comprises > 1 GB data storage and the data blocks into which the data memory is partitioned are larger.

Referring now to Figure 10, this shows a schematic diagram of a data access device 220, such as a portable audio/video player. The data access device 220 comprises a conventional dedicated computer system including a processor 238, permanent program memory 236, such as ROM, working memory 234, such as RAM, and timing and control logic 226 all coupled by a data and communications bus 222. Also coupled to the bus are an audio interface 228, a display 230 and user controls 232, for providing a user interface. A smart Flash card interface 224 is coupled to bus 222 for interfacing with a smart Flash card for retrieving and playing stored content data.

Permanent program memory 236 stores program code for implementation by processor 238; this code may also be provided on a data carrier such as a ROM chip or disk 240. Processor 238 implements an SFC interface 238a, a user interface 238b, a content player 238d for retrieving stored content data from a smart Flash card interfaced to the device and for outputting audio and/or video data derived from the retrieved content data (which may comprise compressed audio and/or video data) to a user of the device.

Processor 238 also implements use control 238c for controlling access to and use of contents stored on the smart Flash card by the content access device user. Use control routine 238c and/or DRM and security code in permanent memory 216 on the smart Flash card may also implement digital watermarking and other Secure Digital Music Initiative (SDMI) content protection code as specified in the SDMI portable device specification, part one, version 1.0 (see www.sdmi.org) which is hereby incorporated by reference.

Figures 11a and 11b show a flow diagram of a process for registering a data carrier or smart Flash card with a data supplier or scheme owner operating a data supply system as illustrated in Figure 6. A smart Flash card may be issued entirely blank, that is, with no prestored content or value, with prestored value but no prestored content, with prestored content but not prestored value (the content being provided free) or with both prestored value and prestored content. Thus, for example, a user may purchase a card with stored value but no stored content over the counter at a retailer. The process of Figures 11a and 11b illustrates the registration of a card with neither prestored content nor prestored value. As illustrated the registration process records user registration data in the access control data store 138 of Figure 6 and writes value data onto the blank card.

At step S10 a smart Flash card is inserted into a content access terminal smart Flash card interface. The scheme owner web page is then loaded onto the content access terminal and displayed to the user (step S11). User registration data is then entered into the content access terminal (step S12) and transmitted to the scheme owner (S13), the user registration data may include a user identity, a preferred e-payment system to use and, optionally, a content access PIN or password, and a service level (for example bronze, silver or gold). The optional password may be a password required by the e-payment system for validation of a payment by the user with the card or it may be a password to protect unauthorised access to content on a smart Flash card to protect stored data in the event, for example, of the card being stolen. A single password may serve both these functions. The content access terminal web browser is configured so that all sensitive data passing between the terminal and the scheme owner is securely transmitted, for example by using a conventional encryption system such as PKI (Public Key Infrastructure).

At step S14 a payment request is received from the scheme owner at the content access terminal and displayed to the user. At step S15 the user enters payment data into the content access terminal and this payment data is transmitted to the scheme owner, for adding value to the card. This may, for example, be a credit card transaction as is

conventionally used for purchase over the internet. Card value data and a card value access code is then received by the content access terminal from the scheme owner at step S16. The card value corresponds to the payment made by the user and the value access code may be a password entered by the user at step S12 or may comprise a password for PIN created by payment processor 128 or e-payment system 121 as illustrated in Figure 6. In a preferred embodiment, the user pays the scheme owner and the scheme owner then directly provides digital signature data representing value to the content access terminal for writing onto the smart Flash card.

At step S17, card registration data is received from the scheme owner by the content access terminal and written onto the smart Flash card. This card registration data comprises user identity data, access control data, payment system specifying data, scheme owner access data, such as a scheme owner web page address and other dial-up information. At this stage other data may be entered by the user and written onto the card including, for example, user preference data, retail outlet and CRM data (alternatively user preference data may be captured at step S12). At step S18 the card value data and card value access code received at step S16 is written onto the card and output to the user visually and, optionally, as a printed record. The card is then available for use, at step S19.

Figure 11b shows the corresponding registration steps performed by the scheme owner's data supply system 120. At step S20, a request for a smart card registration web page is received from a content access device and, at step S21, transmitted to the device. User registration data is then received, at step S22, from the content access terminal and stored in content access control data store 138. The scheme owner's computer system then transmits, at step S23, a payment request to the content access terminal and receives, at step S24, payment data in reply, this payment is then authenticated, at step S25, with an E-payment system such as payment system 121 a or b illustrated in Figure 6, and after verification the payment processor 128 of the computer system transmits, at step S26, value data and a value access code to the content access terminal, for writing onto the smart Flash card. The payment processor then updates the payment record data

store 136 with data relating to the transaction (step S27) and, at step S28, retrieves card registration data previously written into the access control data store and transmits this registration data to the content access terminal. At step S29 the transaction is then complete.

Referring now to Figures 12a to c, these illustrate a flow chart for downloading data to a smart Flash card using a data access terminal. At step S30 the smart Flash card is inserted into the content access terminal and the user then enters, at step S31, their password for gaining access to the functionality of the smart Flash card. At step S32, the content access terminal transmits the password to the smart card for verification and the terminal checks, at step S33, whether access is permitted. If access is not permitted a warning is displayed by the terminal, at step S34, and an access denied count is implemented. A threshold count is then read from the card together with a count of the total number of times access to the card has been denied (step S35). At step S36 the terminal checks whether the total number of denied accesses is within three of the card threshold, and if it is not, returns to step S31 whilst if it is, it proceeds to step S37 where the terminal displays a warning that a further denied access is likely to result in erasure of content stored on the card. At step S38 the terminal then checks whether its count of denied accesses is greater than its threshold value, returning to step S31 if not, and displaying an access refused message at step S39 if the total number of permitted accesses has been exceeded. The system then waits at step S39 for removal of the smart Flash card from the content access terminal.

If access is permitted at step S33, the terminal loads outline CRM data from the card (step S40) and loads retail data, such as targeted advertising, from the retailer LAN/WAN (step S41). At step S42, the terminal then displays a menu of options, retail data such as advertising or CRM-related data and outline CRM data, such as a total number of reward points earned, on the content access terminal. Many options include download content (from a scheme owner), add monetary value (to the card), check/spend CRM value stored on the card, follow website links, and exit. At step S43, the user inputs a menu option which, in the illustrated flow chart, is the download

option. The system thus passes to step S44 and loads the scheme owner's content access web page onto the content access terminal and displays this to the user.

At step S45, the user enters a content search request, which is transmitted to the scheme owner content distributor processor 134. Content search results are received back from the content distribution processor, including a content identifier, a brief description, and content cost data for at least one payment option, and these results are displayed on the user on the content access terminal. The user then selects one or more content items at step S47 and the selection is transmitted to the content distribution processor 134 where further content cost data and purchase option data is retrieved from data store 140. At step S48, this content cost and purchase data (including use rule data) is received from the scheme owner and displayed to the terminal user. The user then selects, at step S49, a purchase option and confirms a purchase request or, alternatively, selects "exit" to return to the menu display of step S42. After one or more content items have been selected, together with a purchase option, hard value and CRM data is read from the smart Flash card at step S50 and at step S51 a check is made to determine whether the monetary and/or CRM (reward points) value stored on the smart Flash card is sufficient to purchase the selected purchase data items. If the card value is insufficient, a warning is displayed at step S52 and the system returns to the menu display at step S42. If the card value is sufficient, at step S53 the content access terminal transmits a payment request to the smart Flash card.

Payment for the data item or items requested may either be made directly to the scheme owner or may be made to an e-payment system such as e-payment systems 121a and 121b of Figure 6, with these systems then forwarding payment confirmation data to the scheme owner computer system. Alternatively, the content access terminal may transmit data to the card to set up a transaction directly with a content provider who, being the copyright owner, would normally receive the majority of the payment.

At step S54, payment data for making a payment to the scheme owner is received from the smart Flash card by the content access terminal and forwarded to an e-payment

system such as E-payment system 121 in Figure 6. Payment record data, validating payment by the card to the scheme owner is then received back from the e-payment system at step S55 by the content access terminal and forwarded to the card for updating payment data on the card. In alternative embodiments, payment data from the card may be provided directly to the scheme owner's data supply computer for authentication and, optionally, further validation with an e-payment system by the scheme owner's computer.

Distribution of the payment received by the scheme owner from the card is performed by the scheme owner's computer system, as described elsewhere. Such payment distribution will normally provide a small percentage of the total payment to a "owner" or operator of the content access terminal, such as a retailer, distributor, or in other embodiments, mobile communications network operator or cable TV network operator.

In the presently described embodiment payment record data received in step S55 is transmitted to the scheme owner to confirm payment by the card and thus it is the content access terminal, in the described embodiment, which authenticates a payment before confirming that the payment has been made to the scheme owner.

In step S56, together with the payment record data, purchase request and card registration data is transmitted to the scheme owner to identify one or more content data items for purchase and to identify the purchaser. Then, at step S57, the content access terminal sets up a transaction between the scheme owner data supply computer and the smart Flash card for download of the identified content items requested from the data supplier to the smart Flash card. The download is preferably arranged so that there is no permanent storage of downloaded data on the content access terminal (although temporary storage in a disk cache may be permissible), and there is further preferably no temporary storage on the content access terminal of complete data for a content data item. This provides data security and reassurance to the content providers.

In the same way as with card registration described with regard to Figure 11, a secure and trusted link is set up between the content access terminal and/or the smart Flash card and the data supply computer in a conventional manner as is well known to those skilled in the art (for example, using public key data encryption). The data transaction may be set up directly between the smart Flash card and the data supply computer, in which case the content access terminal has no access to unencrypted content data, or it may be set up between the content access terminal and the data supply computer, in which case unencrypted data is written by the content access terminal to the smart Flash card. Standard transmission protocols are used to ensure complete transmission of a content-data item, for example by re-transmitting blocks of data which are not correctly received.

Also at step S57, one or more content access rules is received from the scheme owner data supply computer and written to the smart Flash card so that each content data item has an associated use rule to specify under what conditions a user of the smart Flash card is allowed access to the content data item.

At step S58 the content access terminal receives CRM data from the content distribution processor 134 of the scheme owner, for example specifying a number of reward points earned by downloading the selected content items. This CRM data will normally be written to the smart Flash card (step S59), but may additionally or alternatively be stored in the content access terminal or in a data store of the content access terminal owner so that the reward points are held by the distributor/retailer/cable TV operator. Finally, also at step S59, a complete record of details of the transactions between the smart Flash card and the content access terminal, the smart Flash card and the scheme owner, the smart Flash card and the e-payment system, and the content access terminal and the e-payment system and/or data supply computer is recorded on the smart Flash card to provide an audit trail. The system then returns to the menu display at step S42.

The add monetary value menu option provided by the menu operates in a similar manner to that described with regard to steps S15 and S16 of Figure 11a and steps S24

to S27 of Figure 11b. In embodiments of the system in which the smart Flash card operates either in a debit (pre-pay) or credit mode, operating mode data may be loaded from the card together with outlying CRM data at step S40. If the card is operating in a credit mode then, at step S41, the content access terminal reads content use data records from the card and proceeds correspondingly to steps S47 and S48 to determine the value of the content accessed and then proceeds according to steps S15 and S16 of Figure 11a and steps S24 to S27 of Figure 11b to retrieve payment for the accessed content from the card owner. Where enhanced access control features are provided, access control data read from the smart Flash card or entered into the content access terminal at step S31 is used, in step S44, to access the scheme owner content access webpage and, in some embodiments, to set up a secure connection between the content access terminal and scheme owner data supply computer at step S44.

Referring now to Figures 12d and 12e, these show steps in a process implemented on the scheme owner's data supply computer, for providing content data to a content access terminal and thence to a data carrier such as a smart Flash card. At step S60 the scheme owner's content access web page is requested by a content access terminal and transmitted to the requesting terminal. A search request for searching for a content data item is received, at step S61, from the content access terminal and at step S62 content distribution processor 134 of the content supply system searches content access and DRM data store 140 and transmits the search results to the content access terminal. The search results will normally comprise a content item identifier, a content item description, optionally a content item sample, and at least one content item price, for example, for a default payment option. The search results may comprise a set of content data items, either selected by type or artist or comprising some predetermined selection in a similar manner to a compilation of tracks on a CD.

At step S63 content item selection data identifying one or more content items is retrieved from the content access terminal and at step S64 content item purchase data for the selected content items is retrieved from content access and DRM data store 140. This purchase data will normally include, for each selected content item, one or more

prices and purchase options. Purchase option data may simply comprise one of a set of standard options, for example, "1" to purchase outright, "2" to rent for a period of time, "3" to rent for a number of plays, and "4" to rent with a final purchase option. The purchase option data may also indicate when a content item is available free.

At step S65 the content purchase data is transmitted to the content access terminal, and at step S66 payment record data, indicating a payment made from the smart Flash card to the scheme owner, purchase request data, card registration data and, optionally, access control data is received from the content access terminal. The payment record data confirms a payment for the requested data items, the purchase request data specifies the payment option selected for the selected content items, and the card registration data provides data for keeping records of the transaction and providing reward points; the access control data may be required for additional data security. At step S67 the payment record data, in the described embodiment of the system, is validated with an e-payment system such as E-payment system 121 of Figure 6. As illustrated in the flow chart, the data supply system computer checks with the e-payment system that a payment has in fact been made to the scheme owner. In other embodiments of the system, payment may be made directly to the scheme owner and either concurrently with the content access and download process, or at some later stage, payment data received from the smart Flash card may be verified with the e-payment system for reimbursement of the scheme owner.

At step S68, payment distribution data is read from the content access data store 140. This data will indicate how payment made by the card for the data is to be distributed among recipients. In one embodiment, recipients' payment fractions are specified in general terms in the content access data store, for example, copyright owner 0.90, scheme owner 0.01, retailer/distributor 0.02, publisher 0.02, creator 0.05. Identification of who is the relevant copyright owner is stored in the data store together with the content item identifier, but may be selected from more than one possible content providers for the data item, and identification of who is the relevant retailer/distributor may be determined from, for example, content access identity information received from

the content access terminal when the scheme owner content access web page is accessed at step S60. At step S69, payments are then distributed in accordance with the payment distribution data, either by direct distribution of value-bearing digital signatures to the relevant parties, or by issuing a payment distribution instruction to e-payment system 121. Preferably the data supply system stores records of individual card payments and, at intervals, combines the payment distribution data for a plurality of individual records to output payment data for distributing the total payment received by the data supply system from a batch of individual payments.

At step S70, content access rules for the purchased level of service are read from the content access data store. These rules could, for example, specify that only a predetermined number of accesses to the content are permitted, for example 10 plays. Alternatively, the rules could provide access for, say, one month from the download date. Other rules may provide unlimited plays but only on specified players, for example, set top boxes owned by a particular cable TV network (as determined by content access device identification data provided to a smart Flash card from a content access device). A content provider identification for the requested content data is also read from the content access data store at step S70 together with CRM data for issuing reward points.

At step S71, content access rules for the requested content data items are retrieved from data store 140 and transmitted to the content access terminal. Then, at step S72, DRM processor 130 of the data supply system transmits a transaction request and authentication data to the content provider identified in step S70. This request identifies the scheme owner data supply system to the content provider in a secure manner, either by means of physical security, such as a dedicated connection from the scheme owner data supply system to the content provider, or by means of an electronically secure connection such as an encryption connection. Then, at step S73, the content access web server 124 receives protected content from the content provider, comprising the data items requested by the content access terminal, and transmits this protected content to the content access terminal. The content is preferably protected by data encryption but

may be protected in other ways, for example, by digital watermarking or simply by the large number of other transactions taking place at any one time over the internet. The data supply system computer, at this point, essentially acts as a transparent data forwarder, forwarding data from the content provider to the content access terminal, which itself is preferably effectively transparent, using data exchange interface 200c to transmit the protected content data directly to the smart Flash card. As described with regard to Figure 12d, the content download protocol includes error protection and transmission retry protocols to ensure substantially error free data transmission.

Once content has been downloaded to the content access terminal (and, hence, to the smart Flash card) at step S74 a record of the purchase data and content accessed is written to payment record data store 136, to provide an audit trail. Then, at step S75, updated CRM data is written to the content access data store 140, using rules stored in the content access data store, in conjunction with a record of the downloaded data items, to calculate the CRM data (i.e. reward points). The updated CRM data is then also transmitted to the content access terminal, where it can be forwarded to the smart Flash card. Then, at step S76, the process ends.

Referring now to Figure 13, this shows a flow chart for user access of stored data on a smart Flash card using a data access device such as the MP3 player of Figure 1. At step S77 the smart Flash card is inserted into the player and, at step S78, the user enters a password into the player, which is transmitted to the smart Flash card for validation (this step is optional). If access to stored data on the card is permitted, the process proceeds to step S79 where an index of content data items stored on the card is loaded from the card and displayed together with a menu. The menu provides options including access content, check value (stored on the card), check CRM data (such as reward points) stored on the card, and play options (such as no video, repeat play, random play, and the like). If the user wishes to access content data items stored on the smart Flash card, a user selection of such items is entered into the player at step S80, for example using cursor keys or a pointer; additionally or alternatively a default play option may be provided to, for example, play the most recently downloaded data.

At step S81 content use status data for the selected content items is loaded from the smart Flash card together with associated content use rules. Then, at step S82, the use rules and present use status for each selected content item are compared and the result is displayed together with a content play menu. The content play menu may comprise a simple list of the selected content items with items not available for access highlighted in, for example, red. Alternatively, more detailed content access permission data may be displayed such as the purchased contents use for a content data item, the actual use of the data item made so far, and the available remaining use. Then, at step S83, the layer determines whether content use is permitted. If use is not permitted, the process returns to step S79 to re-display the menu; if content use is permitted the system proceeds to step S84.

At step S84 the selected content data items whose use is permitted are retrieved sequentially from the card, decoded as necessary, and the decoded audio and/or video data is made available to the user, for example, by providing audio output at a headphone socket on the player and displaying video output on the player display. Preferably, the player also retrieves supplementary data stored in association with a content data item, such as advertising data, or for a web-enabled player, hot links to web sites for sale of goods or services, particularly those related to the accessed content data item or those identified to appeal to users accessing the data item (such as pop group merchandising or Harley Davidson (trade mark) motor bikes for rock music/video).

Preferably, the player is provided with "pause" and "continue" functions and corresponding user controls. When "pause" is selected the process passes to step S85 and writes a record to the smart Flash card comprising data specifying how much use has been made of the accessed content data item. In the case of music or video data, this may comprise start and end time markers or simply a play duration time (the start time being predetermined, for example at the start of the data item). In the case of a game the partial use data may comprise an elapsed play time or a number of lives left. In the case of a data item providing a service such as access to stock and share prices, or weather

information, or a share dealing service, the partial use information may comprise a status record indicating the status of an interrupted transaction. When the "continue" function is selected on the player the process returns to step S84.

To allow for the smart Flash card being removed from the player between pause and continue events, a check may be made at step S78, by reading a partial use status data from the card, to determine whether a content data item was left in a pause state when the card was last used. If such a paused state is determined to exist for a content data item, the process may then jump directly to step S85 to allow a user to resume or continue with the content data item and proceed directly to step S84.

Once play is complete the process moves to step S85 where updated content use data is written to the smart Flash card. This updated use data provides a record of the use of a content made in step S84. This record can then be used in steps S81 to S83 to determine, on a subsequent occasion, whether further use of the content data item is permitted. Finally, at step S86, customer reward management reward rules are loaded from the smart Flash card together with CRM data stored on the card. The CRM data is then updated, using the CRM reward rules, to reflect the use of content data items made in step S84 and the updated data is written back to the smart Flash card.

In one embodiment the CRM reward rules are determined by the content access terminal owner (retailer/distributor/cable or mobile network operator) and are written onto the card when registering the card. The updated CRM data may then be accessed by a content access terminal for spending or other use when the smart Flash card is next inserted into a content access terminal. Once the CRM data has been updated, the process returns to step S79 to display the content index and menu.

The specific embodiments of the invention described above use communication over the internet and web-based technology but this is not essential, and the invention may be implemented using any electronic communications network, such as a wide area network, local area network, wireless network, or conventional land line network.

Likewise, the invention is applicable to the Internet, intranets, extranets, and other internet protocol networks.

The skilled person will understand that many variants to the system are possible and the invention is not limited to the described embodiments but encompasses modifications which lie within the spirit and scope of the present invention.

Further aspects of the invention are set out in the following clauses:

1. A mobile data retrieval device comprising:
 - a removable data storage means;
 - data access means, to access downloaded data on the data storage means;
 - storage interface means adapted to couple the data storage and data access means; and
 - data output means to provide the downloaded data, in a useful form, to a user of the device;wherein the data storage means further comprises payment validation means to validate payment for the downloaded data.
2. A mobile data retrieval device as in clause 1 wherein the data storage means receives power from the retrieval device when connected to the device and retains storage by the downloaded data when unpowered.
3. A mobile data retrieval device as in clause 1 or 2 wherein the data storage means comprises external data interface means to receive data downloaded from an external source onto the card for storage and wherein the payment validation means comprises means to validate payment to the external source.
4. A mobile data retrieval device according to any preceding clause wherein the payment validation means comprises memory means to store transaction value information on a cash value of transactions validatable by the data storage means.
5. A mobile data retrieval device according to any preceding clause wherein the payment validation means comprises memory means to store information to identify a payer for the downloaded data.

6. A mobile data retrieval device according to any preceding clause wherein one of the data storage means and the retrieval device further comprises data description means to at least partially decrypt downloaded data.

7. A mobile data retrieval device according to any preceding clause wherein one of the data storage means and the retrieval device comprises access control means to prevent unauthorised access to the downloaded data.

8. A mobile data retrieval device according to clause 7 wherein the access control means is responsive to the payment validation means.

9. A mobile data retrieval device according to any one of clauses 3 to 8 wherein the payment validation means comprises a payment validation means interface operable simultaneously with the external data interface means.

10. A mobile data retrieval device according to any preceding clause wherein the data storage means comprises an electronic memory card or smart card.

11. A mobile data retrieval device according to clause 10 having a housing with a slot therein to receive the data storage means.

12. A mobile data retrieval device according to clause 11 further comprising local storage means and means to copy data from the data storage means into the local storage means.

13. A mobile data retrieval device according to clause 11 or 12 wherein the retrieval device is portable and, in two directions, is not substantially larger than the data storage means.

14. A mobile data retrieval device according to any preceding clause wherein the storage interface means is adapted for repeated removal and reconnection of the data storage means to the retrieval device.
15. A mobile data retrieval device according to any preceding clause further comprising display means to display information derived from the downloaded data to the user.
16. A mobile data retrieval device according to any preceding clause further comprising audio output means to provide an audio output corresponding to the downloaded data to the user.
17. A mobile data retrieval device according to any preceding clause comprising a first set of contacts for the storage interface means and a second set of contacts for interfacing to the payment validation means.
18. A data providing system comprising a mobile data retrieval device as in any preceding clause, and
a data access terminal to interface with the data storage means to download data and to co-operate with the payment validation means to validate payment for the downloaded data.
19. A data providing system as in clause 18 wherein the data access terminal is couplable to the internet and co-operates with the payment validation means to validate payment with a payment validation authority and is operable to download data to the data storage means from a data supplier on the internet.
20. A data providing system as in clause 19 wherein the data access terminal operates through a data access service provider, the data access service provider being configured to communicate with the payment validation authority and to control access of data access terminal to data from the data supplier.

21. A data storage means for use with the device or system of any preceding clause.
22. A data storage means comprising an external data interface means to receive data downloaded from an external source onto the card for storage; and payment validation means comprising means to validate payment to the external source, and/or to a payment validation authority.
23. A data storage means as in clause 22 further comprising data decryption means to at least partially decrypt the downloaded data.
24. A data storage means as in clause 22 or 23 further comprising access control means to prevent unauthorised access to the downloaded data.
25. A data storage means as in clause 24 wherein the access control means is responsive to the payment validation means.
26. A data storage means according to any one of clauses 22 to 25 wherein the payment validation means comprises a payment validation means interface operable simultaneously with the external data interface means.
27. A data storage means according to any one of clauses 22 to 26 wherein the data storage means comprises an electronic memory card or smart card.

**This Page is Inserted by IFW Indexing and Scanning
Operations and is not part of the Official Record**

BEST AVAILABLE IMAGES

Defective images within this document are accurate representations of the original documents submitted by the applicant.

Defects in the images include but are not limited to the items checked:

- BLACK BORDERS**
- IMAGE CUT OFF AT TOP, BOTTOM OR SIDES**
- FADED TEXT OR DRAWING**
- BLURRED OR ILLEGIBLE TEXT OR DRAWING**
- SKEWED/SLANTED IMAGES**
- COLOR OR BLACK AND WHITE PHOTOGRAPHS**
- GRAY SCALE DOCUMENTS**
- LINES OR MARKS ON ORIGINAL DOCUMENT**
- REFERENCE(S) OR EXHIBIT(S) SUBMITTED ARE POOR QUALITY**
- OTHER:** _____

IMAGES ARE BEST AVAILABLE COPY.

As rescanning these documents will not correct the image problems checked, please do not report these problems to the IFW Image Problem Mailbox.

CLAIMS:

1. A method of providing portable data comprising:
 - providing a portable data storage device comprising downloaded data storage means and payment validation means;
 - providing a terminal for internet access;
 - coupling the portable data storage device to the terminal;
 - reading payment information from the payment validation means using the terminal;
 - validating the payment information; and
 - downloading data into the portable storage device from a data supplier.
2. A method as claimed in claim 1 further comprising writing updated payment information into the payment validation means.
3. A method as claimed in claim 1 or 2 further comprising communicating a result of the payment information validating to the data supplier.
4. A method as claimed in any one of claims 1 to 3 further comprising controlling access by the terminal to data from the data supplier using a control data processing system coupled to the internet.
5. A method as claimed in claim 4 wherein the control data processing system performs said validating of the payment information.
6. A method as claimed according to any one of claims 1 to 5 wherein said coupling is performed by a mobile data retrieval device comprising:
 - a removable data storage means;
 - data access means, to access downloaded data on the data storage means;
 - storage interface means adapted to couple the data storage and data access means; and

data output means to output data derived from the downloaded data, to a user of the device.

7. A method as claimed in claims 1 to 6 further comprising writing into the data storage device data relating to past use made of the downloaded data including data identifying downloaded data items; and/or data identifying data suppliers used; and/or data characterising a user spending pattern.
8. A method as claimed in claims 1 to 7 wherein said portable data storage device comprises an electronic memory card or smart card.
9. A method as claimed in any one of claims 1 to 8 wherein the downloaded data comprises compressed audio and/or video data.
10. A portable data carrier comprising:
 - an interface for reading and writing data from and to the carrier;
 - non-volatile data memory, coupled to the interface, for storing data on the carrier;
 - non-volatile payment data memory, coupled to the interface, for providing payment data to an external device.
11. A portable data carrier as claimed in claim 10, further comprising a program store storing code implementable by a processor; and
 - a processor, coupled to the content data memory, the payment data memory, the interface and to the program store for implementing code in the program store,
 - wherein the code comprises code to output payment data from the payment data memory to the interface and code to provide external access to the data memory.
12. A portable data carrier as claimed in claim 11, further comprising non-volatile use record memory, coupled to the processor, for storing a record of access made to the

data memory and code to update the use record memory in response to external access made to the data memory.

13. A portable data carrier as claimed in claim 12, further comprising non-volatile use rule memory, coupled to the processor for storing data use rules, and wherein the code further comprises code for storing at least one data item in the data memory and at least one corresponding use rule in the use rule memory and code to provide external access to the data item in accordance with the use rule.

14. A portable data carrier as claimed in claim 11, 12 or 13, further comprising a non-volatile access control memory coupled to the processor, for storing access control data and wherein said code to provide external access to the data memory includes code to receive access request data from the interface, code to determine access permission using the stored access control data and code to provide external access to the data memory in response to the result of the determination.

15. A portable data carrier as claimed in claim 14, further comprising non-volatile access record data memory, coupled to the processor, for storing a record of requests for external access to the data memory and wherein said code further comprises code to compare said access record data and said access request data and to erase stored content data in response to a result of said comparison.

16. A portable data carrier as claimed in any one of claims 11 to 15, configured for storing supplementary data in said data memory and further comprising code to output the supplementary data from the interface in addition to the stored data, in response to an external request to read the data memory.

17. A portable data carrier as claimed in any one of claims 11 to 16 further comprising data synthesis code to receive a first portion of data from the interface and to combine the first portion with a second portion of data stored in the data memory and to store the result in the data memory.

18. A portable data carrier as claimed in any one of claims 10 to 17, further comprising non-volatile communications parameter memory for storing data for accessing a communications network to receive data from the communications network for storage in the data memory.

19. A portable data carrier as claimed in any one of claims 10 to 18, wherein the data memory is partitioned for access on a block-by-block basis, each block comprising a plurality of data bytes read or written as a set.

20. A portable data carrier as claimed in any one of claims 10 to 19 wherein said data memory has a capacity of greater than 1 MByte, more preferably > 100 MBytes, and most preferably > 1 GByte.

21. A portable data carrier as claimed in any one of claims 10 to 20 substantially configured as an IC card or smart card.

22. A method of controlling access to data on a data carrier, the data carrier comprising non-volatile data memory and non-volatile parameter memory storing use status data and use rules, the method comprising:
receiving a data access request;
reading the use status data and use rules from memory; and
evaluating the use status data using the use rules to determine whether access to the stored data is permitted.

23. A method as claimed in claim 22 wherein said parameter memory further stores payment data and further comprising selecting a said use rule dependent upon said payment data.

24. A computer system for providing data to a data requester, the system comprising:

a communication interface;
a data access data store for storing records of data items available from the system, each record comprising a data item description and a pointer to a data provider for the data item;
a program store storing code implementable by a processor;
a processor coupled to the communications interface, to the data access data store, and to the program store for implementing the stored code, the code comprising:
code to receive a request for a data item from the requester;
code to receive from the communications interface payment data comprising data relating to payment for the requested data item;
code responsive to the request and to the received payment data, to read data for the requested data item from a content provider; and
code to transmit the read data to the requester over the communications interface.

25. A computer system as claimed in claim 24, wherein said data access data store further comprises payment distribution information indicating to whom payments should be made for a data item; and further comprising code to output payment data for a data item for making payments for the item when the item is supplied to a said requester.

26. A computer system as claimed in claim 24 or 25, wherein said data access data store further comprises data item access rule data for output to the requester with said data item.

27. A computer system as claimed in claim 26, further comprising code to select access rule data for output with a data item in response to said payment data.

28. A computer system as claimed in claim 27, wherein said data access data store further comprises requester reward data associated with a said data item, and said code further comprises code to update said reward data in response to said payment data.

29. A computer system as claimed in any one of claims 24 to 28, further comprising an access control data store coupled to said processor for storing access control data comprising a requester identifier, corresponding requester system access data and payment system data for identifying a payment system for use by the requester.

30. A computer system as claimed in any one of claims 24 to 29, further comprising content synthesis code to generate substantially complete item data from partial item data provided from two or more sources.

31. A method of providing data to a data requester comprising:
receiving a request for a data item from the requester;
receiving payment data from the requester relating to payment for the requested data;
reading the requested data from a content provider responsive to the received payment data; and
transmitting the read data to the requester.

32. A method of providing data to a data requester as claimed in claim 31 further comprising:
reading payment distribution information from a data store; and
outputting payment data to a payment system for distributing the payment for the requested data.

33. A method of providing data to a data requester as claimed in claim 31 or 32 further comprising:
transmitting data access rule data to requester with the read data.

34. A method of providing data to a data requester as claimed in claim 33 further comprising:
selecting said access rule data dependent upon said payment data.

35. A data access terminal for retrieving data from a data supplier and providing the retrieved data to a data carrier, the terminal comprising:
- a first interface for communicating with the data supplier;
 - a data carrier interface for interfacing with the data carrier;
 - a program store storing code implementable by a processor; and
 - a processor, coupled to the first interface, the data carrier interface and to the program store for implementing the stored code, the code comprising:
 - code to read payment data from the data carrier and to forward the payment data to a payment validation system;
 - code to receive payment validation data from the payment validation system;
 - code responsive to the payment validation data to retrieve data from the data supplier and to write the retrieved data into the data carrier.
36. A data access terminal as claimed in claim 35 further comprising code to transmit at least a portion of the payment validation data to the data supplier or to a destination received from the data supplier.
37. A data access terminal as claimed in claim 35 or 36 further comprising code to retrieve from the data supplier and output to a user stored data identifier data and associated value data and use rule data for a data item available from the data supplier.
38. A data access terminal as claimed in claim 37 further comprising code to write use rule data for a data item into the data carrier with the associated data item.
39. A data access terminal as claimed in claim 37 or 38 further comprising code to read a stored value from the data carrier, code to compare said stored value with said value data; and code to provide a modified output to a user of one or more of said stored data identifier data, said value data and said use rule data, in response to a result of the comparison.

40. A data access terminal according to any one of claims 35 to 39 further comprising code for user input of access control data, code to output the access control data to the data carrier, code to receive access permission data from the card, and code to output data to the user in response to the received access permission data.
41. A data access terminal as claimed in claim 40 further comprising code to output a data erasure warning in response to the received access permission data.
42. A data access terminal according to any one of claims 35 to 41 further comprising code to read reward data from the data carrier and to write modified reward data to the data carrier in response to said retrieval of data from the data supplier.
43. A data access terminal according to any one of claims 35 to 42 further comprising:
code to read identity data from the data carrier;
code to transmit the identity data to the data supplier;
code to receive user characterising data from the data supplier;
code to retrieve supplementary data in response to said characterising data; and
code to output the supplementary data.
44. A data access terminal according to any one of claims 35 to 43 further comprising a cash input device coupled to the processor, to provide cash input value data; and code to update payment data in the data carrier, in accordance with the cash input value data.
45. A data access terminal according to any one of claims 35 to 44 integrated with a mobile communication device, a personal computer, an audio/video player, and/or a cable or satellite television interface device.
46. A method of providing data from a data supplier to a data carrier, the method comprising:

reading payment data from the data carrier;
forwarding the payment data to a payment validation system;
retrieving data from the data supplier; and
writing the retrieved data into the data carrier.

47. A method of providing data from a data supplier according to claim 46 further comprising:
receiving payment validation data from the payment validation system; and
transmitting at least a portion of the payment validation data to the data supplier.
48. A method of providing data as claimed in claim 47, wherein the payment validation system comprises a payment processor at the data supplier.
49. A method of providing data as claimed in claim 46, 47 or 48, further comprising:
retrieving from the data supplier a stored data item identifier and associated value data and use rule data; and
writing use rule data for the data item into the data carrier.
50. A method of providing data as claimed in claim 48 or 49, further comprising:
reading a stored value from the data carrier;
comparing the stored value with said value data; and
outputting to a user information indicating the result of said comparing.
51. A data access device for retrieving stored data from a data carrier, the device comprising:
a user interface;
a data carrier interface;
a program store storing code implementable by a processor; and
a processor coupled to the user interface, to the data carrier interface and to the program store for implementing the stored code, the code comprising:

code to retrieve use status data indicating a use status of data stored on the carrier, and use rules data indicating permissible use of data stored on the carrier;
code to evaluate the use status data using the use rules data to determine whether access is permitted to the stored data; and
code to access the stored data when access is permitted.

52. A data access device according to claim 51, further comprising code to write updated use status data to the carrier after user access to the stored data.

53. A data access device as claimed in claim 51 or 52, further comprising user access control code to input user access data, to transmit the user access data to the carrier, and to receive from the carrier user access permission data.

54. A data access device according to claim 53, further comprising code to select the use status and use rules data using the user access data.

55. A data access device as claimed in claim 53 or 54, further comprising code to retrieve and output supplementary data to the user.

56. A data access device according to any one of claims 51 to 55 wherein said use rules permit partial use of a data item stored on the carrier and further comprising code to write partial use status data to the data carrier when only part of a stored data item has been accessed.

57. A data access device according to any one of claims 51 to 56 wherein the device is portable and the data carrier interface is configured for interfacing with a removable data carrier.

58. A data access device according to claim 57 configured to interface with the data carrier of any one of claims 10 to 21.

59. A method of controlling access to data from a data carrier, comprising:
retrieving use status data from the data carrier indicating past use of the stored data;
retrieving use rules from the data carrier;
evaluating the use status data using the use rules to determine whether access to data stored on the carrier is permitted; and
permitting access to the data on the data carrier dependent on the result of said evaluating.
60. A method of controlling access according to claim 59, further comprising:
writing updated use status data to the carrier after an access attempt.
61. A method of controlling access according to claim 60, wherein said use rules permit partial access to a data item and wherein said writing writes a record of what part of the data item has been accessed when only part of the data item has been accessed.
62. A method of controlling access according to any one of claims 59 to 61, further comprising:
inputting a user access data;
selecting the use rules dependent upon the user access data.
63. A data access system comprising a data supply computer system for forwarding data from a data provider to a data access terminal; an electronic payment system for confirming an electronic payment; a data access terminal for communicating with the data supply system to write data from the data supply system onto a data carrier; and a data carrier for storing data from the data supply system and payment data; wherein data is forwarded from the data provider to the data carrier on validation of payment data provided from the data carrier to the electronic payment system.
64. A data access system according to claim 63 further comprising a payment distribution store and wherein the electronic payment system makes payments according

to data in the payment distribution store associated with the forwarded data on confirmation of the payment and/or provision of the forwarded data to the card.

65. A data access system according to claim 63 or 64 further comprising a data use rule data store and wherein data use rule data is provided to the data carrier with the forwarded data for controlling user access to the forwarded data.

66. A data access system according to claim 65 wherein the data use rule data is selected dependent upon the payment data.

67. A portable data carrier comprising:
an interface for sending and receiving data from and to the carrier;
non-volatile data memory, coupled to the interface, for storing data on the carrier; and
a digital rights management processor for controlling access to the stored data.

68. A portable data carrier comprising:
an interface for sending and receiving data from and to the carrier;
non-volatile data memory, coupled to the interface, for storing data on the carrier; and
an access control processor;
wherein the data memory is partitioned as data blocks and the access control processor controls external access to the data blocks.

69. A computer system for providing data to a data requester, the system comprising:
a communication interface;
a data access data store for storing records of data items available from the system, each record comprising a data item description and a resource locator a data provider for the data item;
a program store storing code implementable by a processor;

a processor coupled to the communications interface, to the data access data store, and to the program store for implementing the stored code, the code comprising:
code to receive a request for a data item from the requester to receive from the communications interface payment data comprising data relating to payment for the requested data item;

code, responsive to the request and to the received payment data to output the item data to the requester over the communication interface; wherein

said data access data store further comprises payment distribution information indicating to whom payments should be made for a data item; and

further comprising code to output payment data for a data item for making payments for the item when the item is supplied to a said requester.

70. A computer system for providing data to a data requester, the system comprising:

a communication interface;

a data access data store for storing records of data items available from the system, each record comprising a data item description and location data identifying an electronic address for a provider for the data item;

a program store storing code implementable by a processor;

a processor coupled to the communications interface, to the data access data store, and to the program store for implementing the stored code, the code comprising:

code to receive a request for a data item from the requester to receive from the communications interface payment data comprising data relating to payment for the requested data item;

code responsive to the request and to the received payment data to output the item data to the requester over the communication interface; wherein

said data access data store further comprises data item access rule data for output to the requester with a said data item; and

further comprising code to select access rule data for output with a data item in response to said payment data.

71. A method of providing data to a data requester comprising:
receiving a request for a data item from the requester;
receiving payment data from the requester relating to payment for the requested data;
transmitting the requested data to the requester;
reading payment distribution information from a data store; and
outputting payment data to a payment system for distributing the payment for the requested data.
72. A method of providing data to a data requester comprising:
receiving a request for a data item from the requester;
receiving payment data from the requester relating to payment for the requested data;
transmitting the requested data to the requester; and
transmitting data access rule data to requester with the read data.
73. A computer program to, when running, carry out the method of any preceding method claim.
74. A computer readable medium carrying the computer program of claim 73.

ABSTRACT

Data storage and access systems are described for downloading and paying for data such as audio and video data, text, software, games and other types of data. A portable data carrier has an interface for sending and receiving data, non-volatile data memory for storing received content data and non-volatile payment validation memory for providing payment validation data to an external device. The carrier may also store a record of access made to the stored content, and content use rules for controlling access to the stored content. Preferred embodiments store further access control data and supplementary data such as hot links to web sites and/or advertising data. A complementary data access terminal, data supply computer system and data access device are also described. The combination of payment data and stored content data and, in preferred embodiments, use rule data, helps reduce the risk of unauthorized access to data such as compressed music and video data, especially over the Internet.

SF 1340006 v1

1/17
Fig. 1
A

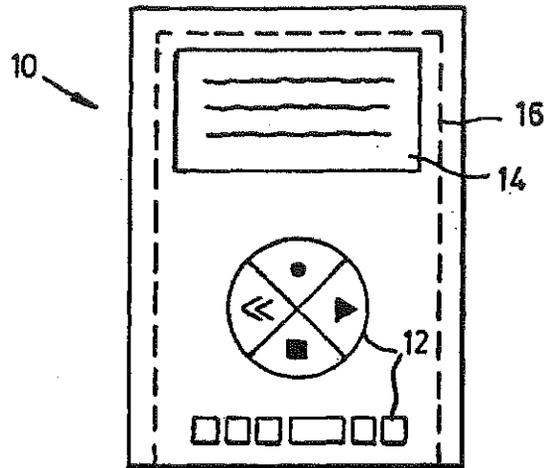

B

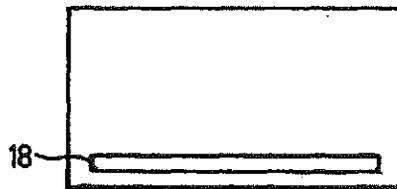

C

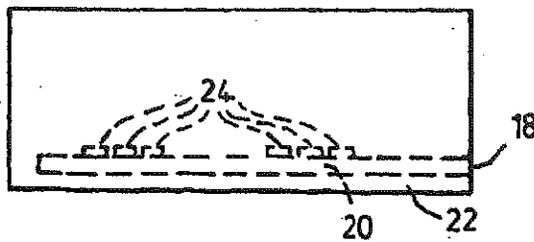

SUBSTITUTE SHEET (RULE 26)

BEST AVAILABLE COPY

Fig. 2

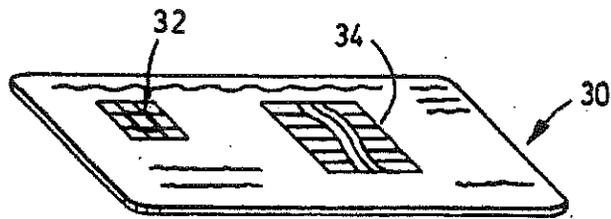
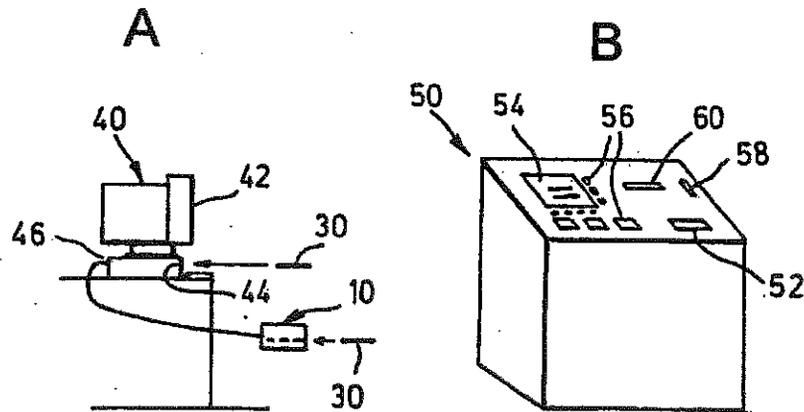

Fig. 3



SUBSTITUTE SHEET (RULE 26)

3/17

Fig. 4
A

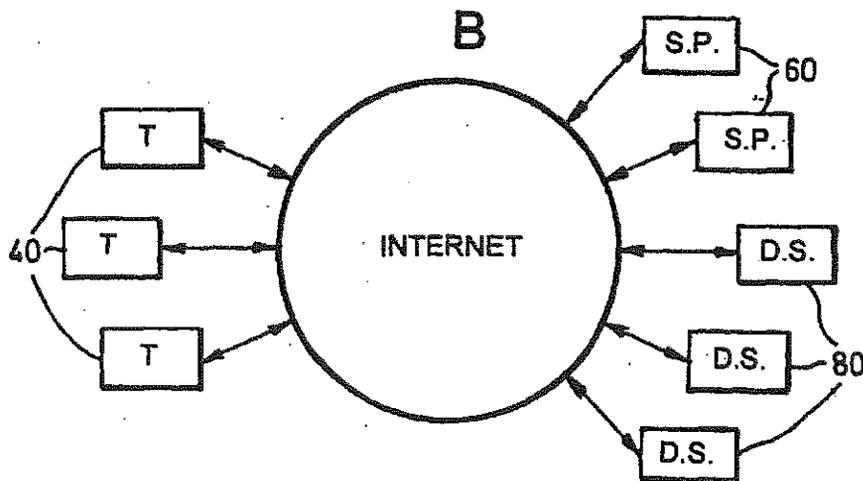
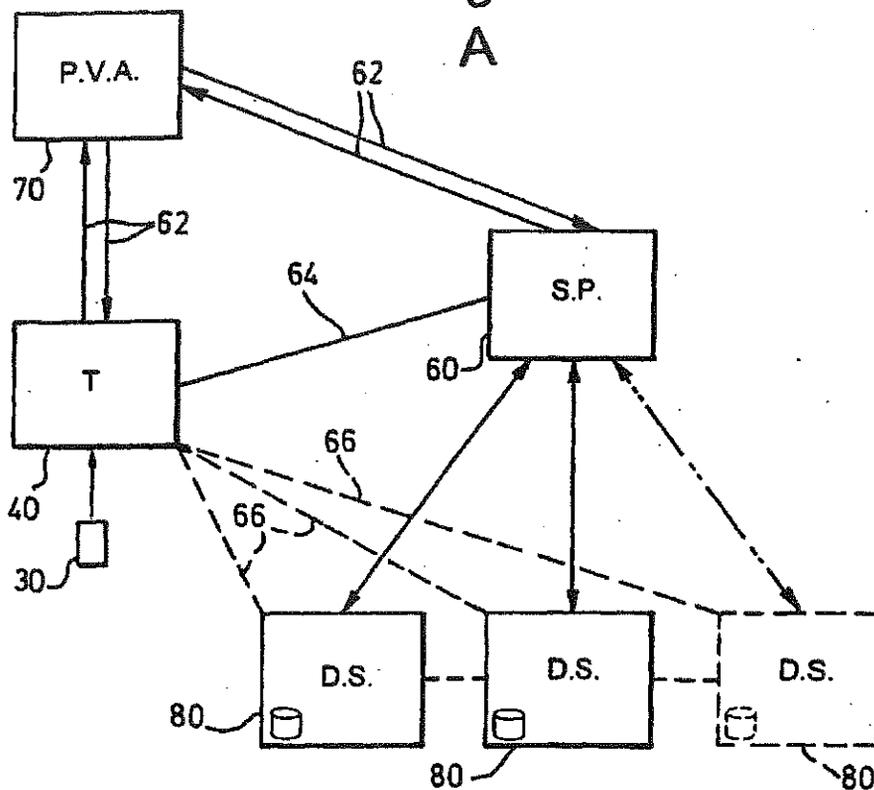

SUBSTITUTE SHEET (RULE 26)

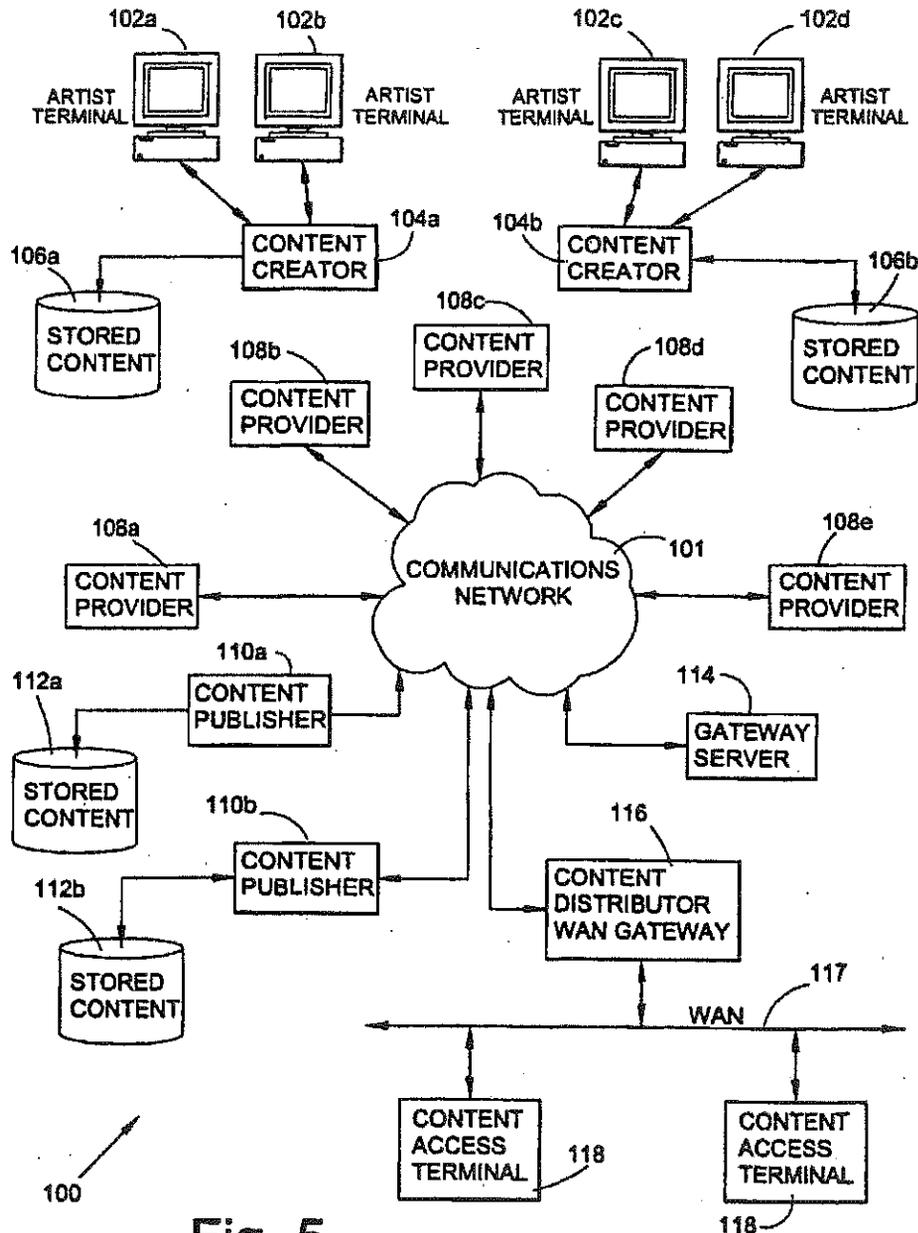

Fig. 5

SUBSTITUTE SHEET (RULE 26)

5/17

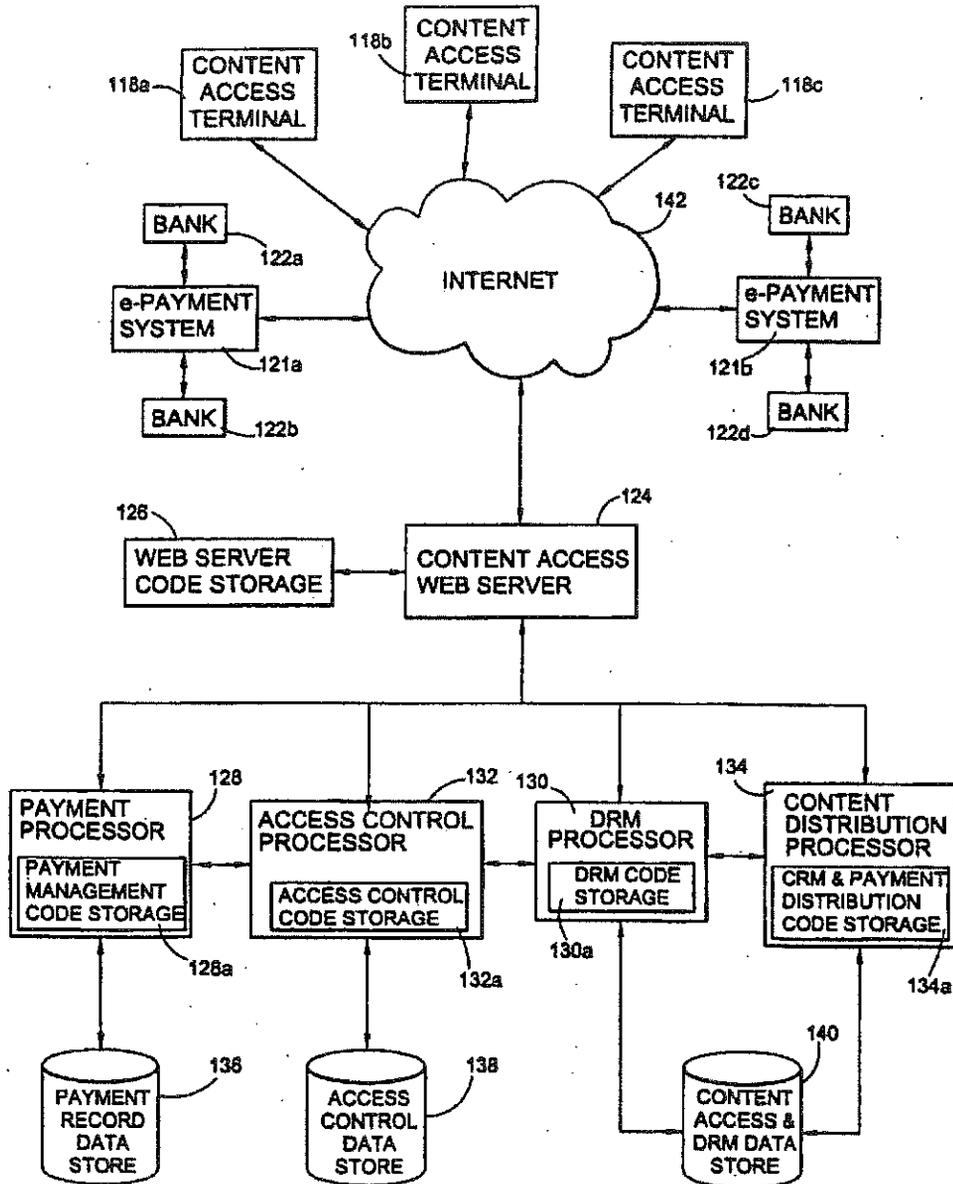

Fig.6

120

6/17

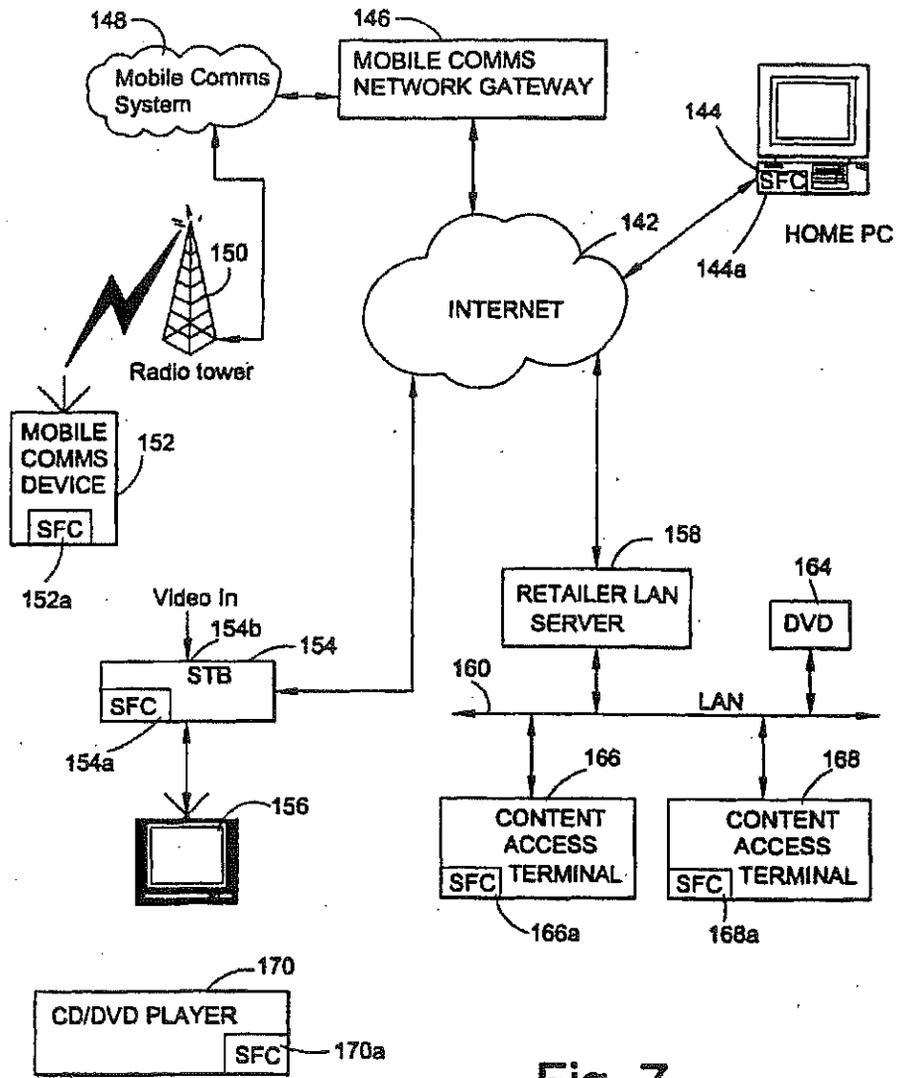

Fig. 7

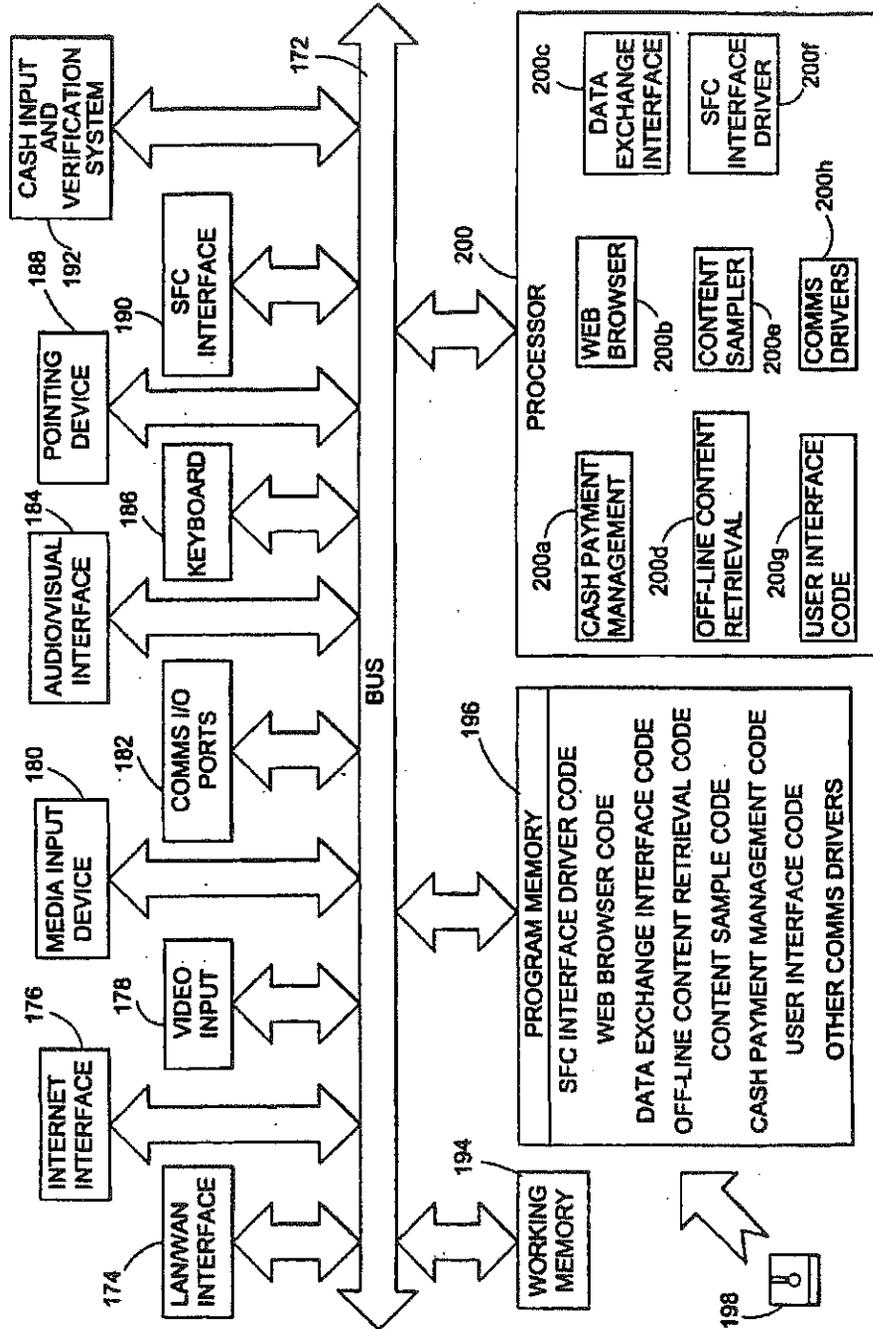

Fig. 8

8/17

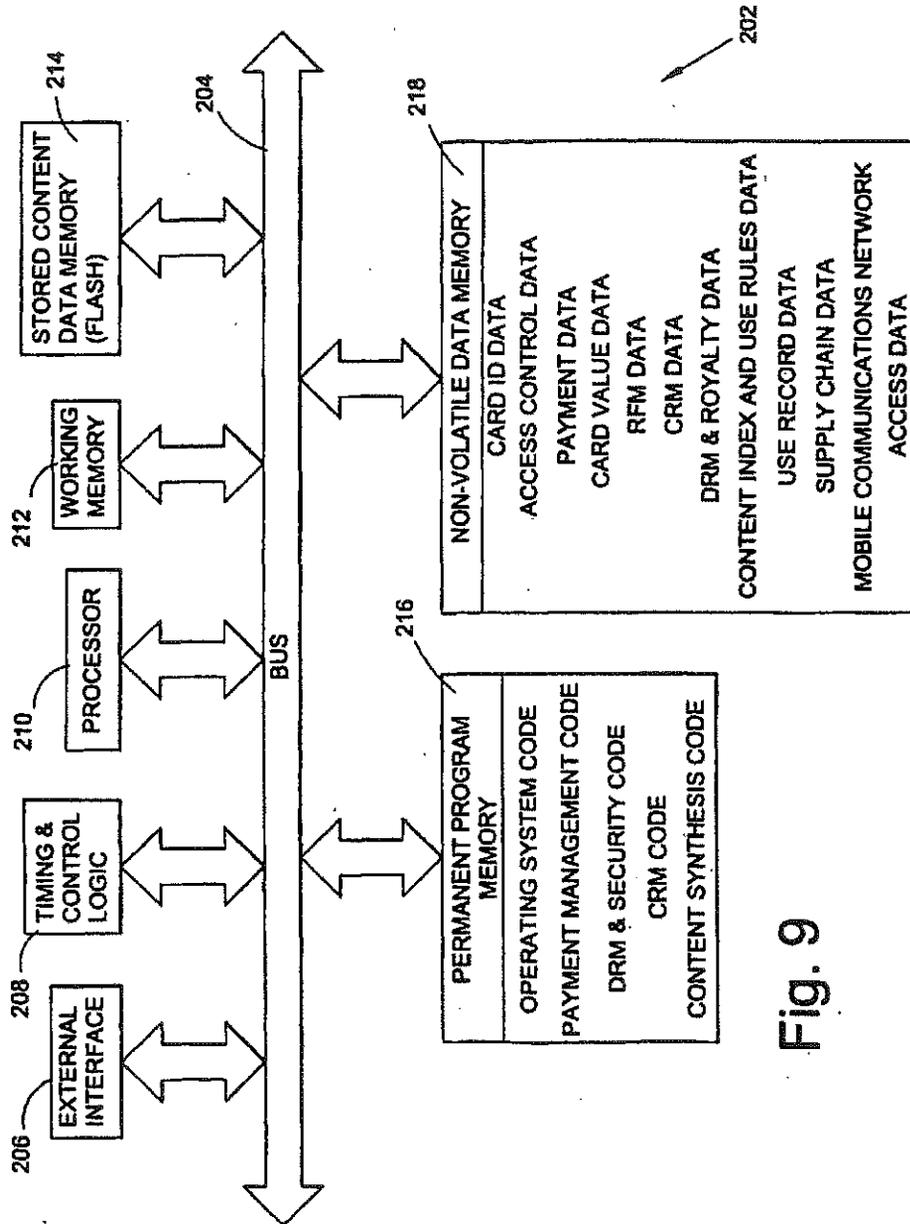

Fig. 9

9/17

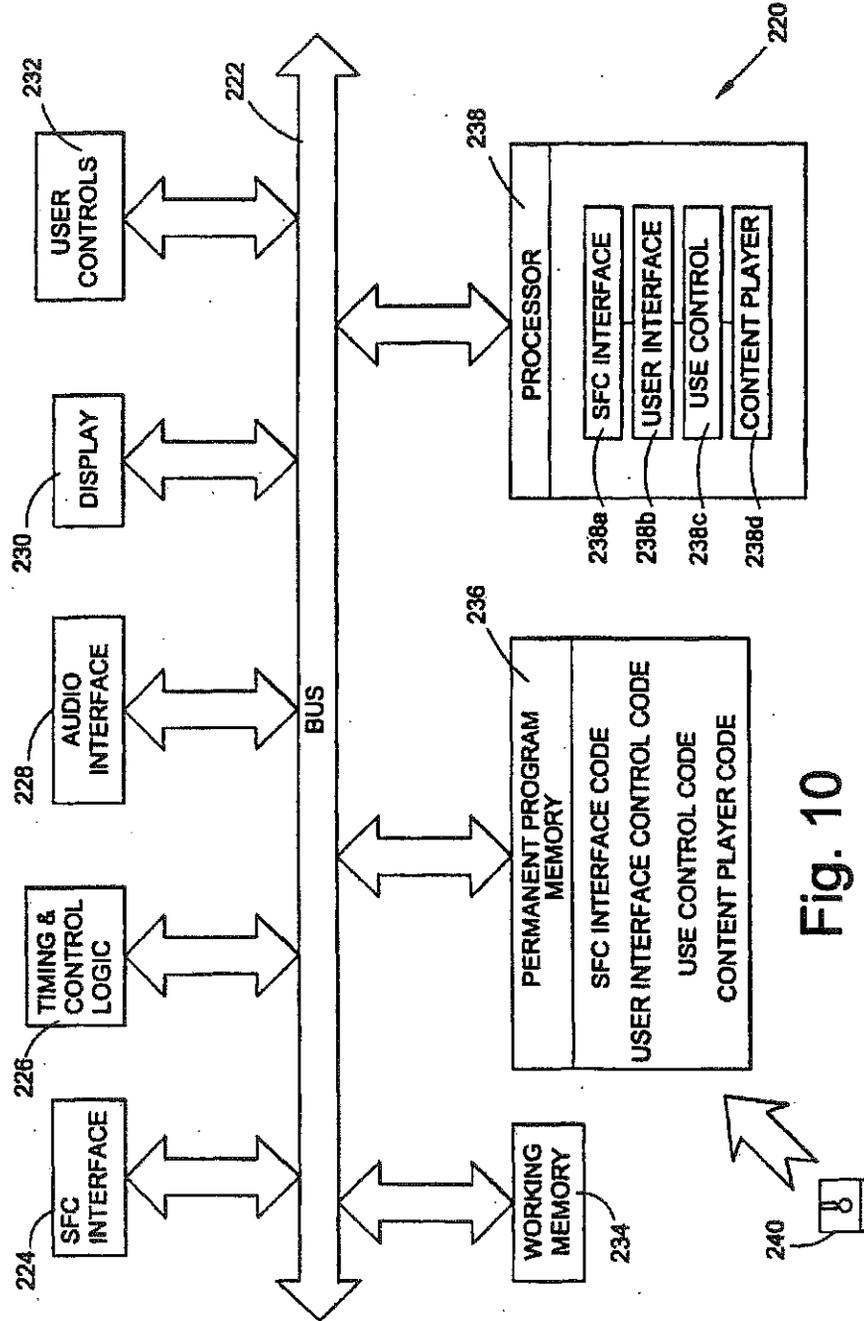

Fig. 10

SUBSTITUTE SHEET (RULE 26)

10/17

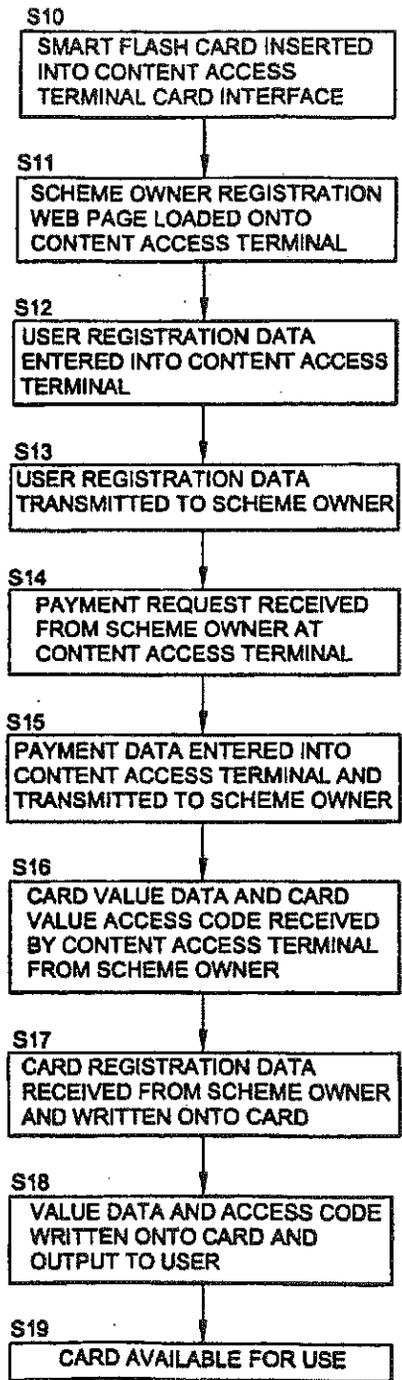

Fig11a

SUBSTITUTE SHEET (RULE 26)

11/17

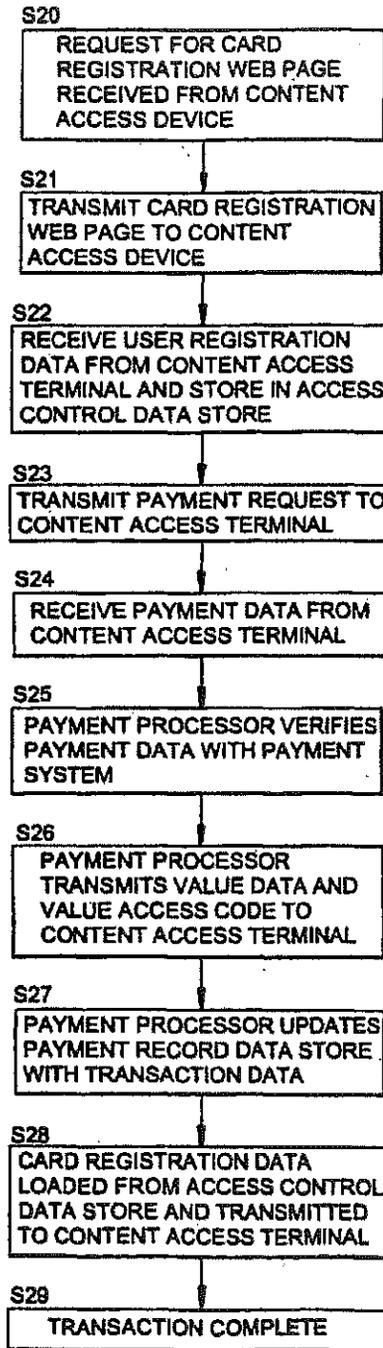

Fig.11b

12/17

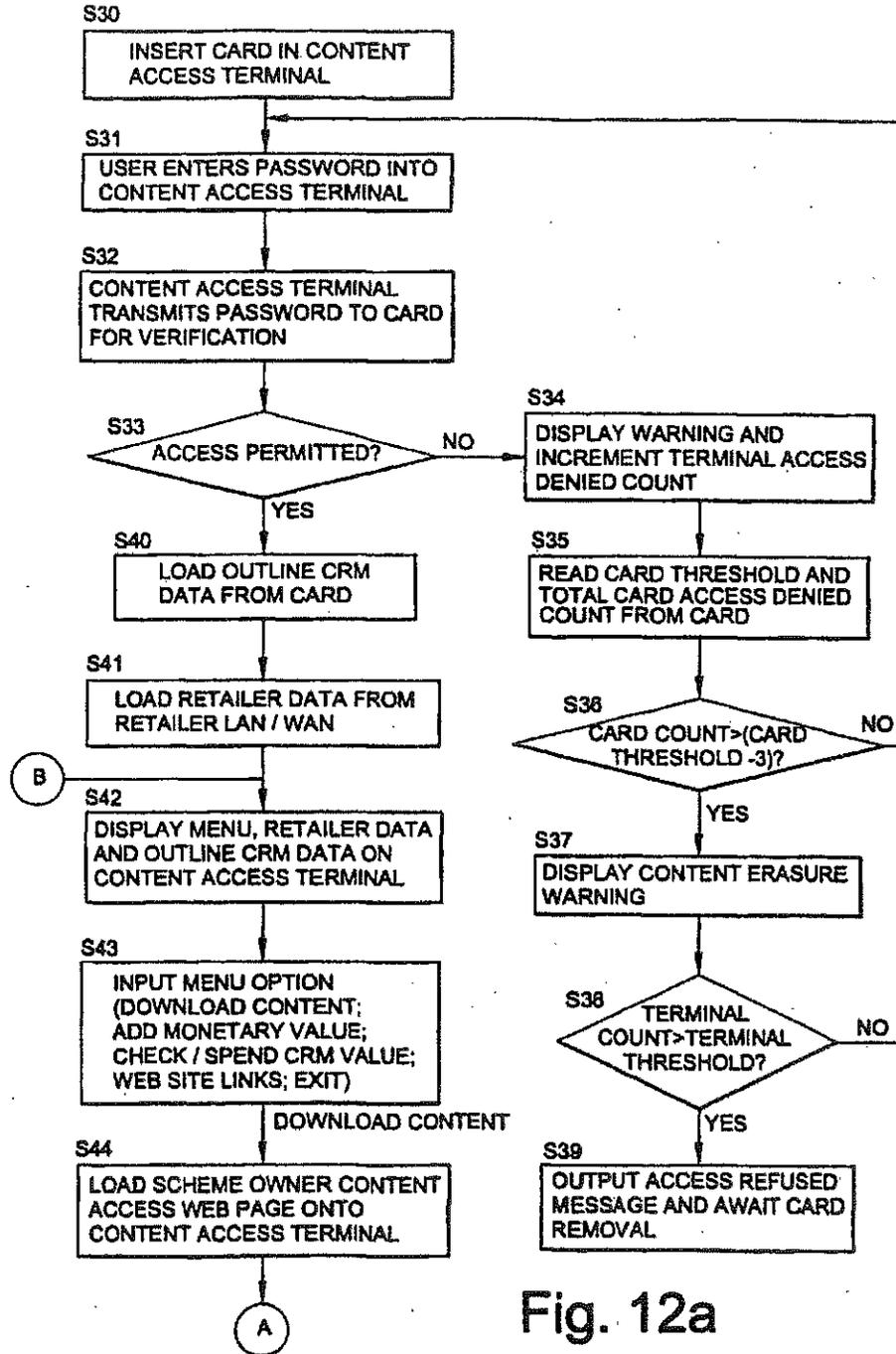

Fig. 12a

SUBSTITUTE SHEET (RULE 26)

13/17

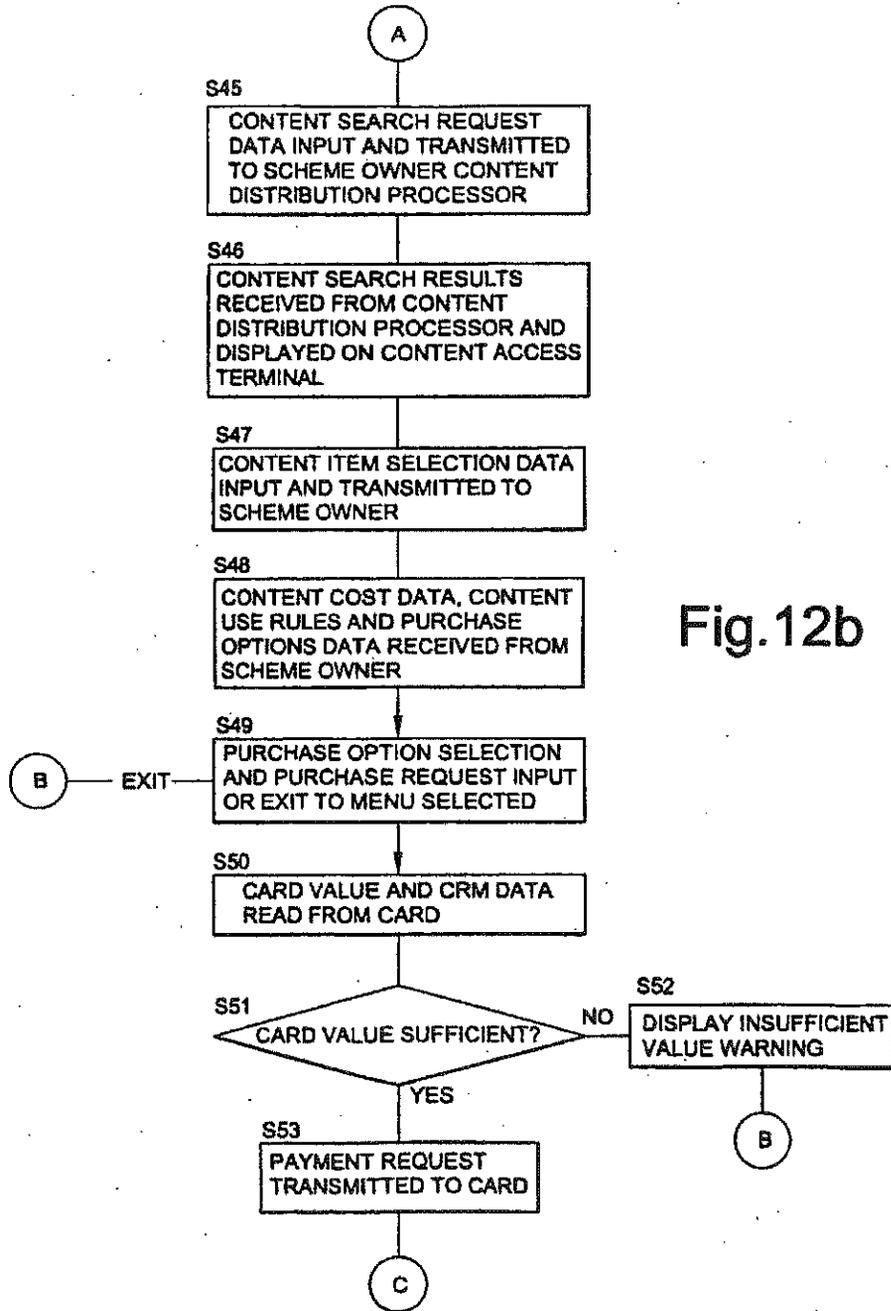

Fig.12b

SUBSTITUTE SHEET (RULE 26)

14/17

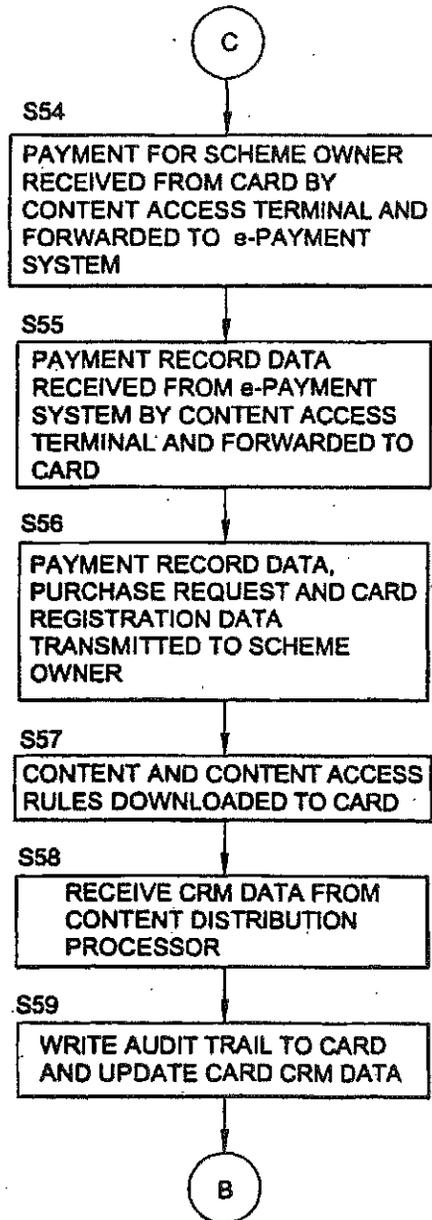

Fig.12c

15/17

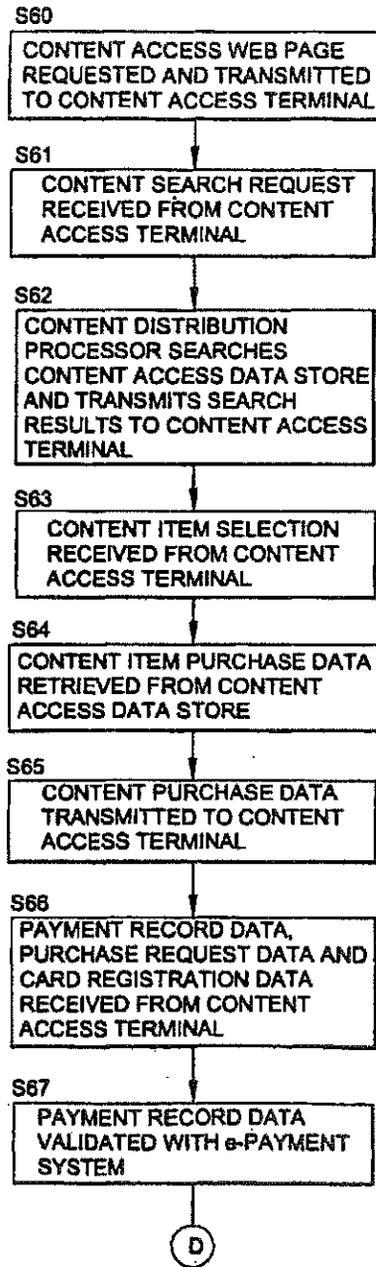

Fig. 12d

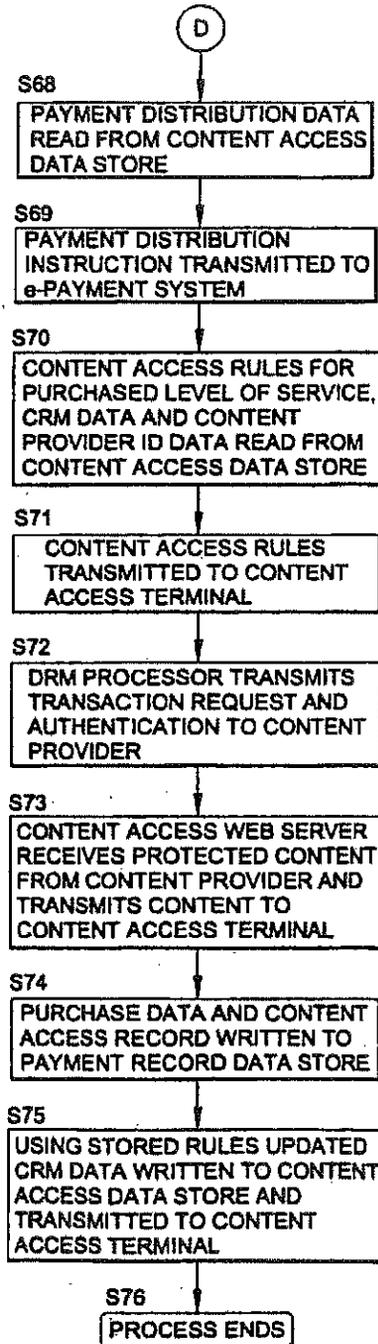

Fig. 12e

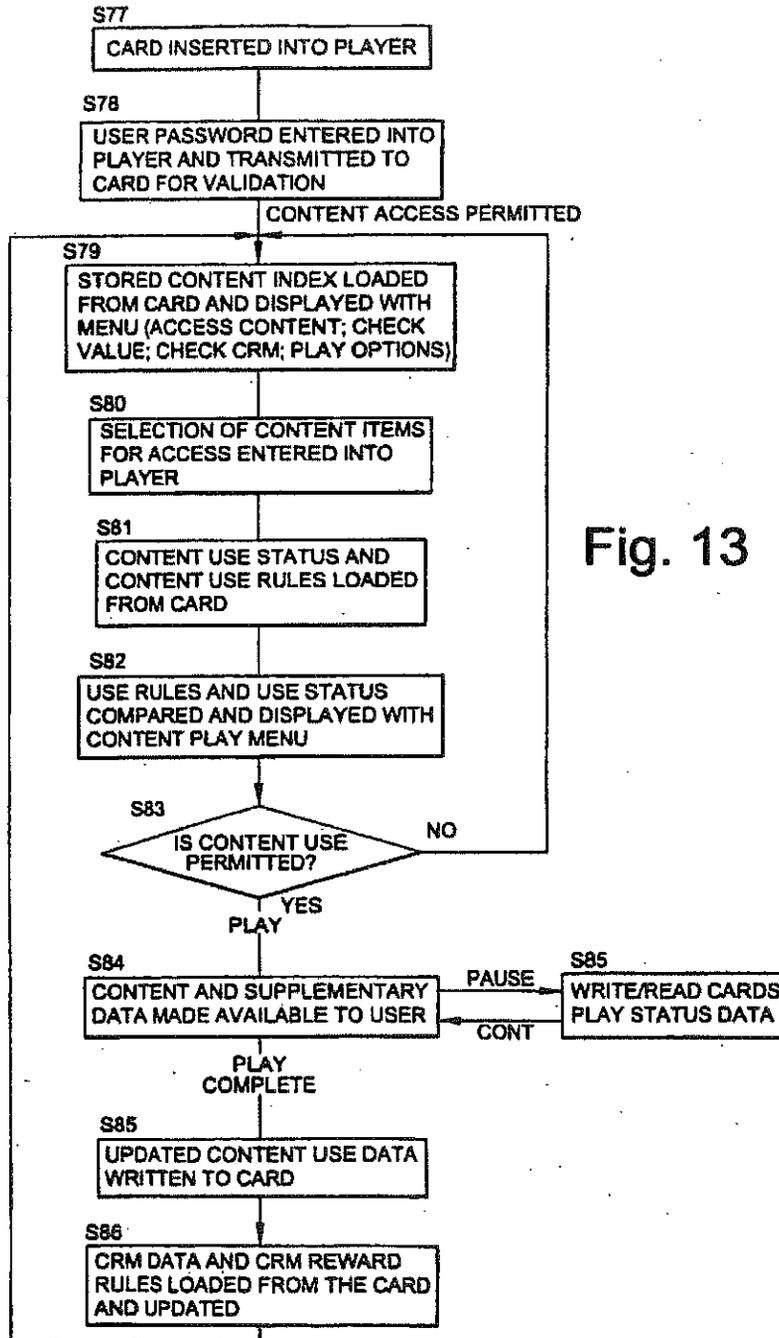

Fig. 13

**This Page is Inserted by IFW Indexing and Scanning
Operations and is not part of the Official Record**

BEST AVAILABLE IMAGES

Defective images within this document are accurate representations of the original documents submitted by the applicant.

Defects in the images include but are not limited to the items checked:

- BLACK BORDERS**
- IMAGE CUT OFF AT TOP, BOTTOM OR SIDES**
- FADED TEXT OR DRAWING**
- BLURRED OR ILLEGIBLE TEXT OR DRAWING**
- SKEWED/SLANTED IMAGES**
- COLOR OR BLACK AND WHITE PHOTOGRAPHS**
- GRAY SCALE DOCUMENTS**
- LINES OR MARKS ON ORIGINAL DOCUMENT**
- REFERENCE(S) OR EXHIBIT(S) SUBMITTED ARE POOR QUALITY**
- OTHER: _____**

IMAGES ARE BEST AVAILABLE COPY.

As rescanning these documents will not correct the image problems checked, please do not report these problems to the IFW Image Problem Mailbox.

| | | |
|--|--------------------------|-------------------|
| DECLARATION FOR UTILITY OR DESIGN PATENT APPLICATION (37 CFR 1.63) <input type="checkbox"/> Declaration Submitted With Initial Filing OR <input checked="" type="checkbox"/> Declaration Submitted after Initial Filing (surcharge (37 CFR 1.16(e)) required) | Attorney Docket Number | 080379-000000US |
| | First Named Inventor | HULST, Hermen-ard |
| | COMPLETE IF KNOWN | |
| | Application Number | 10/111,716 |
| | Filing Date | October 25, 2000 |
| | Art Unit | |
| Examiner Name | | |

As the below named inventor, I hereby declare that:

My residence, mailing address, and citizenship are as stated below next to my name.

I believe I am the original and first inventor of the subject matter which is claimed and for which a patent is sought on the invention entitled:

DATA STORAGE AND ACCESS SYSTEMS

(Title of the invention)

the specification of which

is attached hereto

OR

was filed on (MM/DD/YYYY) 10/25/00 as United States Application Number or PCT International

Application Number 10/111,716 and was amended on (MM/DD/YYYY) (if applicable).

I hereby state that I have reviewed and understand the contents of the above identified specification, including the claims, as amended by any amendment specifically referred to above.

I acknowledge the duty to disclose information which is material to patentability as defined in 37 CFR 1.56, including for continuation-in-part applications, material information which became available between the filing date of the prior application and the national or PCT international filing date of the continuation-in-part application.

I hereby claim foreign priority benefits under 35 U.S.C. 119(a)-(d) or (f), or 365(b) of any foreign application(s) for patent, inventor's or plant breeder's rights certificate(s), or 365(a) of any PCT international application which designated at least one country other than the United States of America, listed below and have also identified below, by checking the box, any foreign application for patent, inventor's or plant breeder's rights certificate(s), or of any PCT international application having a filing date before that of the application on which priority is claimed.

| Prior Foreign Application Number(s) | Country | Foreign Filing Date (MM/DD/YYYY) | Priority Not Claimed | Certified Copy Attached? | |
|-------------------------------------|---------------|----------------------------------|--------------------------|--------------------------|-------------------------------------|
| | | | | YES | NO |
| 9925227.2 | Great Britain | 10/25/1999 | <input type="checkbox"/> | <input type="checkbox"/> | <input checked="" type="checkbox"/> |
| | | | <input type="checkbox"/> | <input type="checkbox"/> | <input type="checkbox"/> |
| | | | <input type="checkbox"/> | <input type="checkbox"/> | <input type="checkbox"/> |
| | | | <input type="checkbox"/> | <input type="checkbox"/> | <input type="checkbox"/> |

Additional foreign application numbers are listed on a supplemental priority data sheet PTO/SB/02B attached hereto:

DECLARATION — Utility or Design Patent Application

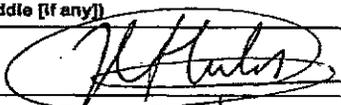
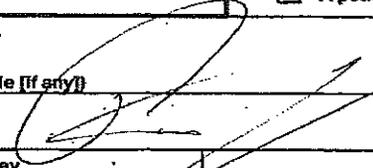
| | | | |
|---|-----------|---|--------------------------|
| Direct all correspondence to: <input checked="" type="checkbox"/> Customer Number or Bar Code Label 20350 OR <input type="checkbox"/> Correspondence address below | | | |
| Name | | | |
| Address | | | |
| City | | State | ZIP |
| Country | Telephone | | Fax |
| I hereby declare that all statements made herein of my own knowledge are true and that all statements made on information and belief are believed to be true; and further that these statements were made with the knowledge that willful false statements and the like so made are punishable by fine or imprisonment, or both, under 18 U.S.C. 1001 and that such willful false statements may jeopardize the validity of the application or any patent issued thereon. | | | |
| NAME OF SOLE OR FIRST INVENTOR: | | <input type="checkbox"/> A petition has been filed for this unsigned inventor | |
| Hermen-ard Given Name (first and middle (if any)) | | ...HULST Family Name or Surname | |
| Inventor's Signature:  | | Date: June 12 th 2002 | |
| Amsterdam Residence: City | State | Netherlands Country | Dutch Citizenship |
| Van Tuyll van Serooskerkenweg 75h ^S Mailing Address | | | |
| Amsterdam City | State | 1076 JG ZIP | Netherlands Country |
| NAME OF SECOND INVENTOR: | | <input type="checkbox"/> A petition has been filed for this unsigned inventor | |
| Patrick Sandor Given Name (first and middle (if any)) | | RACZ Family Name or Surname | |
| Inventor's Signature:  | | Date: 12/5/02 | |
| St. Heller, Jersey Residence: City | State | Great Britain Country | GB Citizenship |
| 19 Royal Square Mailing Address | | | |
| St. Heller, Jersey City | State | JE1 4WA ZIP | Great Britain Country |
| <input type="checkbox"/> Additional Inventors are being named on the _____ supplemental Additional Inventor(s) sheet(s) PTO/SB/02A attached hereto. | | | |

[Page 2 of 2]

SF 1340208 v1

BEST AVAILABLE COPY

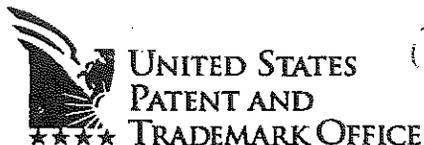

080379-005 KTL

APRIL 21, 2003

Under Secretary of Commerce For Intellectual Property and
Director of the United States Patent and Trademark Office
Washington, DC 20231
www.uspto.gov

PTAS
TOWNSEND AND TOWNSEND AND CREW LLP
KEVIN T. LEMOND
TWO EMBARCADERO CENTER, 8TH FLOOR
SAN FRANCISCO, CALIFORNIA 94111-3834



102317843A

UNITED STATES PATENT AND TRADEMARK OFFICE
NOTICE OF RECORDATION OF ASSIGNMENT DOCUMENT

THE ENCLOSED DOCUMENT HAS BEEN RECORDED BY THE ASSIGNMENT DIVISION OF THE U.S. PATENT AND TRADEMARK OFFICE. A COMPLETE MICROFILM COPY IS AVAILABLE AT THE ASSIGNMENT SEARCH ROOM ON THE REEL AND FRAME NUMBER REFERENCED BELOW.

PLEASE REVIEW ALL INFORMATION CONTAINED ON THIS NOTICE. THE INFORMATION CONTAINED ON THIS RECORDATION NOTICE REFLECTS THE DATA PRESENT IN THE PATENT AND TRADEMARK ASSIGNMENT SYSTEM. IF YOU SHOULD FIND ANY ERRORS OR HAVE QUESTIONS CONCERNING THIS NOTICE, YOU MAY CONTACT THE EMPLOYEE WHOSE NAME APPEARS ON THIS NOTICE AT 703-308-9723. PLEASE SEND REQUEST FOR CORRECTION TO: U.S. PATENT AND TRADEMARK OFFICE, ASSIGNMENT DIVISION, BOX ASSIGNMENTS, CG-4, 1213 JEFFERSON DAVIS HWY, SUITE 320, WASHINGTON, D.C. 20231.

RECORDATION DATE: 09/17/2002

REEL/FRAME: 013583/0554
NUMBER OF PAGES: 2

BRIEF: ASSIGNMENT OF ASSIGNOR'S INTEREST (SEE DOCUMENT FOR DETAILS).

ASSIGNOR:
HULST, HERMEN-ARD

DOC DATE: 06/12/2002

ASSIGNEE:
SMART-FLASH LIMITED
UPPER NORDENS, HIGH HURST WOOD
UCKFIELD, EAST SUSSEX, GREAT
BRITAIN
TN22 4AN

SERIAL NUMBER: 10111716
PATENT NUMBER:

FILING DATE: 09/17/2002
ISSUE DATE:

ALLYSON PURNELL, EXAMINER
ASSIGNMENT DIVISION
OFFICE OF PUBLIC RECORDS

BEST AVAILABLE COPY

9/17/02

12-20-2002

by Docket No. 080379-000000US

Form PTO-1595
(Rev. 03-01)
OMB No. 0651-0027 (exp. 5/31/2002)



U.S. Department of Commerce
U.S. Patent and Trademark Office

Tab settings >>>

102317843

To the Honorable Commissioner of Patents and Trademarks. Please record the attached original documents or copy thereof

1. Name of conveying party(ies):
Hermen-Ard Hulst

Additional name(s) of conveying parties attached? Yes No.

2. Name and address of receiving party(ies)
Name: Smart-Flash Limited
Street Address: Upper Nordens, High Hurst Wood

3. Nature of conveyance:
 Assignment Merger
 Security Agreement Change of Name
 Other: _____

Execution Date: June 12, 2002

City: Uckfield, East Sussex State: Great Britain Zip: TN22 4AN

Additional names and addresses attached? Yes No

4. Application number(s) or patent number(s).
If this document is being filed together with a new application, the execution date of the application is: _____
A. Patent Application No(s): 10/111,716
B. Patent No(s): _____
Additional numbers attached? Yes No

5. Name and address of party to whom correspondence concerning document should be mailed:
Name: Kevin T. LeMond
TOWNSEND AND TOWNSEND AND CREW LLP
Two Embarcadero Center, 8th Floor
San Francisco, California 94111-3834
(415) 576-0200

09/23/2002 LLANDGRA 00000047 201430 10111716
03 FC:581 40.00 CH

6. Total number of applications and patents involved 1
7. Total fee (37 CFR 3.41): _____ \$40.00
 Enclosed
 Authorized to be charged to deposit account
8. Deposit account number: 20-1430
(Attach duplicate copy of this page if paying by deposit account)

DO NOT USE THIS SPACE

9. Statement and signature.
To the best of my knowledge and belief, the foregoing is true and correct and any attached copy is a true of copy of the original document.

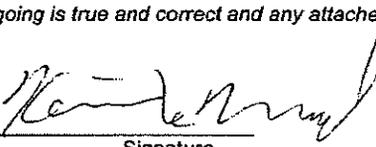
Kevin T. LeMond  September 17, 2002
Name of Person Signing Signature Date
Atty. Reg. No. 35,933

Total number of pages including cover sheet, attachments and document 2
Mail documents to be recorded with required cover sheet Information to:
Commissioner of Patents and Trademarks, Box Assignments
Washington, D.C. 20231

BEST AVAILABLE COPY

ASSIGNMENT OF PATENT APPLICATION

WHEREAS, Hermen-ard HULST, Van Tuyll van Serooskerkenweg 75hs, 1076 JG Amsterdam The Netherlands ~~Patrick Sandor RACZ, of 19 Royal Square, St. Helier, Jersey JE1 4WA, Great Britain~~, hereinafter referred to as "Assignors", are the inventors of the invention described and set forth in the below identified application for United States Letters Patent:

Title of the Invention: DATA STORAGE AND ACCESS SYSTEMS

Date(s) of execution: _____

Filing date: October 25, 2000 Serial No.: 10/111,716; and

WHEREAS, SMART-FLASH LIMITED, Upper Nordens, High Hurst Wood, Uckfield, East Sussex TN22 4AN, Great Britain, hereinafter referred to as "Assignee", is desirous of acquiring Assignors' interest in the said invention and application and in any U.S. Letters Patent which may be granted on the same;

NOW, THEREFORE, TO ALL WHOM IT MAY CONCERN: Be it known that, for good and valuable consideration, receipt of which is hereby acknowledged by Assignors, Assignors have sold, assigned and transferred, and by these presents do sell, assign and transfer unto the said Assignee, and Assignee's successors and assigns, all their right, title and interest in and to the said invention and application and all future improvements thereon, and in and to any Letters Patent which may hereafter be granted on the same in the United States, the said interest to be held and enjoyed by said Assignee as fully and exclusively as it would have been held and enjoyed by said Assignor had this Assignment and transfer not been made, to the full end and term of any Letters Patent which may be granted thereon, or of any division, renewal, continuation in whole or in part, substitution, conversion, reissue, prolongation or extension thereof.

Assignors further agree that they will, without charge to said Assignee, but at Assignee's expense, cooperate with Assignee in the prosecution of said application and/or applications, execute, verify, acknowledge and deliver all such further papers, including applications for Letters Patent and for the reissue thereof, and instruments of assignment and transfer thereof, and will perform such other acts as Assignee lawfully may request, to obtain or maintain Letters Patent for said invention and improvement, and to vest title thereto in said Assignee, or Assignee's successors and assigns.

IN TESTIMONY WHEREOF, Assignors have signed their names on the dates indicated.

Date: June 12th 2002

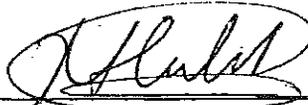
Hermen-ard HULST

Date: _____
Patrick Sandor RACZ

PATENT APPLICATION SERIAL NO _____

U.S. DEPARTMENT OF COMMERCE
PATENT AND TRADEMARK OFFICE
FEE RECORD SHEET

01/25/2006 MWDLGE1 00000089 201430 11336758

| | |
|------------|------------|
| 01 FC:2011 | 150.00 DA |
| 02 FC:2111 | 250.00 DA |
| 03 FC:2311 | 100.00 DA |
| 04 FC:2201 | 1100.00 DA |
| 05 FC:2202 | 1350.00 DA |

PTO-1556
(5/87)

Under the Paperwork Reduction Act of 1995, no persons are required to respond to a collection of information unless it displays a valid OMB control number.

PATENT APPLICATION FEE DETERMINATION RECORD
 Substitute for Form PTO-675 Effective December 8, 2004

Application or Docket Number
 11336758

| APPLICATION AS FILED - PART I | | | SMALL ENTITY | | OTHER THAN SMALL ENTITY | |
|---|---|--------------|--------------|----------|-------------------------|----------|
| (Column 1) | (Column 2) | | RATE (\$) | FEE (\$) | RATE (\$) | FEE (\$) |
| FOR | NUMBER FILED | NUMBER EXTRA | | | | |
| BASIC FEE (37 CFR 1.16(a), (b), or (c)) | N/A | N/A | N/A | 150.00 | N/A | 300.00 |
| SEARCH FEE (37 CFR 1.18(k), (l), or (m)) | N/A | N/A | N/A | \$250 | N/A | \$500 |
| EXAMINATION FEE (37 CFR 1.16(d), (e), or (f)) | N/A | N/A | N/A | \$100 | N/A | \$200 |
| TOTAL CLAIMS (37 CFR 1.16(i)) | 74 minus 20 = | 54 | X\$ 25 = | 1350 | X\$50 = | |
| INDEPENDENT CLAIMS (37 CFR 1.16(h)) | 14 minus 3 = | 11 | X100 = | 1100 | X200 = | |
| APPLICATION SIZE FEE (37 CFR 1.16(s)) | If the specification and drawings exceed 100 sheets of paper, the application size fee due is \$250 (\$125 for small entity) for each additional 50 sheets or fraction thereof. See 35 U.S.C. 41(a)(1)(G) and 37 CFR 1.16(s). | | | | | |
| MULTIPLE DEPENDENT CLAIM PRESENT (37 CFR 1.16(j)) | | | +180= | | +360= | |
| * If the difference in column 1 is less than zero, enter "0" in column 2. | | | TOTAL | 2950 | TOTAL | |

| APPLICATION AS AMENDED - PART II | | | | | SMALL ENTITY | | OTHER THAN SMALL ENTITY | |
|---|---------------------------------------|------------------------------------|---------------|---|-----------------|---------------------|-------------------------|---------------------|
| (Column 1) | (Column 2) | | (Column 3) | | RATE (\$) | ADDITIONAL FEE (\$) | RATE (\$) | ADDITIONAL FEE (\$) |
| AMENDMENT A | CLAIMS REMAINING AFTER AMENDMENT | HIGHEST NUMBER PREVIOUSLY PAID FOR | PRESENT EXTRA | | | | | |
| | Total (37 CFR 1.16(i)) | Minus | ** | = | X\$ 25 = | | X\$50 = | |
| | Independent (37 CFR 1.16(i)) | Minus | *** | = | X100 = | | X200 = | |
| | Application Size Fee (37 CFR 1.16(s)) | | | | | | | |
| FIRST PRESENTATION OF MULTIPLE DEPENDENT CLAIM (37 CFR 1.16(j)) | | | | | +180= | | +360= | |
| TOTAL ADD'L FEE | | | | | TOTAL ADD'L FEE | | TOTAL ADD'L FEE | |
| AMENDMENT B | CLAIMS REMAINING AFTER AMENDMENT | HIGHEST NUMBER PREVIOUSLY PAID FOR | PRESENT EXTRA | | | | | |
| | Total (37 CFR 1.16(i)) | Minus | ** | = | X\$ 25 = | | X\$50 = | |
| | Independent (37 CFR 1.16(i)) | Minus | *** | = | X100 = | | X200 = | |
| | Application Size Fee (37 CFR 1.16(s)) | | | | | | | |
| FIRST PRESENTATION OF MULTIPLE DEPENDENT CLAIM (37 CFR 1.16(j)) | | | | | +180= | | +360= | |
| TOTAL ADD'L FEE | | | | | TOTAL ADD'L FEE | | TOTAL ADD'L FEE | |

* If the entry in column 1 is less than the entry in column 2, write "0" in column 3.
 ** If the "Highest Number Previously Paid For" IN THIS SPACE is less than 20, enter "20".
 *** If the "Highest Number Previously Paid For" IN THIS SPACE is less than 3, enter "3".
 The "Highest Number Previously Paid For" (Total or Independent) is the highest number found in the appropriate box in column 1.
 This collection of information is required by 37 CFR 1.16. The information is required to obtain or retain a benefit by the public which is to file (and by the USPTO to process) an application. Confidentiality is governed by 35 U.S.C. 122 and 37 CFR 1.14. This collection is estimated to take 12 minutes to complete, including gathering, preparing, and submitting the completed application form to the USPTO. Time will vary depending upon the individual case. Any comments on the amount of time you require to complete this form and/or suggestions for reducing this burden, should be sent to the Chief Information Officer, U.S. Patent and Trademark Office, U.S. Department of Commerce, P.O. Box 1450, Alexandria, VA 22313-1450. DO NOT SEND FEES OR COMPLETED FORMS TO THIS ADDRESS. SEND TO: Commissioner for Patents, P.O. Box 1450, Alexandria, VA 22313-1450.

PATENT

Attorney Docket No. 080379-000000US
Client Reference No. F/USP8142IX

IN THE UNITED STATES PATENT AND TRADEMARK OFFICE

In re U.S. National Phase of:
PCT/GB/004110

HULST HERMEN-ARD

Application No.: Not yet assigned

Filed: Herewith

For: DATA STORAGE AND ACCESS SYSTEMS

PRELIMINARY AMENDMENT

San Francisco, CA 94111
April 25, 2002

Assistant Commissioner for Patents
Washington, D.C. 20231

Sir:

Prior to the examination of the above-referenced application, please enter the following amendments and remarks.

PLEASE NOTE: The clauses numbered 1-27 beginning at page 44 are not to be included as claims, but as subject matter. The claims at issue begin on page 48 and are number 1-74.

IN THE CLAIMS:

Please substitute the following amended, clean versions of the indicated claims (a marked-up version of the changes to the claims is attached to this Amendment):

3. (amended) A method as claimed in claim 1 further comprising communicating a result of the payment information validating to the data supplier.

4. (amended) A method as claimed in claim 1 further comprising controlling access by the terminal to data from the data supplier using a control data processing system coupled to the Internet.

BEST AVAILABLE COPY

6. (amended) A method as claimed according to claim 1 wherein said coupling is performed by a mobile data retrieval device comprising:
a removable data storage means;
data access means, to access downloaded data on the data storage means;
storage interface means adapted to couple the data storage and data access means;
and data output means to output data derived from the downloaded data, to a user of the device.

7. (amended) A method as claimed in claim 1 further comprising writing into the data storage device data relating to past use made of the downloaded data including data identifying downloaded data items; and/or data identifying data suppliers used; and/or data characterizing a user spending pattern.

8. (amended) A method as claimed in claim 1 wherein said portable data storage device comprises an electronic memory card or smart card.

9. (amended) A method as claimed in claim 1 wherein the downloaded data comprises compressed audio and/or video data.

14. (amended) A portable data carrier as claimed in claim 11, further comprising a non-volatile access control memory coupled to the processor, for storing access control data and wherein said code to provide external access to the data memory includes code to receive access request data from the interface, code to determine access permission using the stored access control data and code to provide external access to the data memory in response to the result of the determination.

16. (amended) A portable data carrier as claimed in claim 11, configured for storing supplementary data in said data memory and further comprising code to output the supplementary data from the interface in addition to the stored data, in response to an external request to read the data memory.

17. (amended) A portable data carrier as claimed in claim 11 further comprising data synthesis code to receive a first portion of data from the interface and to

combine the first portion with a second portion of data stored in the data memory and to store the result in the data memory.

18. (amended) A portable data carrier as claimed in claim 10, further comprising non-volatile communications parameter memory for storing data for accessing a communications network to receive data from the communications network for storage in the data memory.

19. (amended) A portable data carrier as claimed in claim 10, wherein the data memory is partitioned for access on a block-by-block basis, each block comprising a plurality of data bytes read or written as a set.

20. (amended) A portable data carrier as claimed in claim 10 wherein said data memory has a capacity of greater than 1 MByte, more preferably > 100 MBytes, and most preferably > 1 GByte.

21. (amended) A portable data carrier as claimed in claim 10 substantially configured as an IC card or smart card.

26. (amended) A computer system as claimed in claim 24, wherein said data access data store further comprises data item access rule data for output to the requester with said data item.

29. (amended) A computer system as claimed in claim 24, further comprising an access control data store coupled to said processor for storing access control data comprising a requester identifier, corresponding requester system access data and payment system data for identifying a payment system for use by the requester.

30. (amended) A computer system as claimed in claim 24, further comprising content synthesis code to generate substantially complete item data from partial item data provided from two or more sources.

33. (amended) A method of providing data to a data requester as claimed in claim 32 further comprising:

transmitting data access rule data to requester with the read data.

37. (amended) A data access terminal as claimed in claim 35 further comprising code to retrieve from the data supplier and output to a user stored data identifier data and associated value data and use rule data for a data item available from the data supplier.

39. (amended) A data access terminal as claimed in claim 37 further comprising code to read a stored value from the data carrier, code to compare said stored value with said value data; and code to provide a modified output to a user of one or more of said stored data identifier data, said value data and said use rule data, in response to a result of the comparison.

40. (amended) A data access terminal according to claim 35 further comprising code for user input of access control data, code to output the access control data to the data carrier, code to receive access permission data from the card, and code to output data to the user in response to the received access permission data.

42. (amended) A data access terminal according to claim 35 further comprising code to read reward data from the data carrier and to write modified reward data to the data carrier in response to said retrieval of data from the data supplier.

43. (amended) A data access terminal according to claim 35 further comprising:
code to read identity data from the data carrier;
code to transmit the identity data to the data supplier;
code to receive user characterizing data from the data supplier;
code to retrieve supplementary data in response to said characterizing data; and
code to output the supplementary data.

44. (amended) A data access terminal according to claim 35 further comprising a cash input device coupled to the processor, to provide cash input value data; and code to update payment data in the data carrier, in accordance with the cash input value data.

45. (amended) A data access terminal according to claim 35 integrated with a mobile communication device, a personal computer, an audio/video player, and/or a cable or satellite television interface device.

49. (amended) A method of providing data as claimed in claim 46, further comprising:

retrieving from the data supplier a stored data item identifier and associated value data and use rule data; and

writing use rule data for the data item into the data carrier.

50. (amended) A method of providing data as claimed in claim 48, further comprising:

reading a stored value from the data carrier;

comparing the stored value with said value data; and

outputting to a user information indicating the result of said comparing.

53. (amended) A data access device as claimed in claim 51, further comprising user access control code to input user access data, to transmit the user access data to the carrier, and to receive from the carrier user access permission data.

55. (amended) A data access device as claimed in claim 53, further comprising code to retrieve and output supplementary data to the user.

56. (amended) A data access device according to claim 51 wherein said use rules permit partial use of a data item stored on the carrier and further comprising code to write partial use status data to the data carrier when only part of a stored data item has been accessed.

57. (amended) A data access device according to claim 51 wherein the device is portable and the data carrier interface is configured for interfacing with a removable data carrier.

58. (amended) A data access device according to claim 57 configured to interface with the data carrier of claim 10.

62. (amended) A method of controlling access according to claim 59, further comprising:

inputting a user access data;

selecting the use rules dependent upon the user access data.

65. (amended) A data access system according to claim 63 further comprising a data use rule data store and wherein data use rule data is provided to the data carrier with the forwarded data for controlling user access to the forwarded data.

73. (amended) A computer program to, when running, carry out the method of claim 1.

HULST HERMEN, JR.
Application No. Not yet assigned
Page 7

PATENT

REMARKS:

Claims 1-74 are pending.

Amendment is made to eliminate all multiple dependencies from the claims, thereby avoiding the need to pay the multiple dependent surcharge.

Also attached on a separate page is an Abstract of the Disclosure.

Respectfully submitted,

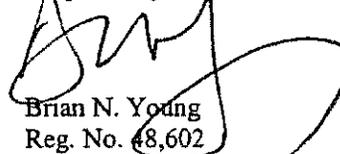

Brian N. Young
Reg. No. 48,602

TOWNSEND and TOWNSEND and CREW LLP
Two Embarcadero Center, 8th Floor
San Francisco, California 94111-3834
Tel: (415) 576-0200
Fax: (415) 576-0300
KTL/BNY/dxm
SP 1340261 v1

MARKED-UP VERSION OF THE CHANGES TO THE CLAIMS

3. (amended) A method as claimed in [claim 1 or 2] claim 1 further comprising communicating a result of the payment information validating to the data supplier.
4. (amended) A method as claimed in [any one of claims 1 to 3] claim 1 further comprising controlling access by the terminal to data from the data supplier using a control data processing system coupled to the Internet.
6. (amended) A method as claimed according to [any one of claims 1 to 5] claim 1 wherein said coupling is performed by a mobile data retrieval device comprising:
a removable data storage means;
data access means, to access downloaded data on the data storage means;
storage interface means adapted to couple the data storage and data access means;
and data output means to output data derived from the downloaded data, to a user of the device.
7. (amended) A method as claimed in [claims 1 to 6] claim 1 further comprising writing into the data storage device data relating to past use made of the downloaded data including data identifying downloaded data items; and/or data identifying data suppliers used; and/or data characterizing a user spending pattern.
8. (amended) A method as claimed in [claims 1 to 7] claim 1 wherein said portable data storage device comprises an electronic memory card or smart card.
9. (amended) A method as claimed in [any one of claims 1 to 8] claim 1 wherein the downloaded data comprises compressed audio and/or video data.
14. (amended) A portable data carrier as claimed in [claim 11, 12 or 13] claim 11, further comprising a non-volatile access control memory coupled to the processor, for storing access control data and wherein said code to provide external access to the data memory includes code to receive access request data from the interface, code to determine access

permission using the stored access control data and code to provide external access to the data memory in response to the result of the determination.

16. (amended) A portable data carrier as claimed in [any one of claims 11 to 15] claim 11, configured for storing supplementary data in said data memory and further comprising code to output the supplementary data from the interface in addition to the stored data, in response to an external request to read the data memory.

17. (amended) A portable data carrier as claimed in [any one of claims 11 to 16] claim 11 further comprising data synthesis code to receive a first portion of data from the interface and to combine the first portion with a second portion of data stored in the data memory and to store the result in the data memory.

18. (amended) A portable data carrier as claimed in [any one of claims 10 to 17] claim 10, further comprising non-volatile communications parameter memory for storing data for accessing a communications network to receive data from the communications network for storage in the data memory.

19. (amended) A portable data carrier as claimed in [any one of claims 10 to 18] claim 10, wherein the data memory is partitioned for access on a block-by-block basis, each block comprising a plurality of data bytes read or written as a set.

20. (amended) A portable data carrier as claimed in [any one of claims 10 to 19] claim 10 wherein said data memory has a capacity of greater than 1 MByte, more preferably > 100 MBytes, and most preferably > 1 GByte.

21. (amended) A portable data carrier as claimed in [any one of claims 10 to 20] claim 10 substantially configured as an IC card or smart card.

26. (amended) A computer system as claimed in [claim 24 or 25] claim 24, wherein said data access data store further comprises data item access rule data for output to the requester with said data item.

29. (amended) A computer system as claimed in [any one of claims 24 to 28] claim 24, further comprising an access control data store coupled to said processor for storing access control data comprising a requester identifier, corresponding requester system access data and payment system data for identifying a payment system for use by the requester.

30. (amended) A computer system as claimed in [any one of claims 24 to 29] claim 24, further comprising content synthesis code to generate substantially complete item data from partial item data provided from two or more sources.

33. (amended) A method of providing data to a data requester as claimed in [claim 31 or 32] claim 32 further comprising:

transmitting data access rule data to requester with the read data.

37. (amended) A data access terminal as claimed in [claim 35 or 36] claim 35 further comprising code to retrieve from the data supplier and output to a user stored data identifier data and associated value data and use rule data for a data item available from the data supplier.

39. (amended) A data access terminal as claimed in [claim 37 or 38] claim 37 further comprising code to read a stored value from the data carrier, code to compare said stored value with said value data; and code to provide a modified output to a user of one or more of said stored data identifier data, said value data and said use rule data, in response to a result of the comparison.

40. (amended) A data access terminal according to [any one of claims 35 to 39] claim 35 further comprising code for user input of access control data, code to output the access control data to the data carrier, code to receive access permission data from the card, and code to output data to the user in response to the received access permission data.

42. (amended) A data access terminal according to [any one of claims 35 to 41] claim 35 further comprising code to read reward data from the data carrier and to write modified reward data to the data carrier in response to said retrieval of data from the data supplier.

43. (amended) A data access terminal according to [any one of claims 35 to 42] claim 35 further comprising:

code to read identity data from the data carrier;
code to transmit the identity data to the data supplier;
code to receive user characterizing data from the data supplier;
code to retrieve supplementary data in response to said characterizing data; and
code to output the supplementary data.

44. (amended) A data access terminal according to [any one of claims 35 to 43] claim 35 further comprising a cash input device coupled to the processor, to provide cash input value data; and code to update payment data in the data carrier, in accordance with the cash input value data.

45. (amended) A data access terminal according to [any one of claims 35 to 44] claim 35 integrated with a mobile communication device, a personal computer, an audio/video player, and/or a cable or satellite television interface device.

49. (amended) A method of providing data as claimed in [claim 46, 47 or 48] claim 46, further comprising:

retrieving from the data supplier a stored data item identifier and associated value data and use rule data; and
writing use rule data for the data item into the data carrier.

50. (amended) A method of providing data as claimed in [claim 48 or 49] claim 48, further comprising:

reading a stored value from the data carrier;
comparing the stored value with said value data; and
outputting to a user information indicating the result of said comparing.

53. (amended) A data access device as claimed in [claim 51 or 52] claim 51, further comprising user access control code to input user access data, to transmit the user access data to the carrier, and to receive from the carrier user access permission data.

55. (amended) A data access device as claimed in [claim 53 or 54] claim 53, further comprising code to retrieve and output supplementary data to the user.

56. (amended) A data access device according to [any one of claims 51 to 55] claim 51 wherein said use rules permit partial use of a data item stored on the carrier and further comprising code to write partial use status data to the data carrier when only part of a stored data item has been accessed.

57. (amended) A data access device according to [any one of claims 51 to 56] claim 51 wherein the device is portable and the data carrier interface is configured for interfacing with a removable data carrier.

58. (amended) A data access device according to claim 57 configured to interface with the data carrier of [any one of claims 10 to 21] claim 10.

62. (amended) A method of controlling access according to [any one of claims 59 to 61] claim 59, further comprising:
inputting a user access data;
selecting the use rules dependent upon the user access data.

65. (amended) A data access system according to [claim 63 or 64] claim 63 further comprising a data use rule data store and wherein data use rule data is provided to the data carrier with the forwarded data for controlling user access to the forwarded data.

73. (amended) A computer program to, when running, carry out the method of [any preceding method claim] claim 1.

(12) INTERNATIONAL APPLICATION PUBLISHED UNDER THE PATENT COOPERATION TREATY (PCT)

(19) World Intellectual Property Organization
International Bureau



(43) International Publication Date
3 May 2001 (03.05.2001)

PCT

(10) International Publication Number
WO 01/31599 A1

(51) International Patent Classification: G07F 17/16, 7/08

Hulst [NL/GB]; 23 Tanza Road, Hampstead, London NW3 2UA (GB). RACZ, Patrick, Sandor [GB/-]; 19 Royal Square, St. Helier, Jersey JE1 4WA (GB).

(21) International Application Number: PCT/GB00/04110

(22) International Filing Date: 25 October 2000 (25.10.2000)

(74) Agent: LUCKHURST, Anthony, Henry, William; Marks & Clerk, 57-60 Lincoln's Inn Fields, London WC2A 3LS (GB).

(25) Filing Language: English

(26) Publication Language: English

(30) Priority Data:
9925227.2 25 October 1999 (25.10.1999) GB

(81) Designated States (national): AE, AG, AL, AM, AT, AU, AZ, BA, BB, BG, BR, BY, BZ, CA, CH, CN, CR, CU, CZ, DE, DK, DM, DZ, EE, ES, FI, GB, GD, GE, GH, GM, HR, HU, ID, IL, IN, IS, JP, KE, KG, KP, KR, KZ, LC, LK, LR, LS, LT, LU, LV, MA, MD, MG, MK, MN, MW, MX, MZ, NO, NZ, PL, PT, RO, RU, SD, SE, SG, SI, SK, SL, TJ, TM, TR, TT, TZ, UA, UG, US, UZ, VN, YU, ZA, ZW.

(71) Applicant (for all designated States except US): SMART-FLASH LIMITED (GB/GB); Upper Nordens, High Hurst Wood, Uckfield, East Sussex TN22 4AN (GB).

(84) Designated States (regional): ARIPO patent (GH, GM, KE, LS, MW, MZ, SD, SL, SZ, TZ, UG, ZW), Eurasian patent (AM, AZ, BY, KG, KZ, MD, RU, TJ, TM), European patent (AT, BE, CH, CY, DE, DK, ES, FI, FR, GB, GR, IE,

(72) Inventors; and

(75) Inventors/Applicants (for US only): HERMEN-ARD,

[Continued on next page]

(54) Title: DATA STORAGE AND ACCESS SYSTEMS

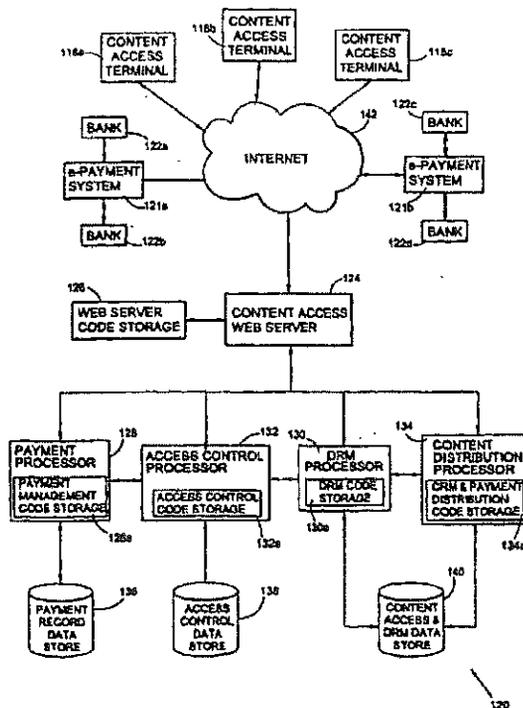

(57) Abstract: Data storage and access systems are described for downloading and paying for data such as audio and video data, text, software, games and other types of data. A portable data carrier has an interface for sending and receiving data, non-volatile data memory for storing received content data and non-volatile payment validation memory for providing payment validation data to an external device. The carrier may also store a record of access made to the stored content, and content use rules for controlling access to the stored content. Preferred embodiments store further access control data and supplementary data such as hot links to web sites and/or advertising data. A complementary data access terminal, data supply computer system and data access device are also described. The combination of payment data and stored content data and, in preferred embodiments, use rule data, helps reduce the risk of unauthorised access to data such as compressed music and video data, especially over the internet.

WO 01/31599 A1

WO 01/31599 A1

INTERNATIONAL PATENT CLASSIFICATION

IT, LU, MC, NL, PT, SE), OAPI patent (BF, BJ, CF, CG, CI, CM, GA, GN, GW, ML, MR, NE, SN, TD, TG).

For two-letter codes and other abbreviations, refer to the "Guidance Notes on Codes and Abbreviations" appearing at the beginning of each regular issue of the PCT Gazette.

Published:

— With international search report.

**This Page is Inserted by IFW Indexing and Scanning
Operations and is not part of the Official Record**

BEST AVAILABLE IMAGES

Defective images within this document are accurate representations of the original documents submitted by the applicant.

Defects in the images include but are not limited to the items checked:

- BLACK BORDERS**
- IMAGE CUT OFF AT TOP, BOTTOM OR SIDES**
- FADED TEXT OR DRAWING**
- BLURRED OR ILLEGIBLE TEXT OR DRAWING**
- SKEWED/SLANTED IMAGES**
- COLOR OR BLACK AND WHITE PHOTOGRAPHS**
- GRAY SCALE DOCUMENTS**
- LINES OR MARKS ON ORIGINAL DOCUMENT**
- REFERENCE(S) OR EXHIBIT(S) SUBMITTED ARE POOR QUALITY**
- OTHER: _____**

IMAGES ARE BEST AVAILABLE COPY.

As rescanning these documents will not correct the image problems checked, please do not report these problems to the IFW Image Problem Mailbox.

Application Data Sheet

Application Information

Application number::
Filing Date:: 01/19/06
Application Type:: Regular
Subject Matter:: Utility
Suggested classification::
Suggested Group Art Unit::
CD-ROM or CD-R??:
Number of CD disks::
Number of copies of CDs::
Sequence Submission::
Computer Readable Form (CRF)?::
Number of copies of CRF::
Title:: DATA STORAGE AND ACCESS SYSTEMS
Attorney Docket Number:: 080379-000100US
Request for Early Publication:: No
Request for Non-Publication:: No
Suggested Drawing Figure::
Total Drawing Sheets:: 17
Small Entity?:: Yes
Latin name::
Variety denomination name::
Petition included?:: No
Petition Type::
Licensed US Govt. Agency::
Contract or Grant Numbers One::
Secrecy Order in Parent Appl.:: No

Applicant Information

Applicant Authority Type:: Inventor
Primary Citizenship Country:: Netherlands
Status:: Full Capacity
Given Name:: Hermen-ard
Middle Name::
Family Name:: Hulst
Name Suffix::
City of Residence:: Amsterdam
State or Province of Residence::
Country of Residence:: Netherlands
Street of Mailing Address:: Van Tuyll van Serooskerkerweg 75hs
City of Mailing Address:: Amsterdam
State or Province of mailing address::
Country of mailing address:: Netherlands
Postal or Zip Code of mailing address:: 1076 JG

Applicant Authority Type:: Inventor
Primary Citizenship Country:: United Kingdom
Status:: Full Capacity
Given Name:: Patrick
Middle Name:: Sandor
Family Name:: Racz
Name Suffix::
City of Residence:: St. Heller
State or Province of Residence::
Country of Residence:: Jersey
Street of Mailing Address:: 19 Royal Square
City of Mailing Address:: St. Heller
State or Province of mailing address::

Country of mailing address:: Jersey
Postal or Zip Code of mailing address:: JE1 4WA

Correspondence Information

Correspondence Customer Number:: 20350

Representative Information

Representative Customer Number:: 20350

Domestic Priority Information

| | | | |
|------------------|-------------------|----------------------|----------------------|
| Application:: | Continuity Type:: | Parent Application:: | Parent Filing Date:: |
| This Application | Continuation of | 10/111,716 | 09/17/02 |

Foreign Priority Information

| | | |
|----------------|----------------------|---------------|
| Country:: | Application number:: | Filing Date:: |
| PCT | GB00/04110 | 10/25/00 |
| United Kingdom | 9925227.2 | 11/25/99 |

Assignee Information

Assignee Name:: Smart-Flash Limited
Street of mailing address:: Upper Nordens, High Hurst Wood
City of mailing address:: Uckfield
State or Province of mailing address:: East Sussex
Country of mailing address:: Great Britain
Postal or Zip Code of mailing address:: TN22 4AN

"Express Mail" Label No. EV 383391336 US
Date of Deposit January 19, 2006

I hereby certify that this is being deposited with the United States Postal Service "Express Mail Post Office to Addressee" service under 37 CFR 1.10 on the date indicated above and is addressed to:

Commissioner for Patents
P.O. Box 1450
Alexandria, VA 22313-1450

By:

Dana Kane

PATENT
Attorney Docket No.: 080379-000100US
Client Reference No.: F/USP81421X
Con.

IN THE UNITED STATES PATENT AND TRADEMARK OFFICE

In re application of:

Hermen-ard HULST and Patrick
Sandor RACZ

Application No.:

Filed: January 19, 2006

For: DATA STORAGE AND ACCESS
SYSTEMS

Examiner:

Art Unit:

INFORMATION DISCLOSURE
STATEMENT UNDER 37 CFR §1.97 and
§1.98

Commissioner for Patents
P.O. Box 1450
Alexandria, VA 22313-1450

Sir:

The references cited on attached form PTO/SB/08A and PTO/SB/08B are being called to the attention of the Examiner. In accordance with 37 CFR §1.98(d), copies of the references can be found in Application No. 09/697,534, filed October 25, 2000 (Attorney Docket No. 080528-000000US) and in parent application 10/111,716, filed September 17, 2000 (Attorney Docket No. 080379-000000US). Copies of the Information Disclosure Statement filed with parent application 10/111,716 on April 25, 2002 and the Supplemental Information Disclosure Statement filed therein on January 16, 2004.

BEST AVAILABLE COPY

Herman-ard HULST
January 19, 2006
Page 2

PATENT

It is respectfully requested that the cited references be expressly considered during the prosecution of this application, and the references be made of record therein and appear among the "references cited" on any patent to issue therefrom.

Also enclosed is a copy of the Search/Examination report corresponding to the priority PCT application GB00/04110.

As provided for by 37 CFR §1.97(g) and (h), no inference should be made that the information and references cited are prior art merely because they are in this statement and no representation is being made that a search has been conducted or that this statement encompasses all the possible relevant information.

Applicant believes that no fee is required for submission of this statement. However, if a fee is required, the Commissioner is authorized to deduct such fee from the undersigned's Deposit Account No. 20-1430. Please deduct any additional fees from, or credit any overpayment to, the above-noted Deposit Account.

Respectfully submitted,

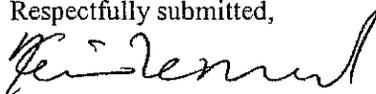

Kevin T. LeMond
Reg. No. 35,933

TOWNSEND and TOWNSEND and CREW LLP
Two Embarcadero Center, Eighth Floor
San Francisco, California 94111-3834
Tel: 415-576-0200
Fax: 415-576-0300
KTL:dk
60682925 v1

I hereby certify that this correspondence is being deposited with the United States Postal Service as first class mail in an envelope addressed to:

PATENT
Attorney Docket No.: 080379-000000US
Client Reference No.: F/USP81421X

Commissioner for Patents
P.O. Box 1450
Alexandria, VA 22313-1450

On January 16, 2004

TOWNSEND and TOWNSEND and CREW LLP

By Mark T. Davis

IN THE UNITED STATES PATENT AND TRADEMARK OFFICE

In re application of:

HULST HERMEN-ARD

Application No.: 10/111,716

Filed: September 17, 2002

For: DATA STORAGE AND ACCESS
SYSTEMS

Examiner: Paik, Steve S.

Art Unit: 2876

SUPPLEMENTAL INFORMATION
DISCLOSURE STATEMENT UNDER 37
CFR §1.97 and §1.98

Commissioner for Patents
P.O. Box 1450
Alexandria, VA 22313-1450

Sir:

The references cited on attached form PTO/SB/08A are being called to the attention of the Examiner. In accordance with 37 CFR §1.98(d), copies of the references can be found in Application No. 09/697,534, filed October 25, 2000 (Attorney Docket No. 080528-000000US). It is respectfully requested that the cited references be expressly considered during the prosecution of this application, and the references be made of record therein and appear among the "references cited" on any patent to issue therefrom.

As provided for by 37 CFR 1.97(g) and (h), no inference should be made that the information and references cited are prior art merely because they are in this statement and no

representation is being made that a search has been conducted or that this statement encompasses all the possible relevant information.

Applicant believes that no fee is required for submission of this statement.

However, if a fee is required, the Commissioner is authorized to deduct such fee from the undersigned's Deposit Account No. 20-1430. Please deduct any additional fees from, or credit any overpayment to, the above-noted Deposit Account.

Respectfully submitted,

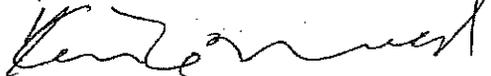

Kevin T. LeMond
Reg. No. 35,933

TOWNSEND and TOWNSEND and CREW LLP
Two Embarcadero Center, Eighth Floor
San Francisco, California 94111-3834
Tel: 415-576-0200
Fax: 415-576-0300
KTL:mtd
60113553 v1

| | | | | |
|---|---|--------------------------|------------------------|-----------------|
| Substitute for form 1449A/PTO | | Complete If Known | | |
| INFORMATION DISCLOSURE STATEMENT BY APPLICANT (use as many sheets as necessary) | | Application Number | 10/111,716 | |
| | | Filing Date | September 17, 2002 | |
| | | First Named Inventor | Hulst, Hermen-Ard | |
| | | Art Unit | 2876 | |
| | | Examiner Name | Paik, Steve S. | |
| Sheet | 1 | of | Attorney Docket Number | 080379-000000US |

| U.S. PATENT DOCUMENTS+ | | | | | | |
|------------------------|--------------------------|-----------------|-----------------------------------|--------------------------------|--|---|
| Examiner Initials* | Cite No. ¹ | Document Number | | Publication Date MM-DD-YYYY | Name of Patentee or Applicant of Cited Document | Pages, Columns, Lines, Where Relevant Passages or Relevant Figures Appear |
| | | Number | Kind Code ² (if known) | | | |
| | AA | US 5,226,145 | | 07/08/1993 | Moronaga et al. | |
| | AB | US 5,367,150 | | 11/22/1994 | Kitta et al. | |
| | AC | US 5,457,748 | | 10/10/1995 | Dolphin | |
| | AD | US 5,588,146 | | 12/24/1996 | Leroux | |
| | AE | US 5,677,853 | | 10/14/1997 | Dolphin | |
| | AF | US 5,703,851 | | 12/30/1997 | Dolphin | |
| | AG | US 5,754,654 | | 05/19/1998 | Hiroya et al. | |
| | AH | US 5,784,202 | | 06/11/1998 | Kim | |
| | AI | US 5,809,241 | | 09/15/1998 | Hanel et al. | |
| | AJ | US 5,847,372 | | 12/08/1998 | Kreft | |
| | AK | US 5,889,860 | | 03/30/1999 | Eiler et al. | |
| | AL | US 5,901,330 | | 11/04/1999 | Sun et al. | |
| | AM | US 5,918,213 | | 06/29/1999 | Bernard et al. | |
| | AN | US 5,923,884 | | 07/13/1999 | Peyret et al. | |
| | AO | US 6,012,634 | | 01/11/2000 | Brogan et al. | |
| | AP | US 6,078,917 | | 06/20/2000 | Pautsen et al. | |
| | AQ | US 6,119,845 | | 09/19/2000 | Muller et al. | |
| | AR | US-6,202,056 | | 03/13/2001 | Nuttall | |
| | AS | US-6,385,731 | | 05/07/2002 | Ananda | |
| | AT | US 6,424,975 | | 07/23/2002 | Walter et al. | |
| | AU | US 6,442,570 | | 08/27/2002 | Wu | |
| | AV | US 6,473,829 | | 10/29/2002 | Dahman et al. | |
| | AW | US 6,510,236 | | 01/21/2003 | Crane et al. | |
| | AX | US-6,553,413 | | 04/22/2003 | Leighton et al. | |
| | AY | US-6,574,643 | | 06/03/2003 | Walter et al. | |

| FOREIGN PATENT DOCUMENTS | | | | | | | | |
|--------------------------|--------------------------|---------------------------|---------------------|-----------------------------------|--------------------------------|---|--|--------------------------|
| Examiner Initials* | Cite No. ¹ | Foreign Patent Document | | | Publication Date MM-DD-YYYY | Name of Patentee or Applicant of Cited Document | Pages, Columns, Lines, Where Relevant Passages or Relevant Figures Appear | T ⁶ |
| | | Country Code ³ | Number ⁴ | Kind Code ⁵ (if known) | | | | |
| | AZ | WO | 98/19237 | | 05/07/1998 | | | <input type="checkbox"/> |
| | BA | WO | 98/33343 | | 07/30/1998 | | | <input type="checkbox"/> |
| | BB | WO | 98/37526 | | 08/27/1998 | | | <input type="checkbox"/> |
| | BC | EP | 0195098 | | 10/03/1990 | | | <input type="checkbox"/> |
| | BD | EP | 0713198 | | 05/22/1996 | | | <input type="checkbox"/> |
| | BE | EP | 0823694 | | 02/11/1998 | | | <input type="checkbox"/> |
| | BF | EP | 0542298 | | 04/22/1998 | | | <input type="checkbox"/> |
| | BG | EP | 0843449 | | 05/07/1998 | | | <input type="checkbox"/> |
| | BH | EP | 0914001 | | 05/06/1999 | | | <input type="checkbox"/> |

| | | | |
|-----------------------|--|--------------------|--|
| Examiner Signature | | Date Considered | |
|-----------------------|--|--------------------|--|

*EXAMINER: Initial if reference considered, whether or not citation is in conformance with MPEP 609. Draw line through citation if not in conformance and not considered. Include copy of this form with next communication to applicant. ¹ Applicant's unique citation designation number (optional). ² Kind Codes of U.S. Patent Documents at www.uspto.gov or MPEP 901.04. ³ Enter Office that issued the document, by the two-letter code (WIPO Standard ST.3). ⁴ For Japanese patent documents, the indication of the year of the reign of the Emperor must precede the serial number of the patent document. ⁵ Kind of document by the appropriate symbols as indicated on the document under WIPO Standard ST. 16 if possible. ⁶ Applicant is to place a check mark here if English language Translation is attached.
60113553 v1

IN THE UNITED STATES PATENT AND TRADEMARK OFFICE

In re application of:

HULST HERMEN-ARD

Application No.:

Filed: Herewith

For: DATA STORAGE AND ACCESS
SYSTEMS

Examiner: Unassigned

Art Unit: Unassigned

INFORMATION DISCLOSURE
STATEMENT UNDER 37 CFR §1.97 and
§1.98

San Francisco, CA 94111
April 25, 2002

Assistant Commissioner for Patents
Washington, D.C. 20231

Sir:

The references cited on attached form PTO/SB/08A and PTO/SB/08B are being called to the attention of the Examiner. Copies of the references are enclosed. It is respectfully requested that the cited references be expressly considered during the prosecution of this application, and the references be made of record therein and appear among the "references cited" on any patent to issue therefrom.

As provided for by 37 CFR 1.97(g) and (h), no inference should be made that the information and references cited are prior art merely because they are in this statement and no representation is being made that a search has been conducted or that this statement encompasses all the possible relevant information.

HULST HERMEN-ARD
Application No.: Unassigned
Page 2

PATENT

Applicant believes that no fee is required for submission of this statement, since it is being submitted prior to the first Office Action. However, if a fee is required, the Commissioner is authorized to deduct such fee from the undersigned's Deposit Account No. 20-1430. Please deduct any additional fees from, or credit any overpayment to, the above-noted Deposit Account.

Respectfully submitted,

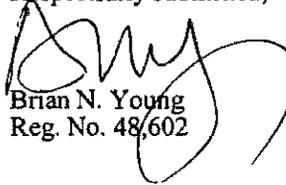

Brian N. Young
Reg. No. 48,602

TOWNSEND and TOWNSEND and CREW LLP
Two Embarcadero Center, 8th Floor
San Francisco, California 94111-3834
Tel: 415-576-0200
Fax: 415-576-0300
KTL/BNY/dxm

SF 1340359 v1

| FOREIGN PATENT DOCUMENTS | | | | | | | | |
|--------------------------|-----------------------|---------------------------|---------------------|-----------------------------------|--------------------------------|---|---|----------------|
| Examiner Initials* | Cite No. ¹ | Foreign Patent Document | | | Publication Date MM-DD-YYYY | Name of Patentee or Applicant of Cited Document | Pages, Columns, Lines, Where Relevant Passages or Relevant Figures Appear | T ⁶ |
| | | Country Code ² | Number ⁴ | Kind Code ³ (if known) | | | | |
| | AA | EP | 0713198 | A2 | 05/22/1998 | | | |
| | AB | EP | 0823694 | A1 | 02/11/1998 | | | |
| | AC | EP | 0843449 | A2 | 05/20/1998 | | | |
| | AD | EP | 0914001 | A1 | 05/06/1999 | | | |
| | AE | WIPO | WO 98/19237 | A1 | 05/07/1998 | | | |
| | AF | | | | | | | |
| | AG | | | | | | | |
| | AH | | | | | | | |

| | | | |
|--------------------|--|-----------------|--|
| Examiner Signature | | Date Considered | |
|--------------------|--|-----------------|--|

*EXAMINER: Initial if reference considered, whether or not citation is in conformance with MPEP 609. Draw line through citation if not in conformance and not considered. Include copy of this form with next communication to applicant.

¹ Applicant's unique citation designation number (optional). ² Applicant is to place a check mark here if English language Translation is attached.

Burden Hour Statement: This form is estimated to take 2.0 hours to complete. Time will vary depending upon the needs of the individual case. Any comments on the amount of time you are required to complete this form should be sent to the Chief Information Officer, U.S. Patent and Trademark Office, Washington, DC 20231. DO NOT SEND FEES OR COMPLETED FORMS TO THIS ADDRESS. SEND TO: Assistant Commissioner for Patents, Washington, DC 20231.

SF 1340359 v1

**This Page is Inserted by IFW Indexing and Scanning
Operations and is not part of the Official Record**

BEST AVAILABLE IMAGES

Defective images within this document are accurate representations of the original documents submitted by the applicant.

Defects in the images include but are not limited to the items checked:

- BLACK BORDERS**
- IMAGE CUT OFF AT TOP, BOTTOM OR SIDES**
- FADED TEXT OR DRAWING**
- BLURRED OR ILLEGIBLE TEXT OR DRAWING**
- SKEWED/SLANTED IMAGES**
- COLOR OR BLACK AND WHITE PHOTOGRAPHS**
- GRAY SCALE DOCUMENTS**
- LINES OR MARKS ON ORIGINAL DOCUMENT**
- REFERENCE(S) OR EXHIBIT(S) SUBMITTED ARE POOR QUALITY**
- OTHER: _____**

IMAGES ARE BEST AVAILABLE COPY.

As rescanning these documents will not correct the image problems checked, please do not report these problems to the IFW Image Problem Mailbox.

Under the Paperwork Reduction Act of 1995, no persons are required to respond to a collection of information unless it displays a valid OMB control number.

| PATENT APPLICATION FEE DETERMINATION RECORD | | | | | Application or Docket Number | | | | | | |
|---|--|--------------|------------------------------------|---------------|------------------------------|--------------|---------------------|----|-------------------------|-------------------------|---------------------|
| Substitute for Form PTO-875 | | | | | 11,336,758 | | | | | | |
| APPLICATION AS FILED – PART I | | | | | SMALL ENTITY | | OR | | OTHER THAN SMALL ENTITY | | |
| (Column 1) | | (Column 2) | | | RATE (\$) | FEE (\$) | | | RATE (\$) | FEE (\$) | |
| FOR | NUMBER FILED | NUMBER EXTRA | | | | 150 | | | | 300 | |
| BASIC FEE (37 CFR 1.16(a), (b), or (c)) | | | | | | | | | | | |
| SEARCH FEE (37 CFR 1.16(k), (l), or (m)) | | | | | | 250 | | | | 500 | |
| EXAMINATION FEE (37 CFR 1.16(o), (p), or (q)) | | | | | | 100 | | | | 200 | |
| TOTAL CLAIMS (37 CFR 1.16(i)) | 74 | minus 20 = | | 54 | XS 25 | 1350 | | | XS50 | | |
| INDEPENDENT CLAIMS (37 CFR 1.16(h)) | 16 | minus 3 = | | 13 | XS100 | 1300 | | | XS200 | | |
| APPLICATION SIZE FEE (37 CFR 1.16(s)) | If the specification and drawings exceed 100 sheets of paper, the application size fee due is \$250 (\$125 for small entity) for each additional 50 sheets or fraction thereof. See 35 U.S.C. 41(a)(1)(G) and 37 CFR | | | | | | | | | | |
| MULTIPLE DEPENDENT CLAIM PRESENT (37 CFR 1.16(j)) | | | | | 180 | 3150 | | | 360 | | |
| | | | | | TOTAL | | | | | | |
| * If the difference in column 1 is less than zero, enter "0" in column 2. | | | | | | | | | | | |
| APPLICATION AS AMENDED – PART II | | | | | SMALL ENTITY | | OR | | OTHER THAN SMALL ENTITY | | |
| (Column 1) | | (Column 2) | | (Column 3) | | RATE (\$) | ADDITIONAL FEE (\$) | | | RATE (\$) | ADDITIONAL FEE (\$) |
| AMENDMENT A | CLAIMS REMAINING AFTER AMENDMENT | | HIGHEST NUMBER PREVIOUSLY PAID FOR | PRESENT EXTRA | | | | | | | |
| | Total (37 CFR 1.16(i)) | * | Minus | ** | = | X = | | | | X = | |
| | Independent (37 CFR 1.16(h)) | * | Minus | *** | = | X = | | | | X = | |
| | Application Size Fee (37 CFR 1.16(s)) | | | | | | | | | | |
| | FIRST PRESENTATION OF MULTIPLE DEPENDENT CLAIM (37 CFR 1.16(j)) | | | | | 180 | | | | 360 | |
| | | | | | TOTAL | | | | TOTAL | | |
| | | | | | ADD'T FEE | | | | ADD'T FEE | | |
| | | | | | | | | | | | |
| (Column 1) | | (Column 2) | | (Column 3) | | SMALL ENTITY | | OR | | OTHER THAN SMALL ENTITY | |
| AMENDMENT B | CLAIMS REMAINING AFTER AMENDMENT | | HIGHEST NUMBER PREVIOUSLY PAID FOR | PRESENT EXTRA | | RATE (\$) | ADDITIONAL FEE (\$) | | | RATE (\$) | ADDITIONAL FEE (\$) |
| | Total (37 CFR 1.16(i)) | * | Minus | ** | = | X = | | | | X = | |
| | Independent (37 CFR 1.16(h)) | * | Minus | *** | = | X = | | | | X = | |
| | Application Size Fee (37 CFR 1.16(s)) | | | | | | | | | | |
| | FIRST PRESENTATION OF MULTIPLE DEPENDENT CLAIM (37 CFR 1.16(j)) | | | | | N/A | | | | N/A | |
| | | | | | TOTAL | | | | TOTAL | | |
| | | | | | ADD'T FEE | | | | ADD'T FEE | | |
| | | | | | | | | | | | |
| * If the entry in column 1 is less than the entry in column 2, write "0" in column 3. | | | | | | | | | | | |
| ** If the "Highest Number Previously Paid For" IN THIS SPACE is less than 20, enter "20". | | | | | | | | | | | |
| *** If the "Highest Number Previously Paid For" IN THIS SPACE is less than 3, enter "3". | | | | | | | | | | | |
| The "Highest Number Previously Paid For" (Total or Independent) is the highest number found in the appropriate box in column 1. | | | | | | | | | | | |

This collection of information is required by 37 CFR 1.16. The information is required to obtain or retain a benefit by the public which is to file (and by the USPTO to process) an application. Confidentiality is governed by 35 U.S.C. 122 and 37 CFR 1.14. This collection is estimated to take 12 minutes to complete, including gathering, preparing, and submitting the completed application form to the USPTO. Time will vary depending upon the individual case. Any comments on the amount of time you require to complete this form and/or suggestions for reducing this burden, should be sent to the Chief Information Officer, U.S. Patent and Trademark Office, U.S. Department of Commerce, P.O. Box 1450, Alexandria, VA 22313-1450. DO NOT SEND FEES OR COMPLETED FORMS TO THIS ADDRESS. SEND TO: Commissioner for Patents, P.O. Box 1450, Alexandria, VA 22313-1450.

If you need assistance in completing the form, call 1-800-PTO-9199 and select option 2.

BEST AVAILABLE COPY

PATENT APPLICATION SERIAL NO 11,336,758

U.S. DEPARTMENT OF COMMERCE
PATENT AND TRADEMARK OFFICE
FEE RECORD SHEET

01/25/2006 MWLD6E1 00000089 201430 11336758

| | |
|------------|------------|
| 01 FC:2011 | 150.00 DA |
| 02 FC:2111 | 250.00 DA |
| 03 FC:2311 | 100.00 DA |
| 04 FC:2201 | 1100.00 DA |
| 05 FC:2202 | 1350.00 DA |

03/02/2006 EVD111 00000001 201430 11336758

01 FC:2201 200.00 DA

PTO-1556

(5/87)