



[54] METHOD, APPARATUS, SYSTEM AND FIRMWARE FOR SECURE TRANSACTIONS

[75] Inventors: Stephen M. Curry, Dallas; Donald W. Loomis, Coppell; Christopher W. Fox, Dallas, all of Tex.

[73] Assignee: Dallas Semiconductor Corporation, Dallas, Tex.

[21] Appl. No.: 09/041,190

[22] Filed: Mar. 10, 1998

Related U.S. Application Data

[63] Continuation of application No. 08/594,983, Jan. 31, 1996, Pat. No. 5,748,740.

[60] Provisional application No. 60/004,510, Sep. 29, 1995.

[51] Int. Cl.<sup>7</sup> ..... H04L 9/00; H04L 9/30

[52] U.S. Cl. .... 705/65; 235/379; 380/30; 705/75; 713/156; 713/173; 713/174

[58] Field of Search ..... 380/4, 9, 21, 23, 380/24, 25, 30, 46, 49, 50; 235/379, 380; 705/64, 65, 66, 67, 68, 69, 75; 713/155, 156, 157, 158, 168, 172, 173, 174

[56] References Cited

U.S. PATENT DOCUMENTS

4,731,842	3/1988	Smith	380/24
5,577,120	11/1996	Penzias	380/23
5,748,740	5/1998	Curry et al.	380/25

FOREIGN PATENT DOCUMENTS

0172670A2	2/1986	European Pat. Off. .
0186981A2	7/1986	European Pat. Off. .
0194839A2	9/1986	European Pat. Off. .
0294248A1	12/1988	European Pat. Off. .
0337185A2	10/1989	European Pat. Off. .
045806A2	11/1991	European Pat. Off. .
0624014A2	11/1994	European Pat. Off. .
4406602A1	9/1995	Germany .
WO93/08545	4/1993	WIPO .

OTHER PUBLICATIONS

Federal Information Processing Standards Publication, (FIPS PUB) 186, *Digital Signatur Standard (DDS)*, Issued: May 19, 1994.

Federal Information Processing Standards Publication, (FIPS PUB) 190-1, *Secure Hash Standard*, Issued: May 31, 1994.

Microsoft Corporation's Secure Transaction Technology, *STT Wire Formats and Protoc* version 0.902, Oct. 5, 1995. Matonis, Jon W., *Digital Cash and Monetary Freedom*, <http://www.info.isoc.org/HMP/PAPER/136/html/paper.html>, as of Apr. 1995.

MasterCard, *Secure Electronic Payment Protocol*, Draft Version 1.1, Sep. 29, 1995.

MasterCard, *Secure Electronic Payment Protocol, Part 2; Functional Specifications*, Draft Version 1.1, Sep. 29, 1995.

MasterCard, *Secure Electronic Payment Protocol, Part 3; Payment System Specification*, Draft Version 1.1, Sep. 29, 1995.

MasterCard, *Secure Electronic Payment Protocol, Part 4; Certificate Management Specification*, Draft Version 1.1, Sep. 29, 1995.

SGS-Thomson Microelectronics, *CMOS Crypto-Computer Family*, Advance Datasheet ST16xF74, Oct., 1993.

SGS-Thomson Microelectronics, *CMOS MCU Based Safeguarded Smartcard IC with Modular Arithmetic Processor*, Advanced Data Sheet, ST16CF54, Sep. 1994.

Micro Card, *CP8® Products Crypto Card*, Jan. 25, 1995. Wayner, Peter, *Digital Ca\$h, Commerce on the Net*, Chpt. 3 & 10 and Appendix B, Jun. 1995.

Schneier, Bruce, *Applied Cryptography*, Chpt. 19, pp. 461-482, 1996.

Primary Examiner—Bernarr E. Gregory  
Attorney, Agent, or Firm—Jenkins & Gilchrist

[57] ABSTRACT

The present invention relates to an electronic module used for secure transactions. More specifically, the electronic module is capable of passing information back and forth between a service provider's equipment via a secure, encrypted technique so that money and other valuable data can be securely passed electronically. The module is capable of being programmed, keeping track of real time, recording transactions for later review, and creating encryption key pairs.

16 Claims, 8 Drawing Sheets

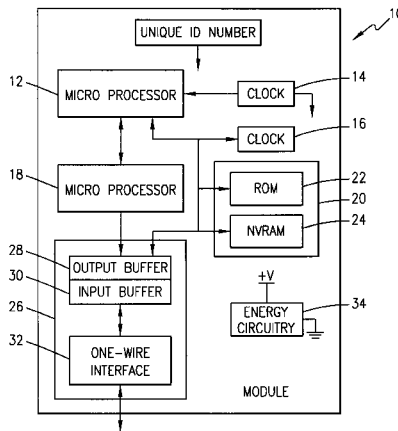

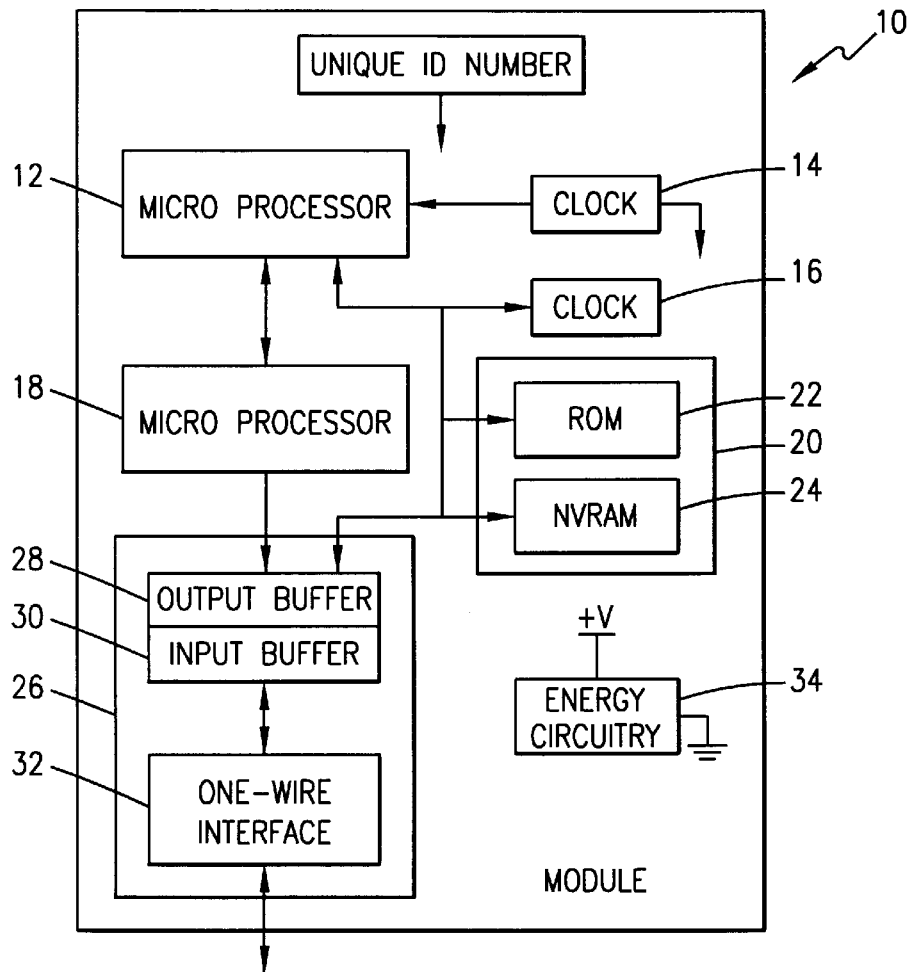

FIG. 1

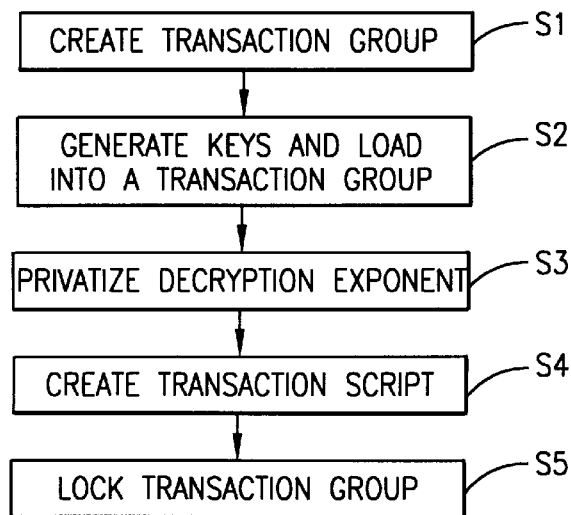

FIG. 2

FIG. 3

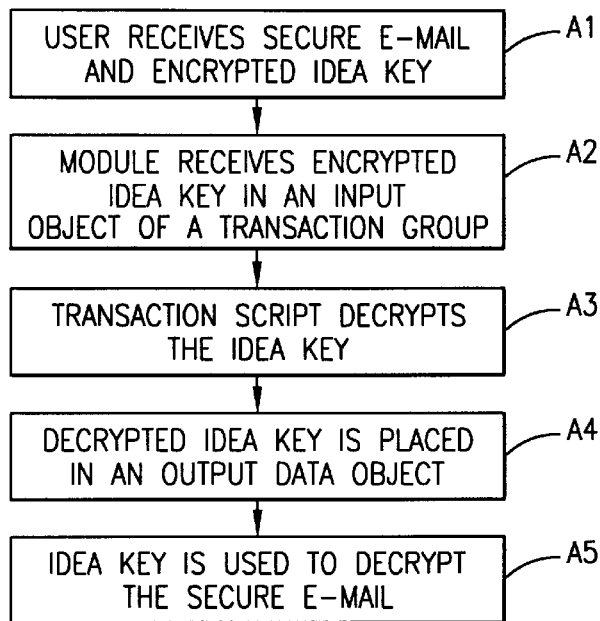
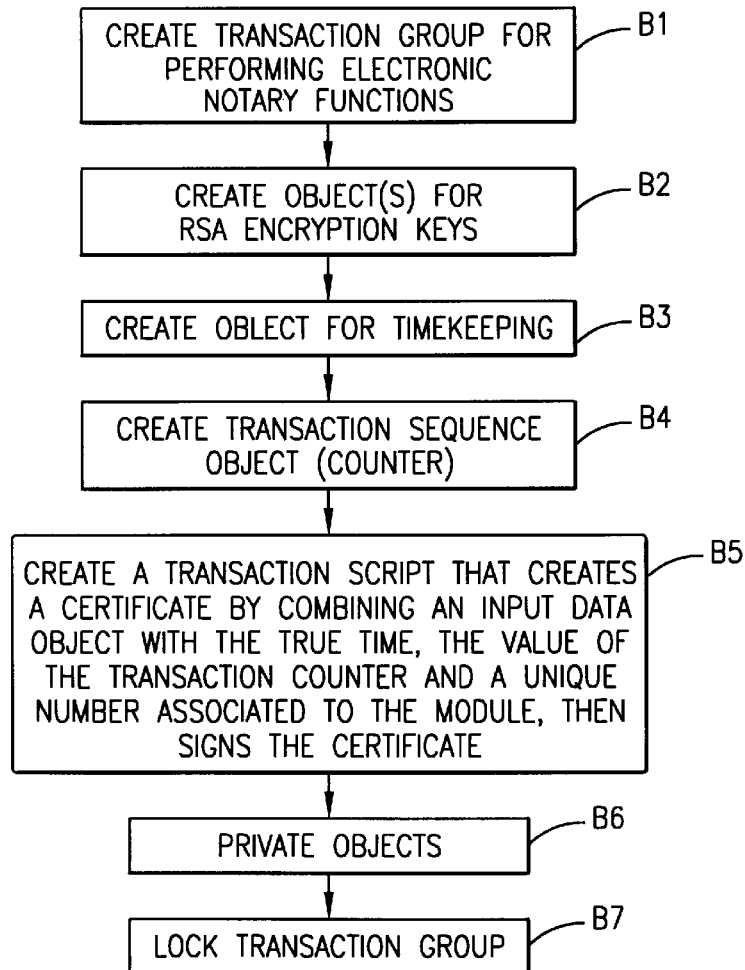

FIG. 4



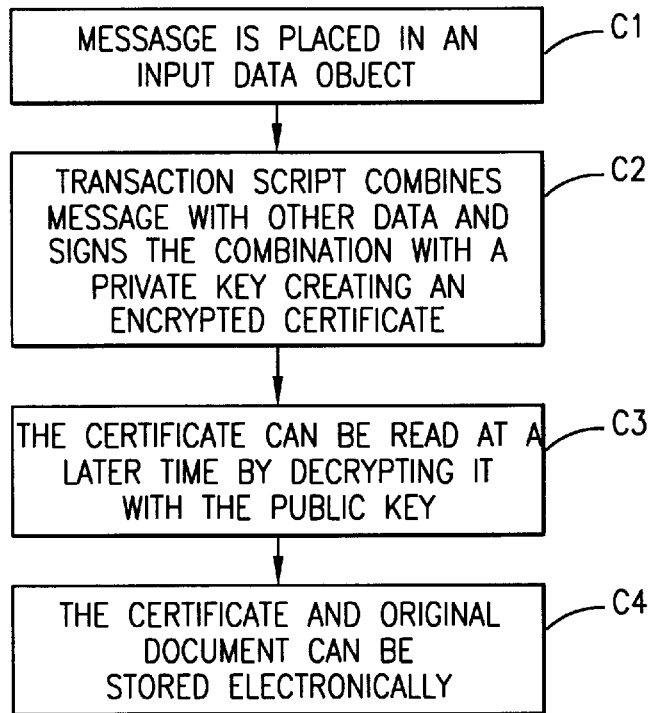

FIG. 5

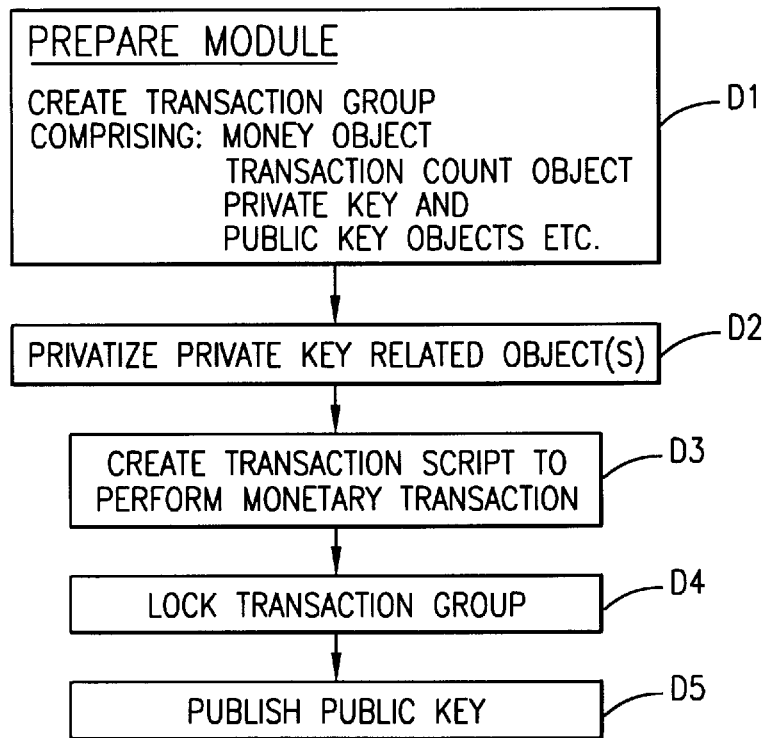

FIG. 6

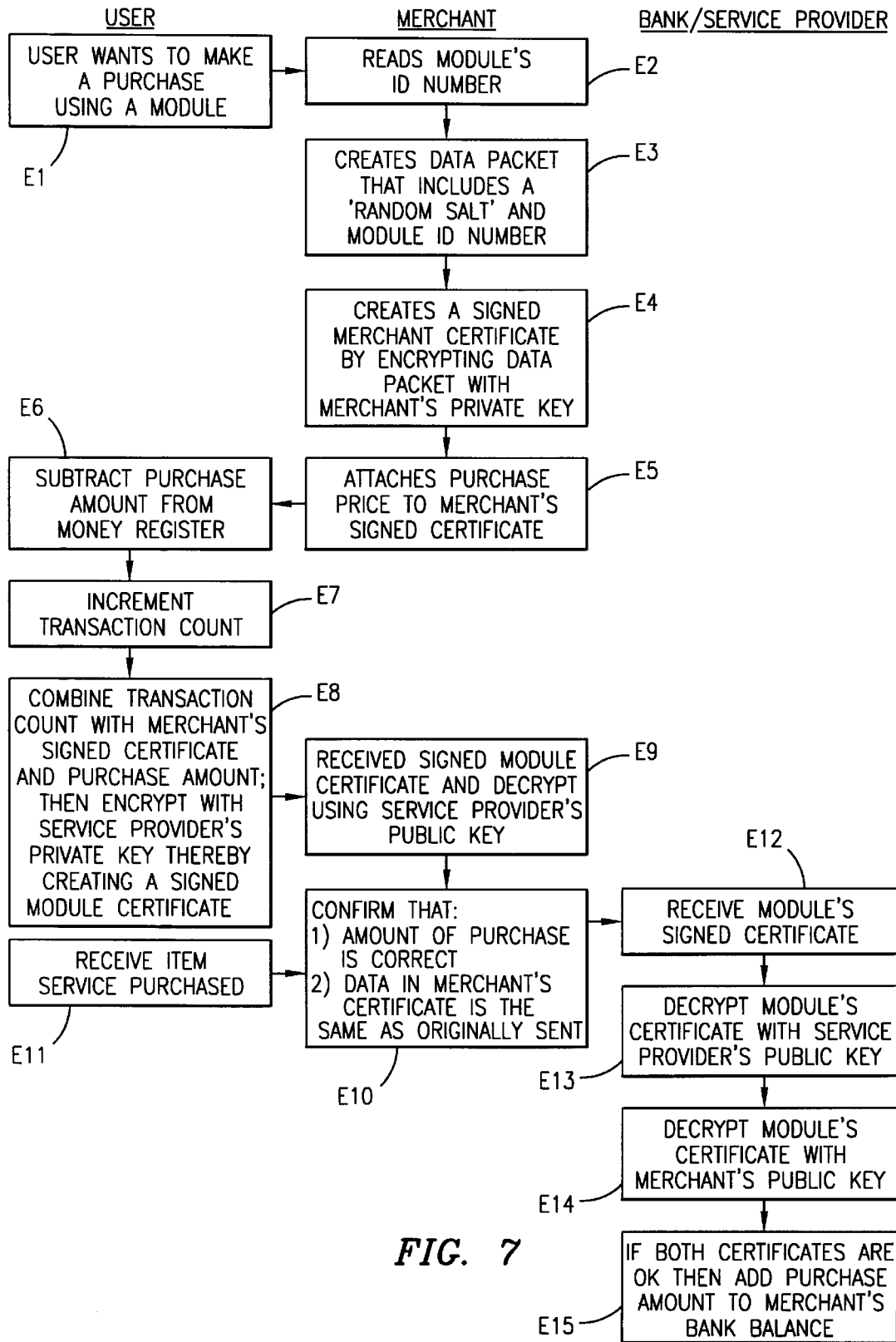

FIG. 7

# Explore Litigation Insights

Docket Alarm provides insights to develop a more informed litigation strategy and the peace of mind of knowing you're on top of things.

## Real-Time Litigation Alerts



Keep your litigation team up-to-date with **real-time alerts** and advanced team management tools built for the enterprise, all while greatly reducing PACER spend.

Our comprehensive service means we can handle Federal, State, and Administrative courts across the country.

## Advanced Docket Research



With over 230 million records, Docket Alarm's cloud-native docket research platform finds what other services can't. Coverage includes Federal, State, plus PTAB, TTAB, ITC and NLRB decisions, all in one place.

Identify arguments that have been successful in the past with full text, pinpoint searching. Link to case law cited within any court document via Fastcase.

## Analytics At Your Fingertips



Learn what happened the last time a particular judge, opposing counsel or company faced cases similar to yours.

Advanced out-of-the-box PTAB and TTAB analytics are always at your fingertips.

## API

Docket Alarm offers a powerful API (application programming interface) to developers that want to integrate case filings into their apps.

## LAW FIRMS

Build custom dashboards for your attorneys and clients with live data direct from the court.

Automate many repetitive legal tasks like conflict checks, document management, and marketing.

## FINANCIAL INSTITUTIONS

Litigation and bankruptcy checks for companies and debtors.

## E-DISCOVERY AND LEGAL VENDORS

Sync your system to PACER to automate legal marketing.