

Petitioner Apple Inc.'s Presentation
Covered Business Method Review Of
Patent Owner's U.S. Patent
Nos. 5,191,573 And 5,966,440

May 6, 2014

CBM2013-00020 and CBM2013-00023

Patent Trial and Appeal Board
United States Patent and Trademark Office

'573 And '440 Patents – Claim 1

1. A method for transmitting a desired digital audio signal stored on a first memory of a first party to a second memory of a second party comprising the steps of:

transferring money electronically via a telecommunication lien [sic] to the first party at a location remote from the second memory and controlling use of the first memory from the second party financially distinct from the first party, said second party controlling use and in possession of the second memory;

connecting electronically via a telecommunications line the first memory with the second memory such that the desired digital audio signal can pass there-between;

transmitting the desired digital audio signal from the first memory with a transmitter in control and possession of the first party to a receiver having the second memory at a location determined by the second party, said receiver in possession and control of the second party; and

storing the digital signal in the second memory.

Ex. 4101/4304 ('573 Patent), Claim 1.

1. A method for transferring desired digital video or digital audio signals comprising the steps of:

forming a connection through telecommunications lines between a first memory of a first party and a second memory of a second party control unit of a second party, said first memory having said desired digital video or digital audio signals;

selling electronically by the first party to the second party through telecommunications lines, the desired digital video or digital audio signals in the first memory, *the second party is at a second party location and the step of selling electronically includes the step of charging a fee via telecommunications lines by the first party to the second party at a first party location remote from the second party location, the second party has an account and the step of charging a fee includes the step of charging the account of the second party;* and

transferring the desired digital video or digital audio signals from the first memory of the first party to the second memory of the second party control unit of the second party through telecommunications lines while the second party control unit with the second memory is in possession and control of the second party; storing the desired digital video or digital audio signals in a non-volatile storage portion the second memory; and

playing through speakers of the second party control unit the digital video or digital audio signals stored in the second memory, said speakers of the second party control unit connected with the second memory of the second party control unit;

wherein the non-volatile storage portion is not a tape or CD.

Ex. 4301 ('440 Patent), Claim 1.

'573 And '440 Patents – Figure 1

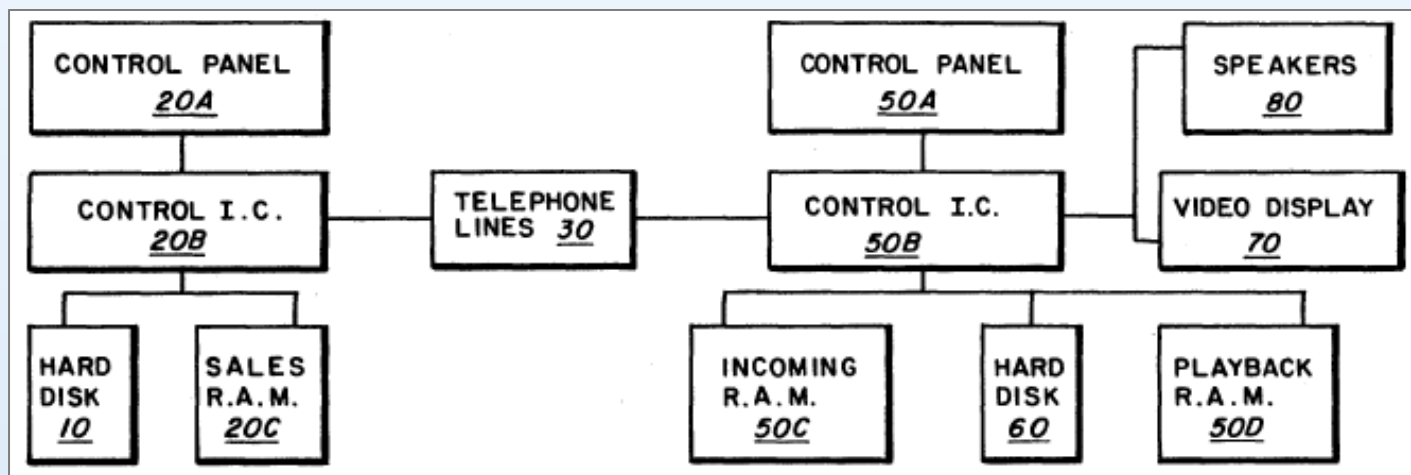

Ex. 4101/4304 ('573 Patent) Figure 1.

“[T]he applicant’s method in no manner necessitates the need for a receiver which is controlled by the controller of the transmitter. Any suitable recording apparatus controlled and in possession of the second party can be used to record the incoming digital signals. Accordingly, the second party’s own stereo system can be coupled to the incoming signals for recording. In this manner, the second party is not limited to a predesigned receiver of the first party controlling the transmitter”

Ex. 4102/4305 ('573 Patent File History) at 140-141.

“Patent Owner does not dispute that the *components* needed to practice the claims were available prior to 1988”

Patent Owner Response, CBM2013-00020 (Paper No. 41, Jan. 3, 2014) at 31 (emphasis original);
CBM2013-00023 (Paper No. 38, Jan. 3, 2014) at 34 (emphasis original).

'573 And '440 Patents – Claim 1

1. A method for transmitting a desired digital audio signal stored on a first memory of a first party to a second memory of a second party comprising the steps of:

transferring money electronically via a telecommunication lien [sic] to the first party at a location remote from the second memory and controlling use of the first memory from the second party financially distinct from the first party, said second party controlling use and in possession of the second memory;

connecting electronically via a telecommunications line the first memory with the second memory such that the desired digital audio signal can pass there-between;

transmitting the desired digital audio signal from the first memory with a transmitter in control and possession of the first party to a receiver having the second memory at a location determined by the second party, said receiver in possession and control of the second party; and

storing the digital signal in the second memory.

Ex. 4101/4304 ('573 Patent), Claim 1.

1. A method for transferring desired digital video or digital audio signals comprising the steps of:

forming a connection through telecommunications lines between a first memory of a first party and a second memory of a second party control unit of a second party, said first memory having said desired digital video or digital audio signals;

selling electronically by the first party to the second party through telecommunications lines, the desired digital video or digital audio signals in the first memory, *the second party is at a second party location and the step of selling electronically includes the step of charging a fee via telecommunications lines by the first party to the second party at a first party location remote from the second party location, the second party has an account and the step of charging a fee includes the step of charging the account of the second party;* and

transferring the desired digital video or digital audio signals from the first memory of the first party to the second memory of the second party control unit of the second party through telecommunications lines while the second party control unit with the second memory is in possession and control of the second party; storing the desired digital video or digital audio signals in a non-volatile storage portion the second memory; and

playing through speakers of the second party control unit the digital video or digital audio signals stored in the second memory, said speakers of the second party control unit connected with the second memory of the second party control unit;

wherein the non-volatile storage portion is not a tape or CD.

Ex. 4301 ('440 Patent), Claim 1.

Examples Of Prior Art Statements About Electronic Sale Of Downloaded Music/Video

“At a recent press demonstration hosted by AT&T at its headquarters here, CompuSonics made use of AT&T’s land-based telephone data transmission system to digitally transmit and receive music between Chicago and New York.”

Ex. 4106/4309 (“Joint Telerecording Push: CompuSonics, AT&T Link,” *Billboard*, Oct. 5, 1985) at 3.

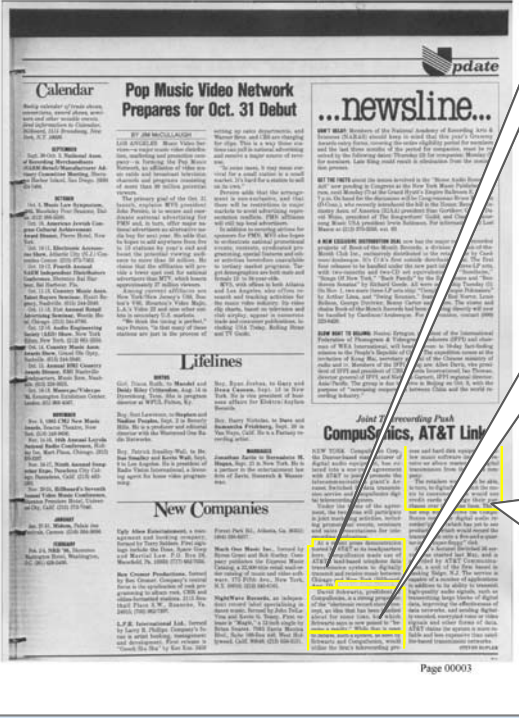

“David Schwartz, president of CompuSonics, is a strong proponent of the ‘electronic record store’ concept, an idea that has been bandied about for some time, but which Schwartz says is now poised to ‘become a reality.’”

Ex. 4106/4309 (“Joint Telerecording Push: CompuSonics, AT&T Link,” *Billboard*, Oct. 5, 1985) at 3.

“[S]uch a system, as seen by Schwartz and CompuSonics, would utilize the firm’s telerecording process and hard disk equipment to allow music software dealers to receive an album master via a digital transmission from the record company. The retailers would then be able, in turn, to digitally transmit the music to consumers who would use credit cards to charge their purchases over the phone lines.”

Ex. 4106/4309 (“Joint Telerecording Push: CompuSonics, AT&T Link,” *Billboard*, Oct. 5, 1985) at 3.

Explore Litigation Insights

Docket Alarm provides insights to develop a more informed litigation strategy and the peace of mind of knowing you're on top of things.

Real-Time Litigation Alerts



Keep your litigation team up-to-date with **real-time alerts** and advanced team management tools built for the enterprise, all while greatly reducing PACER spend.

Our comprehensive service means we can handle Federal, State, and Administrative courts across the country.

Advanced Docket Research



With over 230 million records, Docket Alarm's cloud-native docket research platform finds what other services can't. Coverage includes Federal, State, plus PTAB, TTAB, ITC and NLRB decisions, all in one place.

Identify arguments that have been successful in the past with full text, pinpoint searching. Link to case law cited within any court document via Fastcase.

Analytics At Your Fingertips



Learn what happened the last time a particular judge, opposing counsel or company faced cases similar to yours.

Advanced out-of-the-box PTAB and TTAB analytics are always at your fingertips.

API

Docket Alarm offers a powerful API (application programming interface) to developers that want to integrate case filings into their apps.

LAW FIRMS

Build custom dashboards for your attorneys and clients with live data direct from the court.

Automate many repetitive legal tasks like conflict checks, document management, and marketing.

FINANCIAL INSTITUTIONS

Litigation and bankruptcy checks for companies and debtors.

E-DISCOVERY AND LEGAL VENDORS

Sync your system to PACER to automate legal marketing.