



US007007062B1

(12) **United States Patent**
Serenyi et al.

(10) **Patent No.:** **US 7,007,062 B1**
(45) **Date of Patent:** **Feb. 28, 2006**

(54) **METHODS AND APPARATUSES FOR TRANSFERRING DATA**

WO WO 00/27087 A1 5/2000

OTHER PUBLICATIONS

(75) Inventors: **Denis Serenyi**, Menlo Park, CA (US);
Chris LeCroy, Mountain View, CA (US)

Carsten Griwodz, Alex Jonas, Michael Zink, "Affordable Infrastructure for Stream Playback in the Internet", Darmstadt University of Industrial Process and System Communications (KOM), Dec. 12, 1999, Technical Report TR-KOM-1999-07, Darmstadt, Germany, (pp. 1-17).

(73) Assignee: **Apple Computer, Inc.**, Cupertino, CA (US)

Henning Schulzrinne, Jonathan Rosenberg, "Internet Telephony: architecture and protocols—an IETF perspective," Computer Networks, Elsevier Science Publishers: Amsterdam, NL, vol. 31 No. 3, Feb. 11, 1999 (pp. 237-255).

(*) Notice: Subject to any disclaimer, the term of this patent is extended or adjusted under 35 U.S.C. 154(b) by 970 days.

(21) Appl. No.: **09/757,235**

(Continued)

(22) Filed: **Jan. 8, 2001**

Primary Examiner—Robert B. Harrell
(74) *Attorney, Agent, or Firm*—Blakely, Sokoloff, Taylor & Zafman LLP

Related U.S. Application Data

(63) Continuation-in-part of application No. 09/603,108, filed on Jun. 22, 2000.

(57) **ABSTRACT**

(51) **Int. Cl.**
G06F 13/00 (2006.01)
(52) **U.S. Cl.** **709/203**
(58) **Field of Classification Search** 705/14;
709/231, 203
See application file for complete search history.

The present invention provides several methods and apparatuses for transmitting multimedia data using streaming media protocols such as real-time transfer protocols (RTP) and real-time streaming protocols (RTSP) in a computer network environment. A request for RTP data is sent from the caching proxy server to the server. The request may be for one specific type of data or multiple unrelated types of data. The server responds to the request indicating its support for the requested data. The caching proxy server determines whether to proceed or terminate the data transmission process based on the response provided by the server. If it is determined to proceed with the data transmission process, the caching proxy informs the server to send the requested data. The server sends the requested data in a body of a RTP packet. The RTP packet uses a RTP Meta-Info payload format, which includes a body and a field header. The field header includes fields to identify the streaming media data, and the field body includes the requested streaming media data.

(56) **References Cited**

U.S. PATENT DOCUMENTS

5,918,020 A	6/1999	Blackard et al.	
6,263,371 B1	7/2001	Geagan, III et al.	
6,275,471 B1	8/2001	Bushmitch et al.	
6,415,327 B1	7/2002	Beckerman et al.	
6,505,169 B1 *	1/2003	Bhagavath et al.	705/14
6,546,421 B1	4/2003	Wynblatt et al.	
6,625,258 B1	9/2003	Ram et al.	
6,629,138 B1	9/2003	Lambert et al.	
6,708,213 B1	3/2004	Bommaiah et al.	
6,771,644 B1	8/2004	Brassil et al.	

FOREIGN PATENT DOCUMENTS

WO WO 97/22201 A2 6/1997

19 Claims, 15 Drawing Sheets

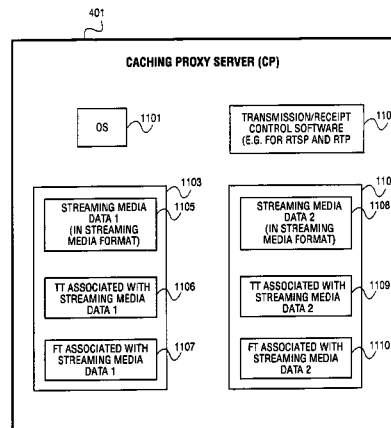

OTHER PUBLICATIONS

Henning Schulzrinne, et al. "RTP: A transport protocol for real-time applications," Network Working Group RFC 1889 RTP, Jan. 1996 (pp. 1-75).

PCT International Search Report for PCT Int'l Appln No. US01/20044, mailed May 22, 2002 (8 pages).

* cited by examiner

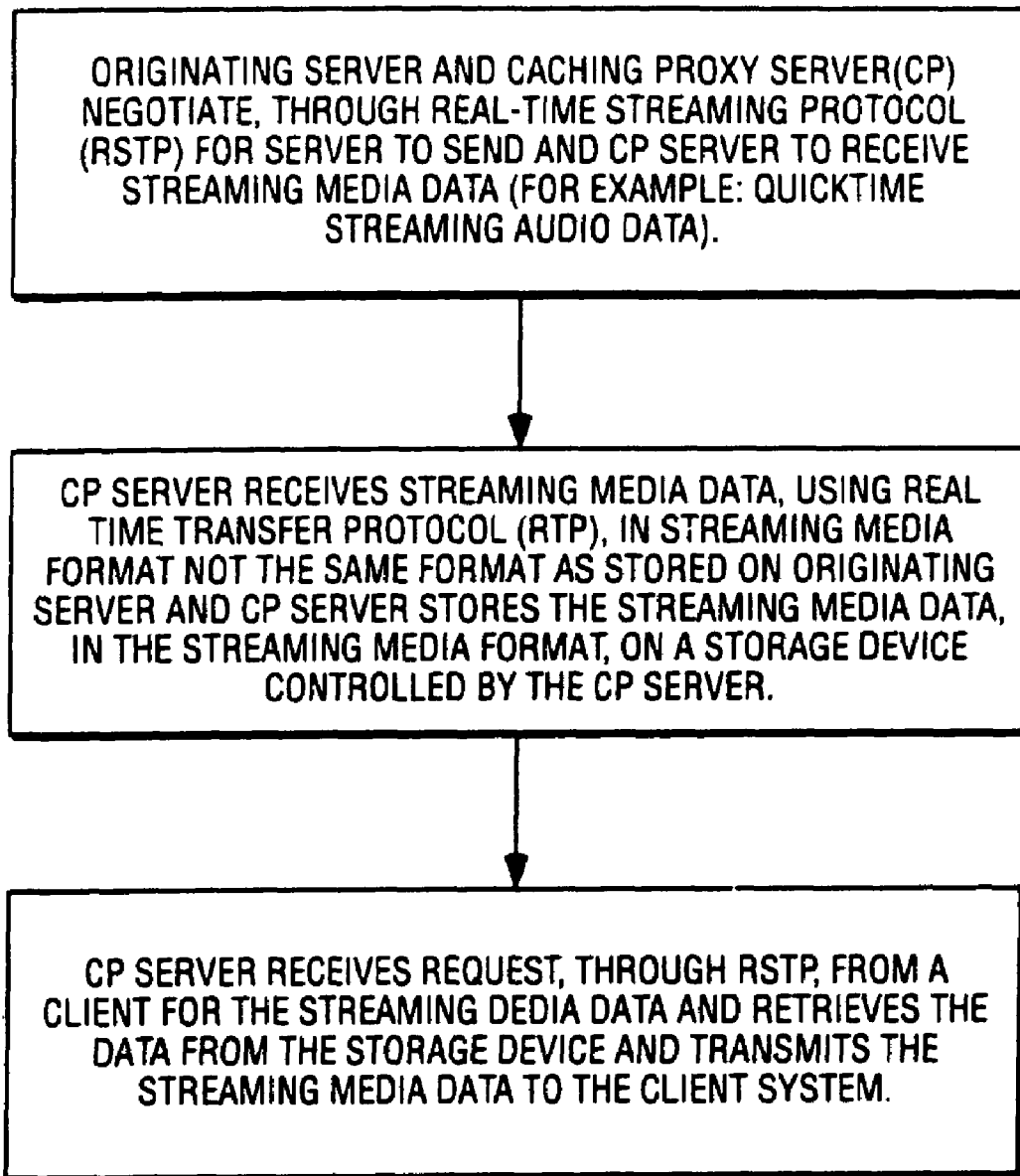

FIG. 1A
(Prior Art)

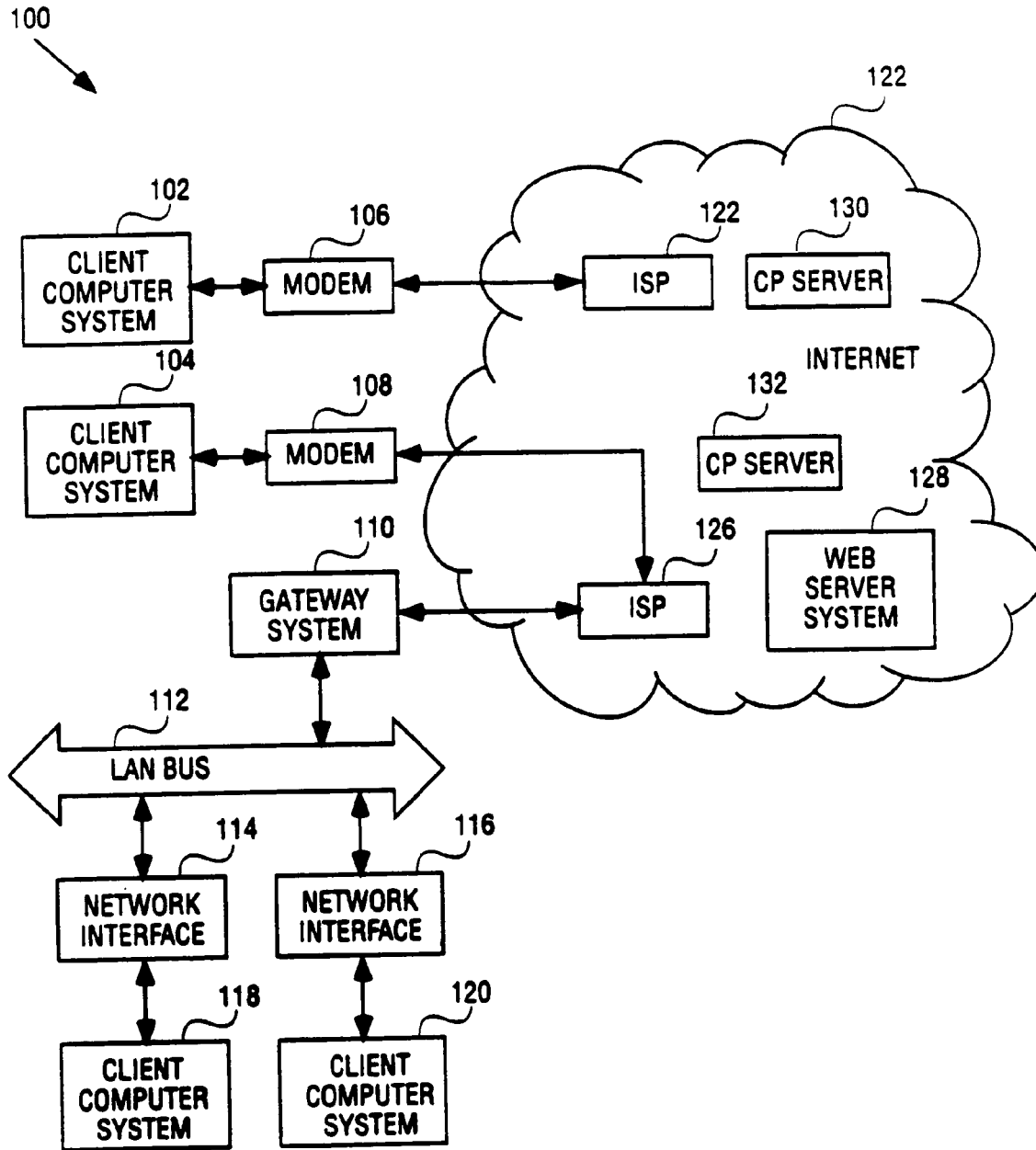

FIG. 1B

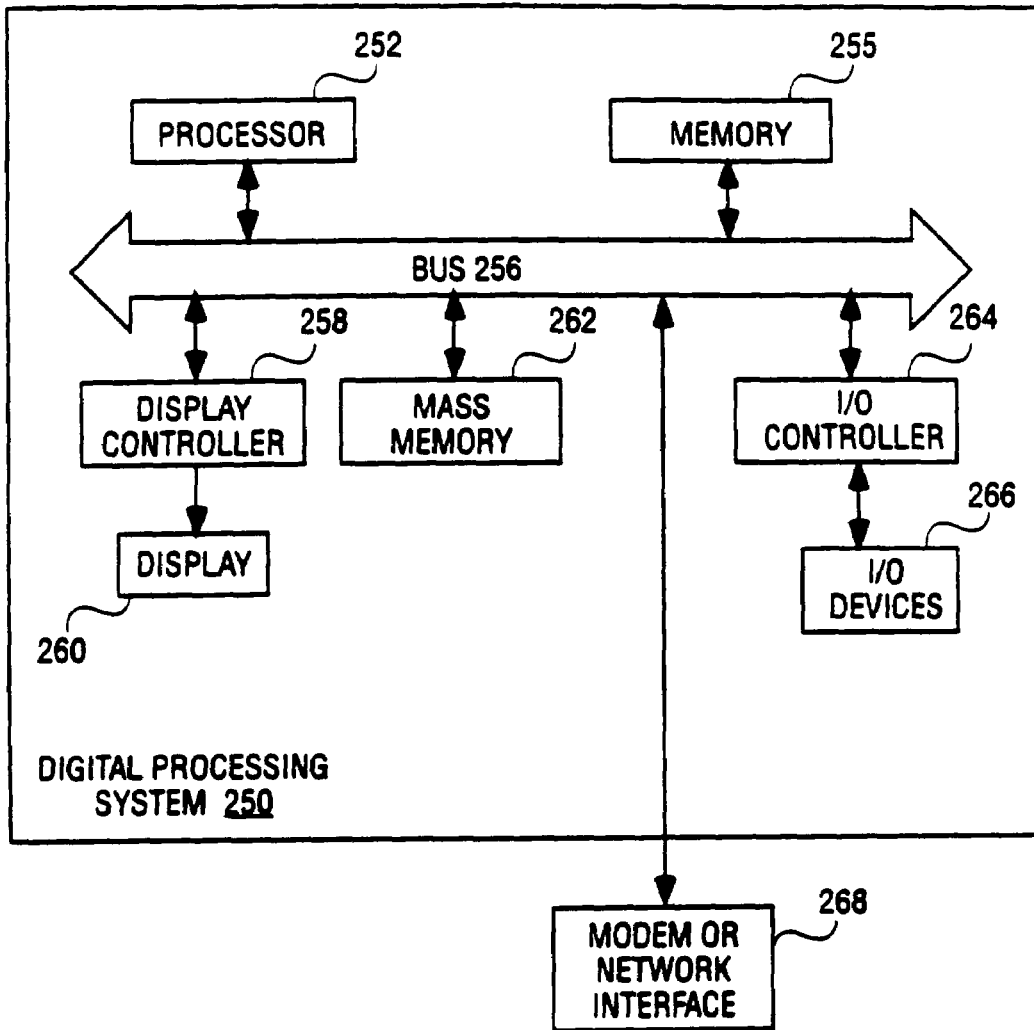

FIG. 2

Explore Litigation Insights

Docket Alarm provides insights to develop a more informed litigation strategy and the peace of mind of knowing you're on top of things.

Real-Time Litigation Alerts



Keep your litigation team up-to-date with **real-time alerts** and advanced team management tools built for the enterprise, all while greatly reducing PACER spend.

Our comprehensive service means we can handle Federal, State, and Administrative courts across the country.

Advanced Docket Research



With over 230 million records, Docket Alarm's cloud-native docket research platform finds what other services can't. Coverage includes Federal, State, plus PTAB, TTAB, ITC and NLRB decisions, all in one place.

Identify arguments that have been successful in the past with full text, pinpoint searching. Link to case law cited within any court document via Fastcase.

Analytics At Your Fingertips



Learn what happened the last time a particular judge, opposing counsel or company faced cases similar to yours.

Advanced out-of-the-box PTAB and TTAB analytics are always at your fingertips.

API

Docket Alarm offers a powerful API (application programming interface) to developers that want to integrate case filings into their apps.

LAW FIRMS

Build custom dashboards for your attorneys and clients with live data direct from the court.

Automate many repetitive legal tasks like conflict checks, document management, and marketing.

FINANCIAL INSTITUTIONS

Litigation and bankruptcy checks for companies and debtors.

E-DISCOVERY AND LEGAL VENDORS

Sync your system to PACER to automate legal marketing.