

station via an uplink, information representative of the trigger event and recording response information generated by the control station.

In accordance with yet another aspect of the present invention, the method comprises steps of generating calculated data elements and derived data elements from the raw data elements, and accumulating the calculated and
5 derived data elements in a recording device.

The present invention will use information acquired from the vehicle to more accurately assess vehicle usage and thereby derive insurance costs more precisely and fairly. Examples of possible actuarial classes
10 developed from vehicle provided data include:

Driver:

Total driving time in minutes by each driver of the insured vehicle;
number of minutes driving in high/low risk locations (high/low accident
15 areas);
number of minutes of driving at high/low risk times (rush hour or Sunday afternoon);
safe driving behavior,
using seat belts,
20 use of turn signals,
observance of speed limits, and
observance of traffic control devices;
number of sudden braking situations; and
number of sudden acceleration situations.

25 **Vehicle:**

Location vehicle is parked at night (in garage, in driveway, on street);
and
location vehicle is parked at work (high theft locations, etc.).

These new and more precise actuarial classes are considered to be better predictors of loss because they are based on actual use of the vehicle and the behaviors demonstrated by the driver. This will allow the consumers unprecedented control over the ultimate cost of their vehicle insurance.

5 In accordance with the present invention, additional discounts and surcharges based on data provided by the insured vehicle will be available. Examples of surcharges and discounts based on vehicle provided data include:

Surcharges:

10 Excessive hard braking situations occurring in high risk locations; and intermittent use of a safety device, such as seat belts.

Discounts:

Regular selection of low/high risk routes of travel;
regular travel at low/high risk times;
15 significant changes in driving behavior that results in a lower risk;
vacation discount when the vehicle is not used;
regular use of safety devices; and
unfailing observance of speed limits.

20 There is some overlap between the use of actuarial classes and discounts and surcharges. Until data has been gathered and analyzed it is not possible to determine which vehicle provided data will be used to determine actuarial classes and which will be used for surcharges or discounts.

25 One benefit obtained by use of the present invention is a system that will provide precise and timely information about the current operation of an insured motor vehicle that will enable an accurate determination of operating characteristics, including such features as miles driven, time of use and speed of the vehicle. This information can be used to establish actual usage based insurance charges, eliminating rating errors that are prevalent in traditional

systems and will result in vehicle insurance charges that can be directly controlled by individual operators.

5 It is another benefit of the subject invention that conventional motor vehicle electronics are easily supplemented by system components comprising a data recording, a navigation system and a communications device to extract selected insurance relevant data from the motor vehicle.

10 It is yet another object of the present invention to generate actuarial classes and operator profiles relative thereto based upon actual driving characteristics of the vehicle and driver, as represented by the monitored and recorded data elements for providing a more knowledgeable, enhanced insurance rating precision.

15 The subject new insurance rating system retrospectively adjusts and prospectively sets premiums based on data derived from motor vehicle operational characteristics and driver behavior through the generation of new actuarial classes determined from such characteristics and behavior, which classes heretofore have been unknown in the insurance industry. The invention comprises an integrated system to extract via multiple sensors, screen, aggregate and apply for insurance rating purposes, data generated by the actual operation of the specific vehicle and the insured user/driver.

20 Other benefits and advantages of the subject new vehicle insurance cost determination process will become apparent to those skilled in the art upon a reading and understanding of the specification.

Brief Description of the Drawings

25 The invention may take physical form in certain parts and steps and arrangements of parts and steps, the preferred embodiments of which will be described in detail in this specification and illustrated in the accompanying drawings which form a part hereof and wherein:

- 10 -

FIGURE 1 is a flowchart generally describing a data gathering process from a vehicle;

FIGURE 2 is a flowchart detailing the gathering and consolidating of appropriate information for determining a cost of insurance and the resulting insurance billing process;

FIGURE 3 is a suggestive perspective drawing of a vehicle including certain data element monitoring, recording and communicating devices;

FIGURE 4 is a block diagram of a vehicle on-board computer and recording system implementing the subject invention for selective communication with a central control center and a global positioning navigation system;

FIGURE 5 is a flowchart generally illustrating a method for acquiring and recording vehicle insurance related data; and

FIGURE 6 is a tabular illustration of various sources of insurance-related data, a necessary interface for acquiring the data and an exemplary sample rate therefor.

Detailed Description of the Invention

Referring now to the drawings, wherein the showings are for purposes of illustrating the preferred embodiments of the invention only and not for purposes of limiting same, the FIGURES show an apparatus and method for monitoring, recording and communicating insurance related data for determination of an accurate cost of insurance based upon evidence relevant to the actual operation and in particular the relative safety of that operation.

Generally, a vehicle user is charged for insurance based upon statistical averages related to the safety of operation based upon the insurer's experience with other users who drive similar vehicles in a similar geographic area. The invention allows for the measure of the actual data while the motor vehicle is being driven. Such data measurement will allow the vehicle user to directly control

- 11 -

his/her insurance costs by operating the vehicle in a manner which he/she will know will evidence superior safety of operation and a minimal risk of generation of an insurance claim. Examples of data which can be monitored and recorded include:

5

1. Actual miles driven;
2. Types of roads driven on (high risk vs. low risk); and,
3. Safe operation of the vehicle by the vehicle user through:
 - A. speeds driven,
 - 10 B. safety equipment used, such as seat belt and turn signals,
 - C. time of day driven (high congestion vs. low congestion),
 - D. rate of acceleration,
 - 15 E. rate of braking,
 - F. observation of traffic signs.

With reference to FIGURE 3, an exemplary motor vehicle is shown in which the necessary apparatus for implementing the subject invention is included. An on-board computer 300 monitors and records various sensors and operator actions to acquire the desired data for determining a fair cost of insurance. Although not shown therein, a plurality of operating sensors are associated with the motor vehicle to monitor a wide variety of raw data elements. Such data elements are communicated to the computer through a connections cable which is operatively connected to the vehicle data bus 304 through an SAE-J1978 connector, or OBD-II connector or other vehicle sensors 306. A driver input device 308 is also operatively connected to the computer 300 through connector 307 and cable 302. The computer is powered through the car battery 310 or a conventional generator system (not shown). Tracking of

20

25

the vehicle for location identification can be implemented by the computer 300 through navigation signals obtained from a GPS (global positioning system) antenna or other locating system 312. The communications link to a central control station is accomplished through the cellular telephone, radio, satellite or other wireless communication system 314.

FIGURE 4 provides the block diagram of the in-vehicle computer system. The computer 300 is comprised of four principal components, an on-board data storage device 402, an input/output subsystem 404 for communicating to a variety of external devices, a central processing unit and memory device 406 and a real time operating kernel 408 for controlling the various processing steps of the computer 300. The computer 300 essentially communicates with three on-board vehicle devices for acquisition of information representative of various actual vehicle operating characteristics. A driver input console 410 allows the driver to input data representative of a need for assistance or for satisfaction of various threshold factors which need to be satisfied before the vehicle can be operated. The physical operation of the vehicle is monitored through various sensors 412 in operative connection with the vehicle data bus, while additional sensors 414 not normally connected to the data bus can be in direct communication with the computer 300 as will hereinafter be more fully explained.

The vehicle is linked to an operation control center 416 by a communications link 418, preferably comprising a conventional cellular telephone interconnection. A navigation sub-system 420 receives radio navigation signals from a GPS 422.

The type of elements monitored and recorded by the subject invention comprise raw data elements, calculated data elements and derived data elements. These can be broken down as follows:

Raw Data Elements:

Power train sensors

5 RPM,
transmission setting (Park, Drive, Gear, Neutral),
throttle position,
engine coolant temperature,
intake air temperature,
barometric pressure;

Electrical sensors

10 brake light on,
turn signal indicator,
headlamps on,
hazard lights on,
back-up lights on,
15 parking lights on,
wipers on,
doors locked,
key in ignition,
key in door lock,
20 horn applied;

Body sensors

airbag deployment,
ABS application,
level of fuel in tank,
25 brakes applied,
radio station tuned in,
seat belt on,
door open,
tail gate open,

odometer reading,
cruise control engaged,
anti-theft disable;

Other sensors

5 vehicle speed,
 vehicle location,
 date,
 time,
 vehicle direction,
10 IVHS data sources.

Calculated Data Elements:

 rapid deceleration;
 rapid acceleration;
 vehicle in skid;
15 wheels in spin;
 closing speed on vehicle in front;
 closing speed of vehicle in rear;
 closing speed of vehicle to side (right or left);
 space to side of vehicle occupied;
20 space to rear of vehicle occupied;
 space to front of vehicle occupied;
 lateral acceleration;
 sudden rotation of vehicle;
 sudden loss of tire pressure;
25 driver identification (through voice recognition or code or fingerprint
 recognition);
 distance travelled; and
 environmental hazard conditions (e.g. icing, etc.).

Derived Data Elements:

- vehicle speed in excess of speed limit;
- observation of traffic signals and signs;
- road conditions;
- 5 traffic conditions; and
- vehicle position.

This list includes many, but not all, potential data elements.

With particular reference to **FIGURE 1**, a flowchart generally illustrating the data gathering process of the subject invention is illustrated.

10 Such a process can be implemented with conventional computer programming in the real time operating kernel **408** of the computer **300**. The process is identified with initially a begin step **100** (key in ignition?) and a check of whether the vehicle is operating at step **102**. If the vehicle is not operating a reverification occurs every two (2) minutes as shown at step **104**. It should be

15 noted that the computer is continually powered by at least the vehicle battery **310** (**FIGURE 3**), but it can be appreciated that during operation the generator (not shown) will supply the energy. If the vehicle is operating, then there is a step of recording sensor information **106**. The recording comprises monitoring a plurality of raw data elements, calculated data elements and derived data

20 elements as identified above. Each of these is representative of an operating state of the vehicle or an action of the operator. Select ones of the plurality of data elements are recorded when the ones are determined to have an identified relationship to the safety standards. For example, vehicle speed in excess of a predetermined speed limit will need to be recorded but speeds below the limit

25 need only be monitored and stored on a periodic basis. The recording may be made in combination with date, time and location. Other examples of data needed to be recorded are excessive rates of acceleration or frequent hard braking.

- 16 -

The recording process would be practically implemented by monitoring and storing the data in a buffer for a selected period of time, e.g., thirty seconds. Periodically, such as every two minutes, the status of all monitored sensors for the data elements is written to a file which is stored in the vehicle data storage 402. The raw, calculated and derived data elements listed above comprise some of the data elements to be so stored.

Certain of the recorded sensor information may comprise a trigger event of which inquiry is identified at step 108. "Trigger events" are defined as a combination of sensor data requiring additional action or which may result in a surcharge or discount during the insurance billing process. Certain trigger events may require immediate upload 110 to a central control which will then be required to take appropriate action. For example, a trigger event would be rapid deceleration in combination with airbag deployment indicating a collision, in which case the system could notify the central control of the vehicle location. Alternatively, if the operator were to trigger on an emergency light, similarly the system could notify the central control of the vehicle location indicating that an emergency is occurring. The trigger information is recorded, as at step 116, and whatever response is taken by the central control is also recorded at step 118. The trigger information recording step 116 and the recording sensor information step 106 may impart recording of information in the on-board data storage device 402 or memory 406. The event response information recording at step 118 will usually occur in the central control station. Such response information could be the dispatch of an emergency vehicle, or the telephoning of police or an EMS unit.

Trigger events are divided into two groups: those requiring immediate action and those not requiring immediate action, but necessary for proper billing of insurance. Those required for proper billing of insurance will be recorded in the same file with all the other recorded vehicle sensor information. Those trigger events requiring action will be uploaded to a central

control center which can take action depending on the trigger event. Some trigger events will require dispatch of emergency services, such as police or EMS, and others will require the dispatch of claims representatives from the insurance company.

5 The following comprises an exemplary of some, but not all, trigger events:

Need for Assistance:

These events would require immediate notification of the central control center.

- 10 1. Accident Occurrence. An accident could be determined through the use of a single sensor, such as the deployment of an airbag. It could also be determined through the combination of sensors, such as a sudden deceleration of the vehicle without the application of the brakes.
- 15 2. Roadside assistance needed. This could be through the pressing of a "panic button" in the vehicle or through the reading of a sensor, such as the level of fuel in the tank. Another example would be loss of tire pressure, signifying a flat tire.
- 20 3. Lock-out assistance needed. The reading of a combination of sensors would indicate that the doors are locked but the keys are in the ignition and the driver has exited the vehicle.
- 25 4. Driving restrictions. The insured can identify circumstances in which he/she wants to be notified of driving within restricted areas, and warned when he/she is entering a dangerous area. This could be applied to youthful drivers where the parent wants to restrict time or place of driving, and have a record thereof.

Unsafe Operation of the Vehicle

These events would be recorded in the in-vehicle recording device for future upload. Constant trigger events would result in notification of the driver of the exceptions.

1. Excessive speed. The reading of the vehicle speed sensors would indicate the vehicle is exceeding the speed limit. Time would also be measured to determine if the behavior is prolonged.
2. Presence of alcohol. Using an air content analyzer or breath analyzer, the level of alcohol and its use by the driver could be determined.
3. Non-use of seatbelt. Percent of sample of this sensor could result in additional discount for high use or surcharge for low or no use.
4. Non-use of turn signals. Low use could result in surcharge.
5. ABS application without an accident. High use could indicate unsafe driving and be subject to a surcharge.

With particular reference to FIGURE 2, a general flowchart describing the steps of the gathering of appropriate information for billing insurance on a periodic basis is illustrated.

At the initiation of the vehicle insurance billing process, the central billing system of the insurer will acquire 202 the vehicle sensor record file from the sensor record file 204 from each vehicle to be billed. This process of data acquisition will involve a periodic uploading of the vehicle file 204. This file will be uploaded to the central system when the storage device 402 in the vehicle approaches capacity, on command, or when the billing process starts. All the information from the combination of files stored in the vehicle will be used to determine the bill for the insurance on the vehicle for the prior insurance period. Data acquisition is also made from the trigger event response file 206 in the acquisition step 208. This data is stored in the central control center, and includes information for response activities listed above which require additional billing for services rendered to the insured.

At step 210, the vehicle sensor record file and the trigger event response file are consolidated. Such files will include all the activity for which the insured is to be billed for the prior period. At step 212, all the information

comprising the insured profile, which is already maintained and stored in other insurance files, is applied to the consolidated activity files for the immediately prior period. This insured profile includes the information about coverages including limits and deductibles, which are necessary for establishing the appropriate cost of insurance for the subject insured. At step 214, the acquired consolidated file information from step 210 and the overall insured profile acquired at step 212 are combined and processed against a surcharge or discount algorithm file, which include the specific factors for the various usage patterns and trigger events. The surcharges and discounts are continuously adjusted based on the loss results associated with driving behaviors demonstrated. Finally at step 216, the appropriate billing is produced showing the charges for insurance and other services for the prior period. The billing can be sent electronically or in printed form to the insured for payment.

With particular reference to FIGURE 5, a general diagram of the process for acquiring and recording vehicle insurance related data is illustrated. At step 502, the raw data elements are collected from the vehicle sensors that provide the raw data elements identified above. Calculated data elements are generated in step 504 and derived data elements are generated at step 508. As noted, it is necessary to collect certain database information elements at step 506 prior to generating the derived data elements. A sample of all the data elements is stored in the vehicle at step 510. The sample rate or the recording of the information is controlled based upon the particular insurance billing recording needs predetermined by an algorithm developed by the insurance company. The algorithm will change depending on the particular type of insurance related requirements for the information. At step 512, if a certain incident, for example collision, occurs then a snapshot is generated of all the relevant data elements at the time of the incident, 514.

With reference to FIGURE 6, various examples of sources of insurance related data, the interface required to acquire the data and an example

of the sample rate are illustrated for a preferred embodiment of the subject invention. Accordingly, it can be seen that for a certain information database comprised of maps, speed limits, traffic signs, and highway conditions is stored in the data storage device of the computer and can be obtained on demand
5 therefrom. Acquiring data from vehicle sources such as engine data, body data and electrical data is obtained through a conventional SAEJ 1978 connector with an exemplary sample rate of 10-15 Hz. The other sources of relevant data, such as IVHs, GPS, security system or any additional systems are obtained through various I/O ports and the sample rate can be varied in accordance with the
10 desired goals of the insurer.

One of the useful consequences of the subject invention is that other products could be marketed to a particular vehicle operator based on information provided from the subject invention from the operator's motor vehicle. Since the invention includes processes for gathering, extracting and
15 analyzing information provided by the vehicle, a more informed judgment can be made about a determination of when and which products could be marketed to that motor vehicle operator. For example, by knowing that a vehicle operator travels on vacation in that vehicle to a certain resort location may give rise to a marketing of a package of products particular to the type of travel or the
20 location. Another example would relate to the knowledge that the vehicle operator attends particular types of sporting events which may give rise to certain types of products catered to fans of that sporting event.

The invention has been described with reference to preferred embodiments. Obviously, modifications and alterations will occur to others
25 upon a reading and understanding of the specification. It is our intention to include all such modifications and alterations insofar as they come within the scope of the appended claims or the equivalents thereof.

Having thus described our invention, we claim:

1. A method of determining a cost of automobile insurance based upon monitoring, recording and communicating data representative of operator and vehicle driving characteristics, whereby the cost is adjustable by relating the driving characteristics to predetermined safety standards, the method comprising:

5 monitoring a plurality of raw data elements representative of an operating state of a vehicle or an action of the operator;

recording selected ones of the plurality of raw data elements when said ones are determined to have a preselected relationship to the safety standards;

10 consolidating said selected ones for processing against an insured profile and for identifying a surcharge or discount to be applied to a base cost of automobile insurance; and,

producing a final cost from the base cost and the surcharge or discount.

2. The method as described in claim 1 wherein said recording comprises identifying a trigger event associated with a one of the raw data elements having the preselected relationship and recording both the one raw data element and trigger information representative of the trigger event.

3. The method as described in claim 1 further including immediately communicating to a central control station via an uplink information representative of a trigger event associated with a one of the raw data elements.

4. The method as described in claim 3 further including recording trigger event response information generated by said control station.

5. The method as described in claim 1 further including generating calculated data elements from said raw data elements.

6. The method as described in claim 5 further including generating derived data elements from said raw data elements.

7. The method as described in claim 6 wherein said consolidating comprises accumulating said calculated and derived data elements.

8. The method as described in claim 1 wherein at least a portion of the plurality of raw data elements are within an awareness and selected control of the operator and wherein the method further comprises adjusting by the operator of operator driving behavior thereby causing a change in the portion of raw data elements to obtain the surcharge or discount in the final cost.

9. The method as described in claim 8 wherein the base cost is for a predetermined period of time and wherein the adjusting by the operator is set to occur at predetermined intervals within the predetermined period.

10. The method as described in claim 9 wherein the predetermined period of time comprises two years and the predetermined intervals comprise monthly intervals.

11. A process for acquiring and recording vehicle insurance related data via an on-board computer and recording system comprising steps of:
monitoring a plurality of raw data elements representative of vehicle operating states and driver actions;

5 recording selected ones of the raw data elements in a vehicle record file of an on-board data storage device when said ones are identified as having a relationship material to determination of a cost of insurance;

identifying whether said selected ones comprise a trigger event, and if so identified, communicating information representative of the trigger event to a central control station for storage in a trigger event file; and,

10 consolidating said vehicle record file and said trigger event file in a form for determining a vehicle cost of insurance.

12. The process as defined in claim 11 further including communicating from the central control station an order for dispatch of an emergency or assist vehicle in response to the identifying of a special trigger event determined to require driver assistance.

13. A system of determining a cost of automobile insurance based upon monitoring, recording and communicating data representative of operator and vehicle driving characteristics, whereby the cost is adjustable by relating the driving characteristics to predetermined safety standards, the system comprising:

5 means for monitoring a plurality of raw data elements representative of an operating state of a vehicle or an action of the operator;

means for recording selected ones of the plurality of raw data elements when said ones are determined to have a preselected relationship to the safety standards;

10 means for consolidating said selected ones for processing against an insured profile and for identifying a surcharge or discount to be applied to a base cost of automobile insurance; and,

means for producing a final cost from the base cost and the surcharge or discount.

14. The system as described in claim 13 further including means for immediately communicating to the central control station via an uplink information representative of a trigger event associated with the run of the raw data elements.

15. The system as described in claim 13 further including means for generating calculated data elements from said raw data elements.

16. The system as described in claim 15 further including generating derived data elements from said raw data elements.

17. A method of generating an actuarial class system for determining vehicle insurance costs for retrospectively adjusting and prospectively setting premiums based on data derived from motor vehicle operational characteristics and driver behavior, comprising:

5 monitoring a plurality of raw data elements representing vehicle operating states and driver actions;

recording selected ones of the raw data elements in a vehicle record files when said ones are identified as having a relationship material to determination of a cost of insurance;

10 setting a plurality of actuarial classes associated with corresponding degrees of safety of operation of the vehicle wherein said actuarial classes are derived from aggregating selected ones of the raw data elements; and,

15 consolidating said vehicle record files with selected actuarial classes for determining a corresponding cost of insurance for the vehicle in correspondence with a one of the actuarial classes.

18. The process for determining a cost of insurance as defined in claim 17 wherein said monitoring and recording steps occur concurrently with actual vehicle operation for acquiring the raw data elements during actual vehicle use.

19. The process for determining a cost of insurance as defined in claim 18 wherein at least a portion of the plurality of raw data elements are within an awareness and selective control of a driver, the process further comprising adjusting by the driver of driving behavior to change said portion of raw data elements for consolidating said vehicle record with an other one of the actuarial classes.

20. An integrated system for extracting from multiple sensors, screening, aggregating and applying for insurance rating purposes, data generated by an actual operation of a specific motor vehicle comprising:

- means for extracting a plurality of raw data elements from the multiple sensors wherein the elements are representative of vehicle operating states and driver actions;
- means for screening the raw data elements and aggregating selected ones of the raw data elements in a vehicle record file of an on-board storage device when said selected ones are identified as having a relationship material to determination of a cost of insurance for the vehicle;
- means for associating the aggregated selected raw data elements with predetermined actuarial classes indicative of a degree of safety of operation of the vehicle; and
- means producing a cost of insurance for the vehicle associated with selected ones of the actuarial classes.

data elements, said calculated and derived data elements being further aggregated for association with the selected one of the actuarial classes.

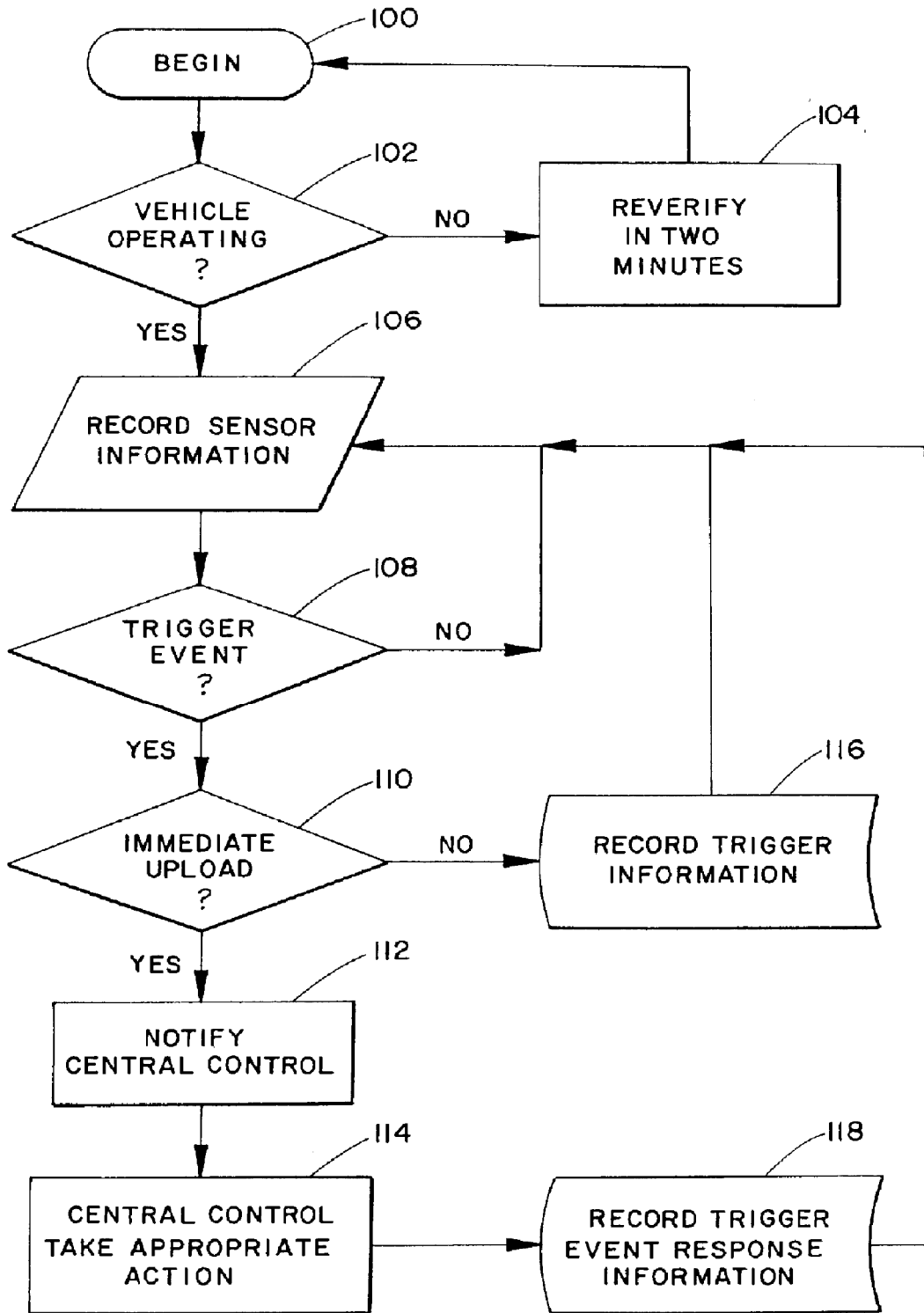
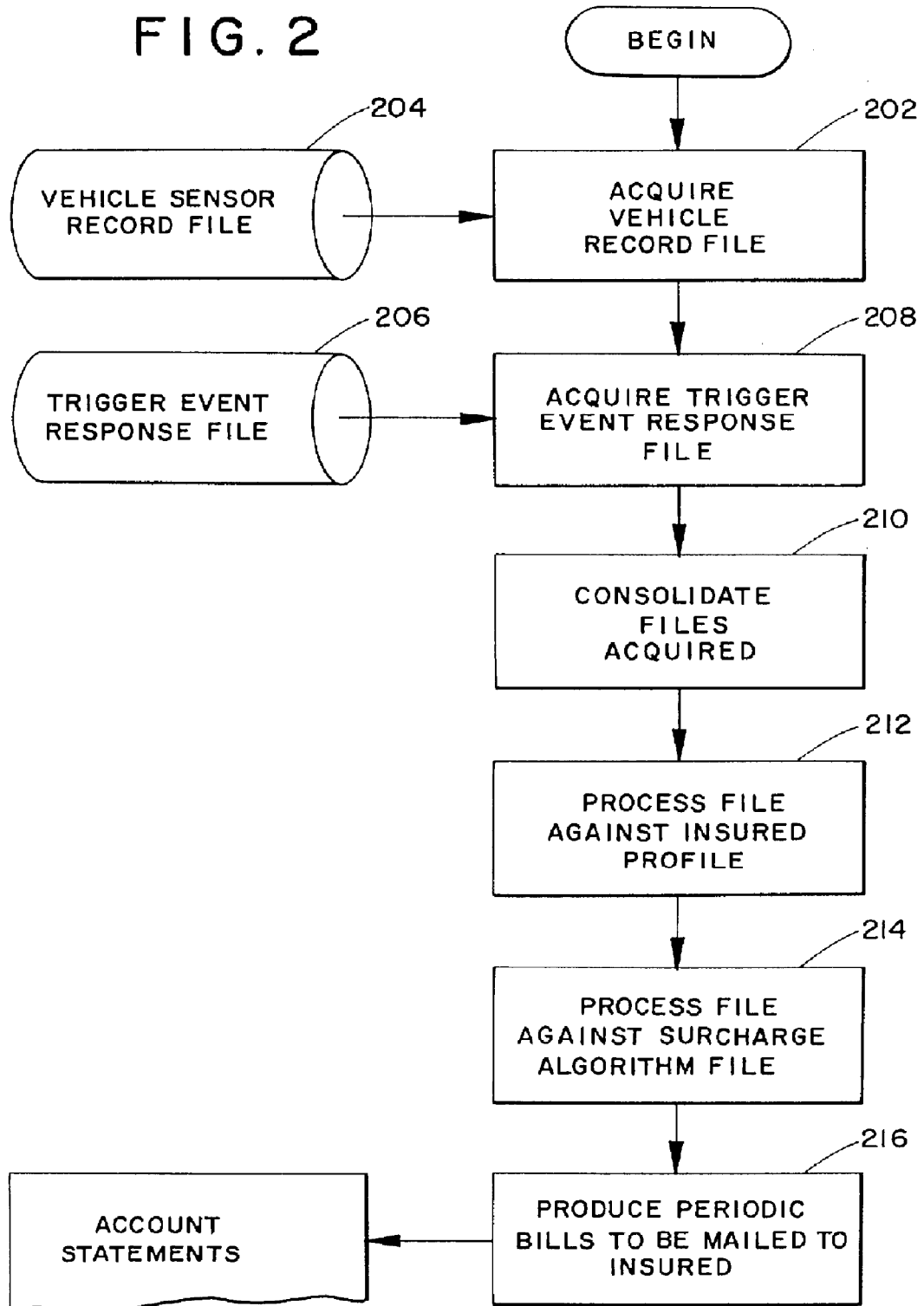

FIG. 1

FIG. 2



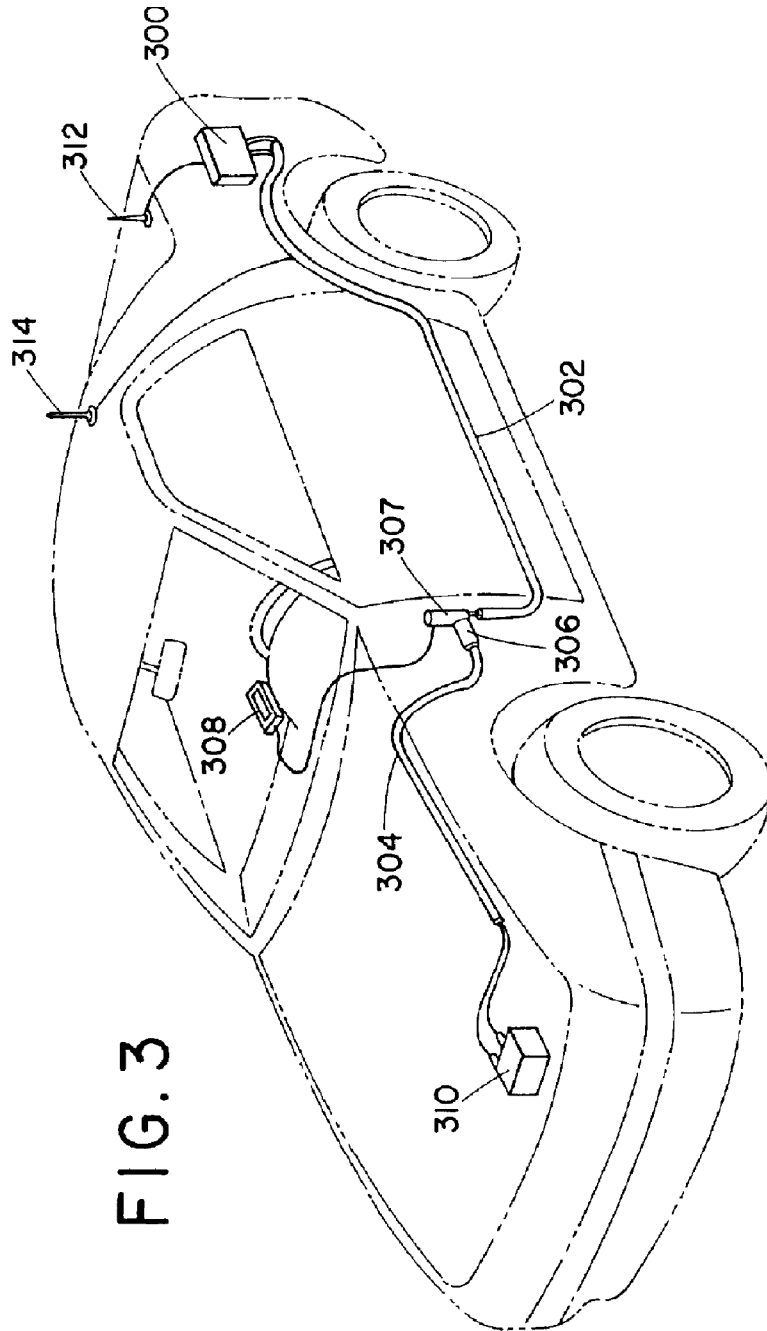

FIG. 3

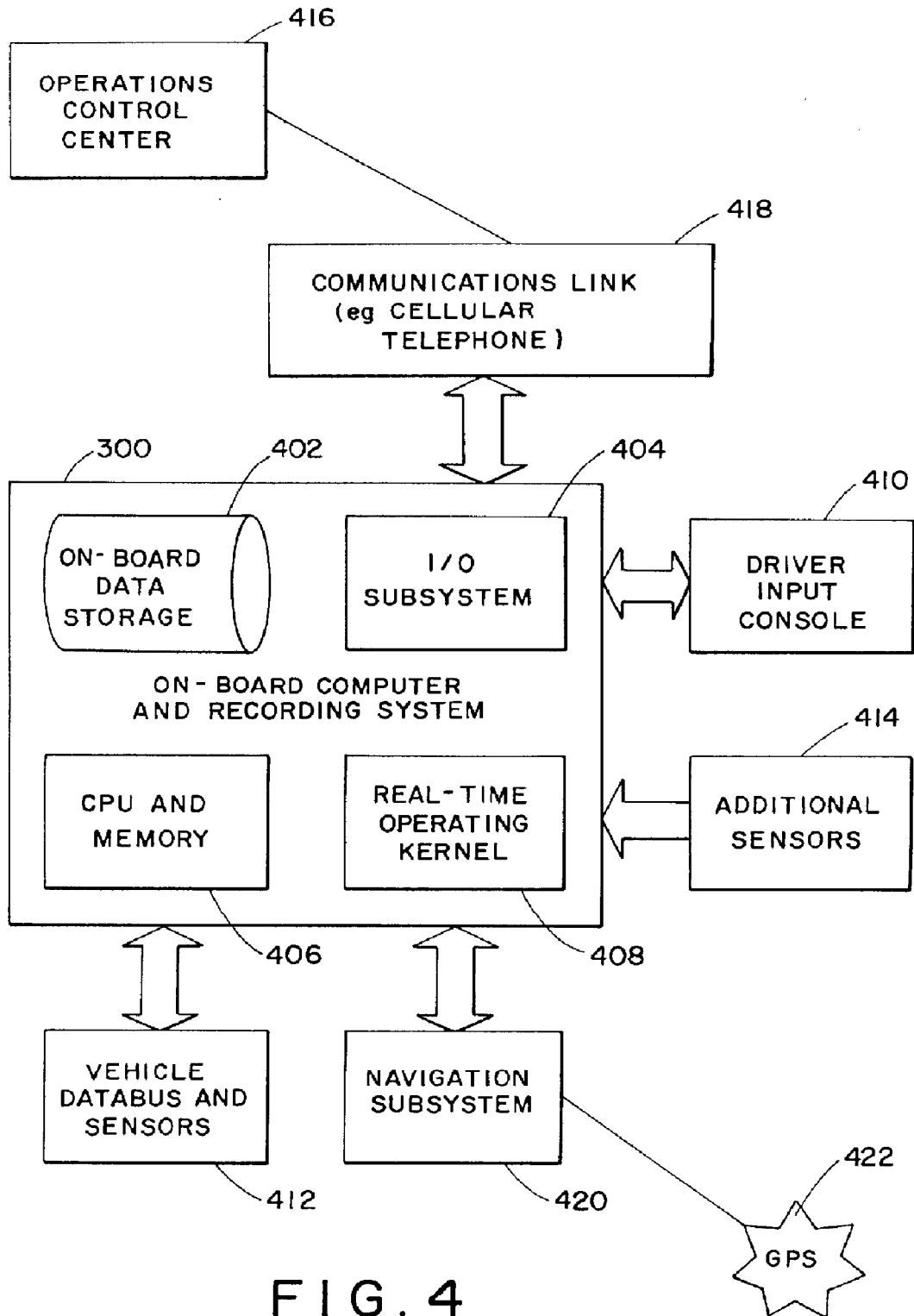
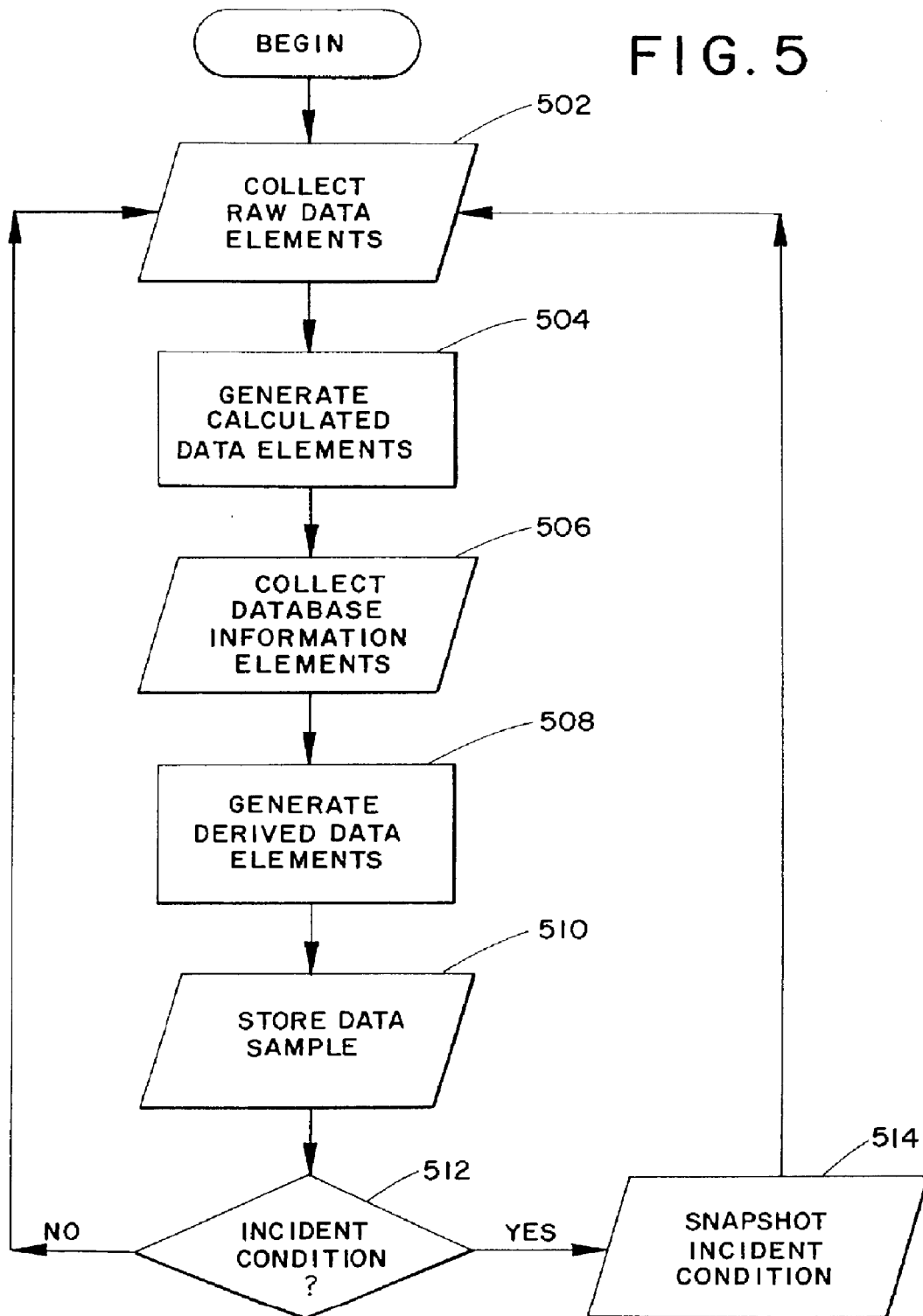

FIG. 4

FIG. 5



<p><u>INFORMATION DATABASE</u></p> <ul style="list-style-type: none"> - MAPS - SPEED LIMITS - TRAFFIC SIGNS - HIGHWAY CONDITIONS - (FUTURE TBD) 	<p><u>INTERFACE</u></p> <ul style="list-style-type: none"> - COMPUTER STORAGE 	<p><u>SAMPLE RATE</u></p> <ul style="list-style-type: none"> - ON DEMAND
<p><u>VEHICLE SOURCES</u></p> <ul style="list-style-type: none"> - ENGINE DATA - BODY DATA - ELECTRICAL DATA 	<p><u>INTERFACE</u></p> <ul style="list-style-type: none"> - SAE J1978 CONNECTOR 	<p><u>SAMPLE RATE</u></p> <ul style="list-style-type: none"> - 10 - 15 HZ
<p><u>OTHER SOURCES</u></p> <ul style="list-style-type: none"> - IVHS DATA - GPS DATA - SECURITY SYSTEM - ADDITIONAL SYSTEM(S) 	<p><u>INTERFACE</u></p> <ul style="list-style-type: none"> - VARIOUS I/O PORTS (eg, RS-232 / 422, ETC.) 	<p><u>SAMPLE RATE</u></p> <ul style="list-style-type: none"> - VARIES

MOTOR VEHICLE INSURANCE PROCESS
VEHICLE DATA ACQUISITION PROCESS FLOW

FIG. 6

12

EUROPEAN PATENT APPLICATION

21 Application number: **90301613.7**

51 Int. Cl.⁵: **G07C 5/08**

22 Date of filing: **15.02.90**

30 Priority: **15.02.89 JP 33595/89**

43 Date of publication of application:
22.08.90 Bulletin 90/34

84 Designated Contracting States:
DE GB

71 Applicant: **HITACHI, LTD.**
6, Kanda Surugadai 4-chome
Chiyoda-ku, Tokyo 101(JP)

72 Inventor: **Asano, Seiji**
Kohzan-Ryo, 2-1034, Higashiishikawa
Katsuta-shi, Ibaraki-ken(JP)
Inventor: **Katogi, Kozo**
3-22-8-301, Chikoku-cho
Hitachi-shi, Ibaraki-ken(JP)
Inventor: **Furuhashi, Toshio**
2-5-39, Shinhara, Mito-shi
Ibaraki-ken(JP)
Inventor: **Watanabe, Shizuhisa**
3702-2, Higashiishikawa
Katsuta-shi, Ibaraki-ken(JP)
Inventor: **Miura, Kiyoshi**
1886-41, Toyooka, Tokai-Mura
Naka-gun, Ibaraki-ken(JP)

74 Representative: **Molyneaux, Martyn William**
c/o Ladas & Parry Isartorplatz 5
D-8000 Munich 2(DE)

54 **System and method of load sharing control for automobile.**

57 A system and method for load sharing processing operations between a vehicle mounted station (105) and a stationary base station (25) having a large capacity host computer is described. The vehicle mounted station has detectors for determining operating conditions of a vehicle and controllers (3, 4, 501) for varying the operating conditions. The controllers are connected to a transmitter-receiver (5) which is arranged to communicate over a path (10) with a transmitter-receiver (11) of the base station. The base station has a host computer (18) having a large memory capacity. At predetermined intervals, for example, distance of travel or at engine stop, the vehicle transmitter (5) transmits operating conditions to the base receiver (11) for data processing and the base transmitter (11) then transmits processed data back to the receiver vehicle (5),

whereupon the controllers (3, 4, 501) modify the vehicle operating conditions. The vehicle operating conditions may be an indication of life expectancy of fuel injectors or sensors, updating data processing maps. The presence of abnormal operating conditions may be detected by the vehicle mounted station, evaluated by the base station and an emergency warning indication provided back to the vehicle mounted station, or if the abnormal condition is not of an emergency nature then counter measures are transmitted from the base station to the vehicle mounted station.

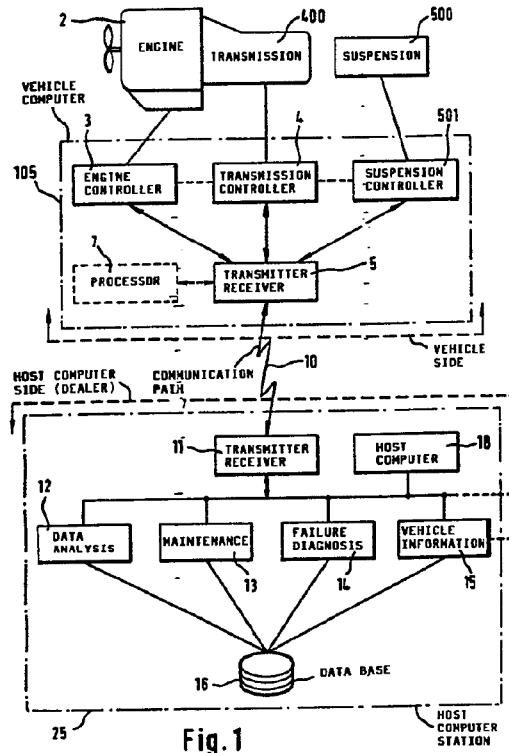

Fig. 1

SYSTEM AND METHOD OF LOAD SHARING CONTROL FOR AUTOMOBILE

BACKGROUND OF INVENTION

1) Field of Invention

This invention relates to a system and method for load sharing processing operations between a vehicle mounted station and a stationary base station and in particular for controlling various items of equipment mounted on an automobile using a large-capacity host computer installed at a stationary base station, e.g. on the ground.

2) Description of Related Art

The number of electrically controlled items used in an automobile, particularly an internal combustion engine, are increasing and control systems therefor are becoming ever more complicated. Several different systems have been attempted to collectively control the various items by time sharing interruptible arithmetic processing using a processor mounted on the automobile.

Such examples include Japanese Patent Publication No. 63-15469 (1988), "Electronic Engine Controller" and Japanese Patent Publication No. 62-18921 (1987), "Computer for Vehicle Control", and controls using a computer are now common.

A central control method using an LSI microprocessor responds to many requirements, such as responding to hazardous components located in the exhaust gas of the internal combustion engine and for reducing fuel consumption. In addition, microprocessors have been utilized in areas extending to attitude control, i.e. levelling control, steering performance and driving stability with regard to a vehicle body suspension control.

Regarding transmission of programs between a base station and the vehicle, for example, there is Japanese Patent Application Laid-Open No. 62-38624 (1987), "Radiocommunication Unit". However, this publication relates to revision of an operational control program for a vehicle mounted processor, and does not teach load sharing under predetermined driving conditions. In addition, regarding mutual communications, there is Japanese Patent Application Laid-Open No. 62-245341 (1987), "Engine Controller", but this describes only installation of a means to load failure diagnosis programs and does not mention any relationship with the driving conditions of the vehicle.

A full dependence upon a vehicle-mounted processor to process all that is included in the above mentioned conventional technologies and

control systems to be newly installed will not only make the system complex but also necessitate a large-capacity processor. Computer control has been used to exploit such advantages as high processing speed and accuracy, easy modification of control characteristics and low cost. However, there are numerous control items, including fuel supply control and ignition control, for which real-time processing is required and implementing all of these together is difficult.

That is, processing all control parameters including the initial setting correction of set values cause by ageing (wear) changes of various characteristics, for example, an engine, transmission, steering, suspension, within a control system having only a vehicle-mounted computer makes the processing program increasingly large.

However, the conventional technologies are neither concerned with this difficulty nor even indicate that there is such a problem.

An object of this invention is to provide a new computer control method for vehicles which at least partially mitigates the above mentioned problems.

SUMMARY OF THE INVENTION

According to one aspect of this invention there is provided a method of load sharing processing operations between a vehicle mounted station and a stationary base station including the steps of said vehicle mounted station detecting operating conditions of the vehicle, transmitting data representative of the detected operating conditions to the base station, said base station receiving data from the vehicle mounted station, processing said data in accordance with data stored by said base station, said base station transmitting processed data to a receiver at said vehicle mounted station and control means at said vehicle mounted station connected to the vehicle mounted receiver and being arranged to perform at least one of revising or displaying the vehicle operating conditions in dependence upon the processed data.

Advantageously the vehicle mounted station detected operating conditions are performed by a detecting means adapted to detect at least one of water temperature, air/fuel ratio air fuel quantity, battery voltage, throttle valve angle opening, engine speed, transmission gear position and suspension setting. In a feature of this invention the vehicle mounted station includes a control means adapted to control at least one of a fuel injector, a transmission gear change means, and a suspension setting

actuator.

Conveniently the data transmitted from the vehicle mounted station to the base station is performed at times of occurrence of predetermined conditions including at least one of the vehicle covering a predetermined distance, detection of the engine ceasing rotation and low fuel tank condition, and advantageously data transmitted between the vehicle mounted station and the base station includes header bits, vehicle identification bits, control data bits, data array bits, check symbol bits and end of transmission bits.

Preferably the vehicle mounted station transmits a request to transmit to the base station, said base station transmits a permission to transmit for the vehicle mounted station, said vehicle transmits data including header bits, vehicle identification bits, control data bits, data array bits and check symbol bits, said base station transmits a receipt acknowledgement and said stationary base station transmits end of transmission bits. In one preferred embodiment the vehicle mounted station contains at least one map indicative of vehicle operating conditions including an indication of ageing in at least one of vehicle injectors and sensors, said map being transmitted by said vehicle mounted station to said base station, said base station comparing transmitted map values with previously transmitted map values and estimating the amount of deterioration in said injectors and sensors, said base station being arranged to estimate the life expectancy of said injectors and sensors and to transmit data indicative thereof to said vehicle mounted station whereby said vehicle mounted station stores said updated information and indicates the life expectancy by visual or aural means. In such an embodiment corrected map values are transmitted from the base station to the vehicle mounted station when engine rotation has ceased for subsequent real time processing and conveniently the vehicle mounted station updates corrected map values in a series of steps during vehicle running and uses said corrected map values for real time control.

Advantageously a life predicting diagnosis of the vehicle is carried out by the base station by using current operating condition signals received from the vehicle mounted station, said predicting diagnosis being carried out at predetermined intervals of time or distance travelled. In a feature of the invention the vehicle mounted station is arranged to detect an abnormality and to transmit data indicative thereof to said base station, said base station evaluates said abnormality and determines whether an emergency retransmission to said vehicle mounted station is necessary to provide an indicative warning by one of a display means or an aural means, and in such feature if the abnormality is not

of an emergency nature the data is stored in a failure chart prior to transmitting counter measures from the base station to said vehicle mounted station.

The vehicle-mounted station may transmit an abnormal condition signal to the base station, the base station transmits a request for data to be analysed, the vehicle mounted base station transmits data for analysis, the base station diagnoses a failure and if an emergency is determined by said base station then said base station immediately transmits a warning for indication by said vehicle mounted station but if said base station determines there to be no emergency then said base station stores data indicative of the abnormality and subsequently transmits counter measures to said vehicle mounted base station whereupon said vehicle mounted base station takes appropriate action in dependence thereof.

According to another aspect of this invention there is provided a system for load sharing processing operations between a vehicle mounted station and a stationary base station, said vehicle mounted station including

detecting means for detecting operating conditions of the vehicle,

first transmitting means for transmitting data representative of the detected operating conditions to the base station,

first receiving means for receiving data from the base station,

and control means for controlling vehicle operating conditions, said control means being connected to said first receiving means,

and said base station comprising second receiver means for receiving data from the vehicle mounted station,

processing means and storage means for processing the data received from the vehicle mounted station based upon information held in said storage means,

and second transmitting means for transmitting the processed data to the first receiving means whereupon the control means is arranged to perform at least one of revise or display the vehicle operating conditions in dependence upon the processed data.

Advantageously the detecting means is adapted to detect at least one of a temperature water sensor, air/fuel ratio, air flow quantity, battery voltage, throttle valve angle opening, engine speed, transmission gear position and suspension setting. Preferably the control means is arranged to control at least one of a fuel injector, a transmission gear change means, and a suspension setting actuator.

Conveniently the first transmitting means is adapted to transmit data comprising a header, a vehicle identification, data control bits, a data array,

a check symbol and an end of transmission indicator.

In a feature of this invention a vehicle-mounted station includes detecting means for detecting operating conditions of a vehicle, transmitting/receiving means for transmitting data representative of the detected operating conditions to a base station capable of evaluating said data, said transmitting/receiving means being adapted to receive evaluated signals from the base station and to apply signals representative of said evaluated signals to a control means adapted to perform at least one of vary or display said operating conditions in dependence upon said received evaluated signals.

In another feature of this invention there is provided a stationary base station adapted to receive data from a vehicle mounted station, said base station including processing means and storage means for processing the data received from the vehicle mounted station based upon information held in said storage means, the base station being adapted to perform at least one of updating/correcting maps carried by a vehicle located processor, vehicle located sensors and injectors, establish the expected life expectancy of said sensors and injectors and further including transmitting means for transmitting processed data to a vehicle.

Thus, the above mentioned object is principally realized by controlling load sharing between computers. A study of computer control for vehicles indicates that data processing is roughly divided into data requiring high-speed real-time processing and data which may be processed in a comparatively long period. For example, ignition timing control and fuel injection control are control subjects that require processing in synchronism with engine rotation so that high-speed processing is required in response to high speed engine rotation. On the other hand, modification of initial settings because of ageing changes such as those in an engine transmission and suspension, may be computed over a relatively long time cycle. Also, controls which have to be computed with a high accuracy take time when processed by a vehicle-mounted computer and only increase the load on the computer.

Also, with regard to failure diagnosis or failure prediction processing when status data is obtained, arithmetic processing itself may be separated from the real-time processing without difficulty. Of course, there may be some diagnoses which require emergency processing and a feature of this invention is to discriminate and act upon abnormal conditions that require urgent actions and diagnoses.

In consideration of the increasing complexity of

the control system and the necessity for higher speed processing accompanied by the increasing r.p.m. of modern engines, this invention carries out load sharing between a vehicle-mounted computer and a stationary host computer.

More specifically a feature of this invention resides in predetermining the processing sharing conditions when specific operating conditions of the engine or specific conditions of the vehicle-mounted computer are detected, transmitting information to and from the host computer and sharing the processing.

The load sharing between the vehicle-mounted computer and the stationary host computer is achieved through the following operations. When the operating conditions for the engine are detected, the subsequent processing thereon is shifted to the host computer to be shared thereby. Thus, increases in load on the vehicle-mounted computer are prevented.

The above operating conditions are detected, for example, at predetermined distance of travel, when cumulative driving time reaches a predetermined time and/or when a predetermined condition is met such as engine stopped or fuel tank low.

Brief Description of the Drawings

The invention will now be described by way of example with reference to the accompanying drawings in which:-

Figure 1 is an overall block diagram of a system according to the present invention,

Figure 2 is a block diagram of the vehicle-mounted computer,

Figure 3 shows occasions when transmission/reception between the computers is performed,

Figures 4(A) and (B) respectively show a data signal and a data transmission/reception sequence,

Figure 5 is a diagram of checking revised items for map matching,

Figure 6 is a diagram of failure diagnosis,

Figure 7 is a diagram of long-term data sampling,

Figure 8 is a flow chart for preparing a revised map,

Figure 9 is a data transmission flow chart when the engine is stopped,

Figure 10 is a flow chart for revised values, and

Figure 11 is a series flow chart of transmissions and receptions.

In the Figures like reference numerals denote like parts.

Description of Preferred Embodiments

In the drawings, Figure 1 shows one embodiment of the overall system where information is transmitted between a vehicle and a host computer located, for example, at a stationary, ground based dealership location through a telecommunications network.

An engine 2 in the vehicle is connected with a vehicle mounted computer 105 including an engine controller 3, a transmission 400 controller 4 and suspension 500 controller 501. In the currently described embodiment only three controllers are shown, but usually a number of these types of controllers are mounted on the vehicle. A transmitter-receiver 5 for transmitting and/or receiving information to and from the host computer 18 is provided within processor 105.

A telecommunication path 10 which may be wired or wireless, e.g. a radio link interconnects the vehicle side located processor 105 with a stationary host computer station 25 including a transmitter-receiver 11 on the host computer station side of the path. There is provided I/O (input/output units) for data analysis 12, I/O for maintenance arithmetic processing 13, I/O for failure analysis computation 14 and I/O for vehicle information 15 over a 2-way bus to the transmitter-receiver 11 and to the host computer 18. The I/O's are also linked to a data base 16 such as a memory store. The host computer side apparatus may be installed at the vehicle dealership or at a vehicle information service center. Although in this exemplary embodiment only 4 I/O's are shown, other I/O's for many other controllers may exist. The host computer 18 may have a capacity of several mega bytes. Also, here a radio communications link connecting the vehicle side and the host side is shown; radio links are preferred as being more practical because the vehicle side is normally moving. Of course, when occasion demands, information can be transmitted or received by wire communication lines from the host computer to a beacon by the roadside for subsequent wireless transmission/reception to the vehicle-mounted computer.

Also, in some cases the engine controller 3 or the transmission controller 4 as shown in Figure 1 has its own built-in processor and carries out respective processings or a vehicle-mounted processor 7 is provided as indicated in broken lines. Hereinafter engine controls are described wherein a processor for engine control is built in.

Figure 2 shows the computer 105 on the vehicle side with the suspension controller 501 omitted. ROM 21, RAM 22 and CPU 7 are connected by a bus line 30 for I/O processing. The bus line consists of a data bus, a control bus, and an

address bus.

Other sequences (of which only two are shown) sense the engine operating conditions, inter alia, the engine cooling water temperature (TWS) 32 and the air/fuel ratio (O₂S) 34. Battery voltage and throttle valve opening and rotation speed also correspond to operating condition signals, but here they are omitted. A multiplexer 36 inputs the operating condition signals into an A/D conversion circuit 38. A register 40 sets A/D converted values.

An inlet pipe air flow sensor (AFS) 51 has its value set in a register 54 after conversion in an A/D converter 52. An engine angle sensor (AS) 56 provides reference signals REF and angle position signals POS to an angle signal processing circuit 58. The processed signals are used to control synchronizing signals and timing signals.

Engine operating condition ON/OFF switches (SWI-SWi) 59-61 indicate parameters such as start engine and engine idle. These signals are input into an ON-OFF switch-condition signal-processing circuit 60 and are used independently or in combination with other signals forming logic signals to determine controls or controlling methods known per se.

The CPU 7 carries out computations based on the above mentioned operating condition signals in accordance with multiple programs stored in ROM 21 and outputs its computation results into respective control circuits through the bus lines 30. Here the engine control circuit 3 and the transmission control circuit 4 have been shown, but numerous other control circuits such as an idle speed control circuit and exhaust gas recirculation (EGR) control circuit are possible.

The engine control circuit 3 has a fuel controller for controlling air/fuel ratios and increases or decreases the amount of fuel supplied by controlling an injector 44. 42 is a logic circuit for these controls. The transmission controller 4 carries out a transmission shift 48 in the transmission 400 through a logic circuit 46 based on the computation results of the driving conditions. A control mode register 62 presents timing signals for various control outputs.

Timing circuit 64-70 control transmitting and receiving operations. For example, circuit 64 outputs a trigger signal into the transmitter-receiver whenever a predetermined distance is travelled and transmits a corresponding engine operating condition signal through the transmitter-receiver to the stationary host computer. A display 90 is used to display instructions to the driver.

Circuit 66 is used to detect an engine stopped and to trigger an output signal thereupon. Circuit 68 is used to detect a low fuel tank condition and trigger an output signal thereupon. Circuit 70 is used to check whether predetermined conditions

are met and when satisfactory, generate a trigger output signal. Figure 3 shows symbol illustrations of these circuits.

To sum up, circuits 66 to 70 produce signals which decide timing to transmit operating condition data to the stationary host computer. For example, from the circuit 64 which generates a signal whenever a predetermined distance has been travelled, it is possible to diagnose the operating condition per the predetermined travel distance. When only condition signals are transmitted, the host side computer makes a diagnosis based on deviations from the previous values or past condition signal data and conveys instructions based on its results to the vehicle-mounted computer. The vehicle-mounted computer gives driver instructions through a display or alarm in dependence upon the severity or grade of those instructions or modifies processing programs or sets parameter values.

Figure 4(A) shows an example of a data array and Figure 4(B) shows a data transmitting and receiving sequence during data communications between the vehicle-mounted computer and the stationary, e.g. ground, host computer (here a dealer located computer). A subject vehicle is specified by a header and a vehicle number (a number that is unique to the vehicle such as the engine number or the car body number).

Figure 5 shows a processing example when correction items in the map matching are checked (data analysis), the transmitter-receiver 11 at the dealer side being omitted for clarity. When controlling an engine via a microcomputer, control data is computed based on output conditions of each sensor. In addition, a system is used for subsequent engine control by responding to various engine conditions and by storing control data computed as a learning map. Figure 5 shows an example of using other control data values after corrections by analysing such control data stored in the so-called learning map or data to be changed together with other engine controls.

The program processing on the vehicle side is assumed in this example to be to check a map (step 5a). This satisfies conditions by the circuits 64 to 70 as described previously and the checking program of the map starts. Although this is simply called map matching, there is a learning map for ignition timing based on the output of a knock sensor or a learning map for defining an injection pulse width of the fuel injector in the fuel/air (O_2 feedback) from an exhaust to an inlet fuel injector, i.e. an O_2 detector detects if exhaust gas mixture is lean or rich and sends a pulse in dependence thereon to the fuel injector. Map revision is described later in detail with reference to Figure 8. Now, the flow of the transmission processing at the time of map matching is generally explained.

In step 5a, the vehicle-mounted computer checks data in the map by using various methods. For example, when data values contained in the learning map for defining the injection pulse width of the injector using parameters of number of revolutions of the engine N and engine load Qa/N (where Qa is quantity of air) during O_2 feedback are analysed, the corresponding map of the output of the inlet pipe air flow sensor and the air flow quantity is revised by comparing actual data values with previous data values and if the comparison result exceeds a predetermined value then the actual value is used to reset the map, thus effecting a "learning" process. The injector factor is also revised when the injector pulse width of the injector is determined in relation to the engine load Qa/N . Based on checking of the map, engine control data revisions are determined. In step 5b, the vehicle-mounted computer selects necessary data values in the map under check to be used to newly correct engine control data or computes data to be transmitted to the host computer by processing data values stored in the map and stores them in RAM as a map. When data to be transmitted is determined such is rendered as a trigger signal, the map arithmetically processed in the vehicle-mounted computer and contained in RAM is transmitted through the transmitter-receiver 5. The dealer side (host computer), having received this, executes its program based on received signals. In step 5c, data signal reception from the vehicle-mounted computer is started. However, in step 5d, if the dealer-side is already receiving data from another vehicle, a wait instruction is issued in step 5e. When not receiving data from another vehicle, the received data is stored in the memory of the host computer in step 5f. In step 5g, present memory values are compared with past values previously transmitted to the host computer. In step 5h, the amount of deterioration in actuators, such as injectors, and sensors such as inlet air quantity (Qa) sensors, is estimated based on the compared results. Next, in step 5i, the remaining life is estimated from the deterioration amount. In step 5j, data transmitted from the vehicle-mounted computer is computed in accordance with a predetermined program to determine data to be corrected at the vehicle computer. In step 5k, this data is transmitted through the transmitter-receivers 11 and 5. When it receives a transmission signal from the host computer, the vehicle-mounted computer starts the arithmetic processing. When in step 5l receiving the corrected map transmitted from the host computer commences, it is stored in RAM in step 5m. In step 5n, the corrected map is re-written when the engine restarts after stoppage. In step 5p, notification is made to the driver visually, through the display or audibly that the map has been re-

written. This is an example of notifying the driver for caution's sake, because correction items of the map may influence whether the vehicle should be driven. However, for cases that do not specifically require this, notification can be omitted. Also, in step 5p, it is possible to display the deterioration amount and remaining life of the injector or sensor. Alternatively, re-writing the map at the time of restarting the engine for example and/or shifting to the corrected map during travel can be made. However, at this time a method to enable a smooth transition is preferred. For example, methods as follows may be carried out, in that, when the deviation before correction is smaller than a predetermined value, a sequential transition is made and when the deviation is larger than the predetermined value, its intermediate value (in some cases, plural intermediate values) is established and shifted step by step to a corrected map. In addition, re-writing the map may also be carried out in a predetermined period after the power key switch is turned off, i.e. power is supplied for a predetermined period after the power key switch is turned off to enable the map to be re-written or memorised.

Figure 6 shows an example of a failure diagnosis, the transmitter-receiver 11 again being omitted for clarity. The vehicle-mounted computer carries out time-sharing computations of the injection pulse width and ignition timing by the injector in real time. For this, computations for a failure diagnosis are made in the intervals of these computations and only a basic diagnosis is made. This embodiment is based on the concept of having the vehicle-mounted computer make a basic abnormal diagnosis and transmit the data to the host computer. The host computer then makes more advanced, comprehensive and appropriate diagnosis using data indicative of the condition of other control subjects.

In step 6a, the diagnostic mode starts. This is carried out in parallel with the general program and for example, is repetitive at predetermined intervals of about 60 ms. In step 6b, a decision on whether any abnormality exists is made based on the diagnosis results. When no abnormality exists, the process ends. When an abnormality exists, the abnormal code is transmitted to the host computer on the dealer side through the transmitter-receivers 5 and 11. The host computer is triggered by the transmitted signal and executes a more detailed failure diagnosis program. Having received the abnormal code in step 6c, in step 6d, the host computer selects comprehensive control data necessary for failure diagnosis based on the abnormal code and asks the vehicle-mounted computer to transmit data for decision. Upon receipt of the request for transmission, the vehicle-mounted computer transmits the data for decision in step 6e. In

step 6f, the host computer diagnoses comprehensively the failure using the data for decision transmitted from the vehicle-mounted computer. In this case, because the host computer is not carrying out the real-time arithmetic processing such as computation of the injector's injection pulse width, if the results of the failure diagnosis in step 6f in which an overall diagnosis is possible based on the data transmitted from the vehicle-mounted computer indicate an emergency, the host computer immediately transmits emergency measures to the vehicle-mounted computer. If an emergency treatment is not specifically diagnosed, the host computer stores the received data in a failure chart in step 6i and subsequently transmits countermeasures to the vehicle-mounted computer in step 6j and completes the diagnostic flow in step 6l. In step 6k, the vehicle-mounted computer takes actions based on the countermeasure signals from the host computer and ends the diagnostic mode process at step 6m.

Figure 7 shows an example regarding life prediction or failure prediction in accordance with data collected through sampling over a long period of time in which the transmitter/receiver 11 is again omitted for clarity. In step 7a, the vehicle-mounted computer carries out data sampling at every predetermined interval to detect abnormalities. Detection of abnormalities in this case is a very simple detection of abnormalities and a high-level failure diagnosis is carried out by the host computer. In step 7b, an existence of abnormalities is confirmed and in step 7c, the vehicle-mounted computer transmits the necessary data including sampling values to the host computer through the transmitter-receivers 5, 11 and completes the flow process. If there is no abnormality, the flow process is completed. In addition, in view of the long-term data sampling, high-level failure diagnoses by the host computer may be made at every predetermined distance of travel as shown in Figure 3 or by the circuit 64 in Figure 2. Upon receipt of the data transmission signal from the vehicle-mounted computer, the host computer starts the failure diagnosis program in step 7d. In step 7e, control data accumulated in the memory of the host computer is analyzed to predict life expectancy. In step 7f, defective parts are specified from data analysis results. In step 7g, the degree of emergency is determined. If there is an emergency, the host computer transmits a signal to that effect to the vehicle-mounted computer through the transmitter-receivers 11, 5 in step 7i. The host computer makes life expectancy predictions based on the analysis results and stores the predictions in the failure chart at step 7i. At step 7j, countermeasure signals are transmitted to the vehicle-mounted computer to complete the flow process in step 7i.

The vehicle mounted computer, in step 7k, takes action in accordance with the signal transmitted from the host computer and completes the process.

Thus, this invention has shared processing where items are divided into those requiring processing by a vehicle-mounted processor and those requiring long-term or highly accurate computations by a stationary larger computer. Having a vehicle-mounted processor execute all processings, as has been performed in the prior art, only makes a vehicle-mounted processor larger in capacity and physical size.

With regard to checking of the matching map as well as checking of revision items in the map, as performed in steps 5a and 5b of Figure 5, a detailed explanation will now be made by taking map revisions based on the O₂ feedback map as an example. Although there is a prior application (Japanese Patent Application No. 63-283886 (1988)) by the same applicant as this invention regarding O₂ feedback and learning based thereon, its basic methods and concepts are described as follows. The injection time of the injector is determined by the equations (1) and (2) below.

$$T_i = T_p \cdot (K_e + K_t - K_s) \cdot (1 + K_i) + T_s \quad (1)$$

$$T_p = K_{const} \cdot Q_a / N \quad (2)$$

where

Kconst : injector factor

Tp : basic injection time

: correction factor for air/fuel ratio

Ts : delayed injection time of injector due to mechanical and electrical propagation lag

Ke : steady-state learning factor

Kt : transient learning factor

Ki : a correction factor

Ks : shift factor

Qa : sucked air flow amount

N : number of engine revolutions

That is, a basic fuel injection time Tp is determined through a sucked air flow amount of Qa of the engine and the rotational speed N from equation (2) and the correction factor is changed and corrected so that a stoichiometric air/fuel ratio is obtained based on the output of the air/fuel (O₂) sensor. Here, the correction factor largely deviates from 1.0 because of "ageing" changes in actuators such as the injectors and of sensors. Therefore, supplementary corrections are performed by means of the steady-state learning factor Ke and the transient learning factor Kt to make the correction factor be nearer to 1.0 and determine the fuel injection Time Ti.

Figure 8 shows a flow chart for preparing correction maps. In step 8a, the O₂ feedback learning map is checked to decide whether there are maps requiring corrections. Based on the check results, a decision is made in step 8b whether there are

maps requiring re-matching. If not, the process ends. In this embodiment, a Ts map, a Kconst map and a Qs table are illustrated as maps requiring re-matching. Maps requiring re-matching are specified in steps 8c, 8e and 8h and in each of steps 8d, 8f and 8i, control data to be transmitted to the host computer is selected or computed if necessary and is stored in the RAM address of the vehicle-mounted computer to prepare the maps. In step 8j, header data of revision items corresponding to the map to be corrected is prepared, the corrected map is read out from RAM to write in the transmission area in preparation for transmission to the host computer in step 8k and the flow is completed.

Criteria to decide whether a revision is required and specific revision procedures are made in accordance with, for example, prior Japanese Patent Application No. 63-181794 (1988) of the present applicants.

Figure 9 shows an example of data transmission and reception when an engine stops. The engine is controlled by a microcomputer by computing control values to control actuators such as the injector based on outputs of each sensor, including the inlet air flow and crank angle sensors. Each datum may be required for failure diagnosis and matching by the host computer. Necessary data is taken in and stored in the host computer at every ignition key turn OFF.

In step 9a, a decision is made whether the ignition key is turned ON or OFF. When turned ON, the engine is running and the flow terminates. In step 9b, a decision is made whether the engine is rotating or not. When rotating, the flow ends. In steps 9c and 9d, a decision is made whether data transmission to the host computer is required or not. In other words, when the previous revision request is issued in step 9c and when there are revision items of the map to be corrected in step 9d, a decision is made that data transmission is required and operation proceeds to step 9e. Otherwise, operation proceeds to step 9i. In step 9e, a mask setting for transmission/reception is made to prevent interruption, the transmission/reception program is executed in step 9f and the mask is cleared in step 9h. In step 9h, transmission/reception is carried out through the transmitter-receiver 5 if transmission/reception is possible. If transmission/reception is not possible, the flow ends. When transmission/reception is made, the flow proceeds to step 9i, self-shut off and automatically stops the computer after the elapse of a predetermined time.

Next, the execution of data matching in step 5j of Figure 5 by the host computer will be explained by taking Figure 10 as an example.

Figure 10 is an example of obtaining deviations from the previous revision data and for evaluating

correction values. In step 10a, a decision is made whether the revision is the first or not. If it is the first revision, basic data is stored in step 10c. If not, the previous data is retrieved. In step 10d, a correction value is calculated from the map data transmitted from the vehicle-mounted computer, revised (corrected) values in each map are calculated in step 10e, the calculated values are stored in the memory in step 10f and the process completes.

Figure 11 is an exemplary flow diagram of data transmission/reception. The vehicle-mounted computer starts a flow process at every predetermined interval. In step 11a, a decision is made whether the revision request has been completed or not. When completed, the flow proceeds to 11g and moves to the data return transmission program. If there is a transmission return request in step 11b, necessary data is transmitted to the host computer. Next, the vehicle-mounted computer awaits until the host computer transmits a signal permitting transmission. In step 11i, the host computer receives the transmission signal from the vehicle-mounted computer and at step 11m determines if it is ready to receive the transmission from the vehicle-mounted computer. If it is ready a signal permitting transmission is derived in step 11n and if it is not ready then a wait instruction is issued in step 11o. The vehicle-mounted computer transmits data in step 11d if it has received a transmission permit in step 11c, lights up the display lamp in step 11e and applies a revision request flag ON in step 11f. If there is no transmission permit, the flow process ends. The host computer, which has received data, processes the data in step 11p and then, if the vehicle-mounted computer requires data return transmission in step 11g, decides whether return transmission is possible or not in step 11q. If return transmission is possible, it transmits back the processed data in step 11r. If it is not possible to transmit data back, the host computer issues a wait instruction in step 11s and transmits back the data in step 11t. The vehicle-mounted computer releases the wait condition when a signal permitting data return transmission is transmitted in step 11h, re-writes the data in step 11i based on the data transmission from the host computer in step 11t, turns OFF the display lamp in step 11j, puts OFF the revision request flag in step 11k and completes the process.

Having now fully described the present invention it will be realised that processing by a vehicle-mounted computer can be transferred to a stationary host computer as the occasion demands and real-time vehicle controls are implemented effectively without increasing the workload of the vehicle-mounted computer.

Claims

1. A method of load sharing processing operations between a vehicle mounted station (105, 2, 400, 500) and a stationary base station (25) including the steps of said vehicle mounted station detecting operating conditions of the vehicle, transmitting data representative of the detected operating conditions to the base station, said base station receiving data from the vehicle mounted station, processing said data in accordance with data stored by said base station, said base station transmitting processed data to a receiver at said vehicle mounted station and control means at said vehicle mounted station connected to the vehicle mounted receiver and being arranged to perform at least one of revising or displaying the vehicle operating conditions in dependence upon the processed data.

2. A method as claimed in claim 1 wherein the vehicle mounted station detected operating conditions are performed by a detecting means adapted to detect at least one of water temperature (32), air/fuel ratio (34) air fuel quantity (Q_a), battery voltage, throttle valve angle opening (56), engine speed (N), transmission gear position (4) and suspension setting (501).

3. A method as claimed in claim 1 or 2 wherein the vehicle mounted station includes a control means adapted to control at least one of a fuel injector (44), a transmission gear change means (400), and a suspension setting actuator (500).

4. A method as claimed in any preceding claim wherein the data transmitted from the vehicle mounted station to the base station is performed at times of occurrence of predetermined conditions including at least one of the vehicle covering a predetermined distance, detection of the engine ceasing rotation and low fuel tank condition.

5. A method as claimed in any preceding claim wherein data transmitted between the vehicle mounted station and the base station includes header bits, vehicle identification bits, control data bits, data array bits, check symbol bits and end of transmission bits.

6. A method as claimed in any preceding claim wherein the vehicle mounted station transmits a request to transmit to the base station, said base station transmits a permission to transmit for the vehicle mounted station, said vehicle transmits data including header bits, vehicle identification bits, control data bits, data array bits and check symbol bits, said base station transmits a receipt acknowledgement and said stationary base station transmits end of transmission bits.

7. A method as claimed in any preceding claim wherein the vehicle mounted station contains at least one map indicative of vehicle operating conditions including an indication of ageing in at least

one of vehicle injectors and sensors, said map being transmitted by said vehicle mounted station to said base station, said base station comparing transmitted map values with previously transmitted map values and estimating the amount of deterioration in said injectors and sensors, said base station being arranged to estimate the life expectancy of said injectors and sensors and to transmit data indicative thereof to said vehicle mounted station whereby said vehicle mounted station stores said updated information and indicates the life expectancy by visual or aural means.

8. A method as claimed in claim 7 wherein corrected map values are transmitted from the base station to the vehicle mounted station when engine rotation has ceased for subsequent real time processing.

9. A method as claimed in claim 7 wherein the vehicle mounted station updates corrected map values in a series of steps during vehicle running and uses said corrected map values for real time control.

10. A method as claimed in any preceding claim wherein a life predicting diagnosis of the vehicle is carried out by the base station by using current operating condition signals received from the vehicle mounted station, said predicting diagnosis being carried out at predetermined intervals of time or distance travelled.

11. A method as claimed in any preceding claim wherein the vehicle mounted station is arranged to detect an abnormality and to transmit data indicative thereof to said base station, said base station evaluates said abnormality and determines whether an emergency retransmission to said vehicle mounted station is necessary to provide an indicative warning by one of a display means or an aural means.

12. A method as claimed in claim 11 wherein if the abnormality is not of an emergency nature the data is stored in a failure chart prior to transmitting counter measures from the base station to said vehicle mounted station.

13. A method as claimed in any of claims 1 to 10 wherein the vehicle mounted station transmits an abnormal condition signal to the base station, the base station transmits a request for data to be analysed, the vehicle mounted base station transmits data for analysis, the base station diagnoses a failure and if an emergency is determined by said base station then said base station immediately transmits a warning for indication by said vehicle mounted station but if said base station determines there to be no emergency then said base station stores data indicative of the abnormality and subsequently transmits counter measures to said vehicle mounted base station whereupon said vehicle mounted base station takes appropriate action in

dependence thereof.

14. A system for load sharing processing operations between a vehicle mounted station (105, 2, 400, 500) and a stationary base station (25), said vehicle mounted station including
 5 detecting means (3, 4, 501) for detecting operating conditions of the vehicle,
 first transmitting means (5) for transmitting data representative of the detected operating conditions to the base station,
 10 first receiving means (5) for receiving data from the base station,
 and control means (3, 4, 501) for controlling vehicle operating conditions, said control means being
 15 connected to said first receiving means,
 and said base station comprising second receiver means (11) for receiving data from the vehicle mounted station,
 processing means (18, 12-15) and storage means
 20 (16) for processing the data received from the vehicle mounted station based upon information held in said storage means (16),
 and second transmitting means (11) for transmitting the processed data to the first receiving means (5)
 25 whereupon the control means (3, 4, 501) is arranged to perform at least one of revise or display the vehicle operating conditions in dependence upon the processed data.

15. A system as claimed in claim 14 wherein the detecting means is adapted to detect at least one of a temperature water sensor (32), air/fuel ratio (34), air flow quantity (Q_a), battery voltage, throttle valve angle opening (56), engine speed (N), transmission gear position (4) and suspension setting (501).

16. A system as claimed in claim 14 or 15 wherein the control means is arranged to control at least one of a fuel injector (44), a transmission gear change means (400), and a suspension setting actuator (500).

17. A system as claimed in any of claims 14 to 16 wherein the first transmitting means (5) is adapted to transmit data comprising a header, a vehicle identification, data control bits, a data array, a check symbol and an end of transmission indicator.

18. A vehicle mounted station including detecting means (3, 4, 501) for detecting operating conditions of a vehicle, transmitting/receiving means (5) for transmitting data representative of the detected operating conditions to a base station capable of evaluating said data, said transmitting/receiving means being adapted to receive evaluated signals from the base station and to apply signals representative of said evaluated signals to a control means (3, 4, 501) adapted to perform at least one of vary or display said operating conditions in dependence upon said received evaluated signals.

19. A stationary base station (25) adapted to receive data from a vehicle mounted station, said base station including processing means (18, 12-15) and storage means (16) for processing the data received from the vehicle mounted station based upon information held in said storage means (16), the base station being adapted to perform at least one of updating/correcting maps carried by a vehicle located processor, vehicle located sensors and injectors, establish the expected life expectancy of said sensors and injectors and further including transmitting means (11) for transmitting processed data to a vehicle.

5

10

15

20

25

30

35

40

45

50

55

11

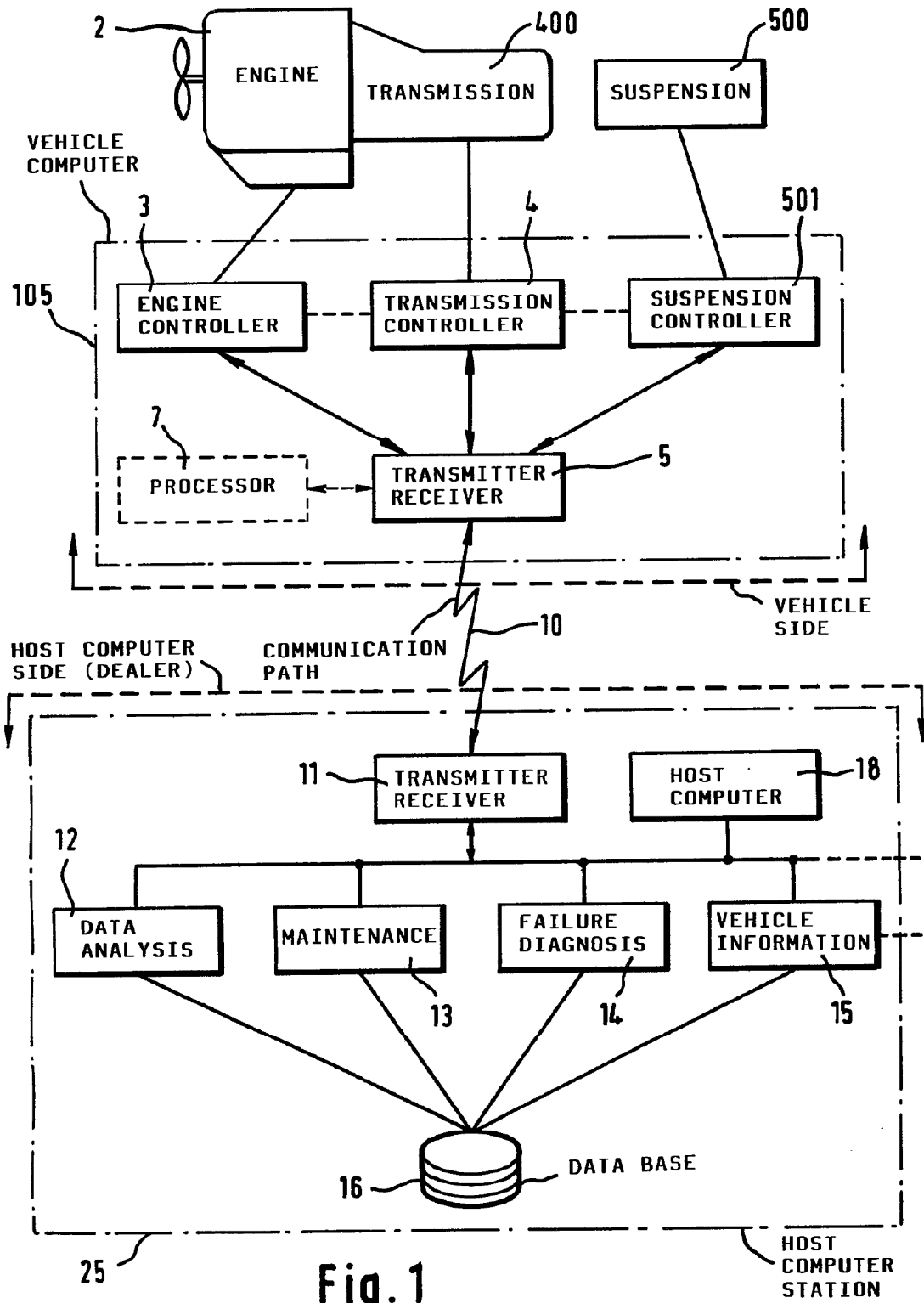

Neu eingereicht / New
Nouvellement d'ep

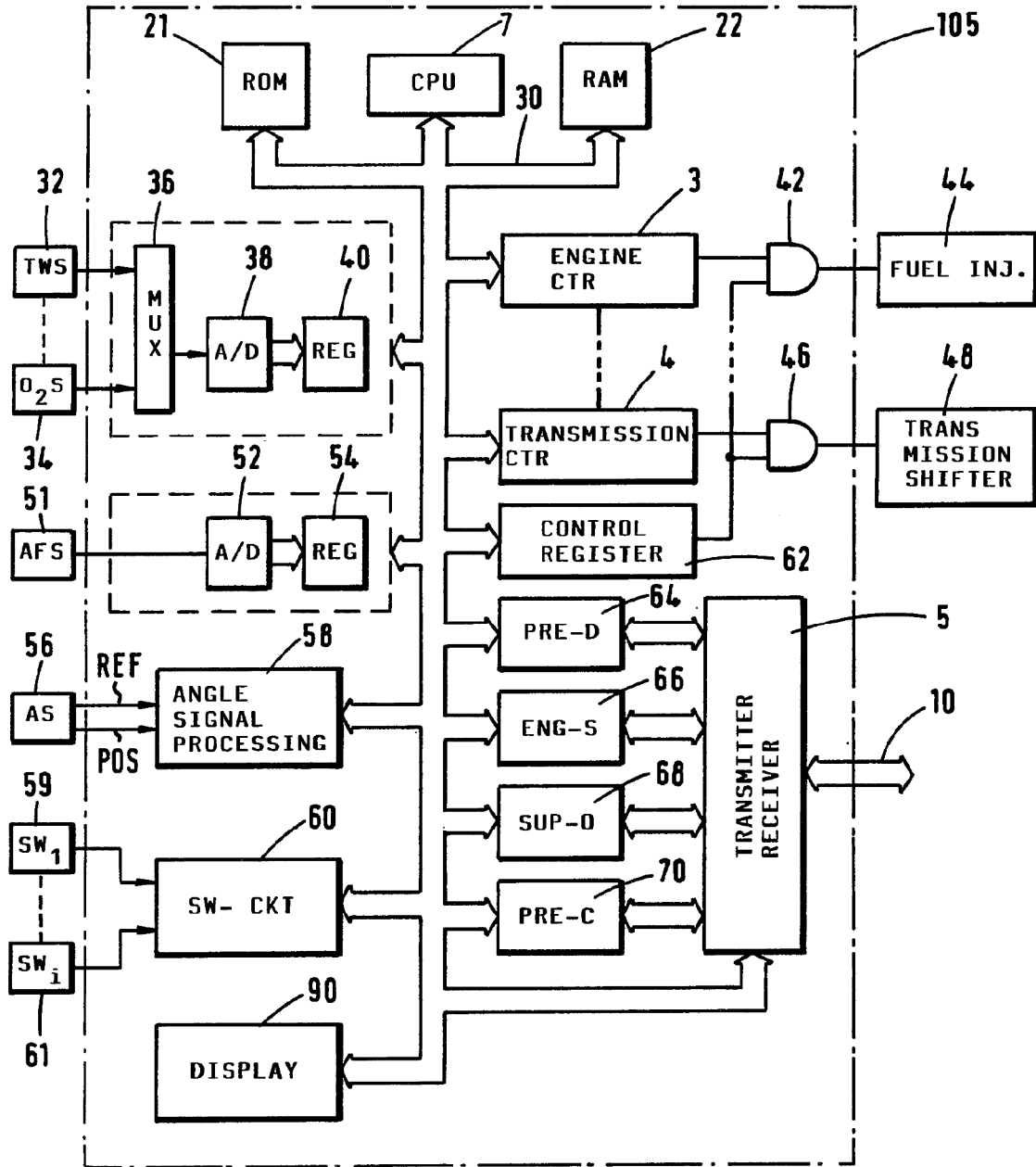

Fig. 2

Neu eingereicht / Ne
Nouvellement dé

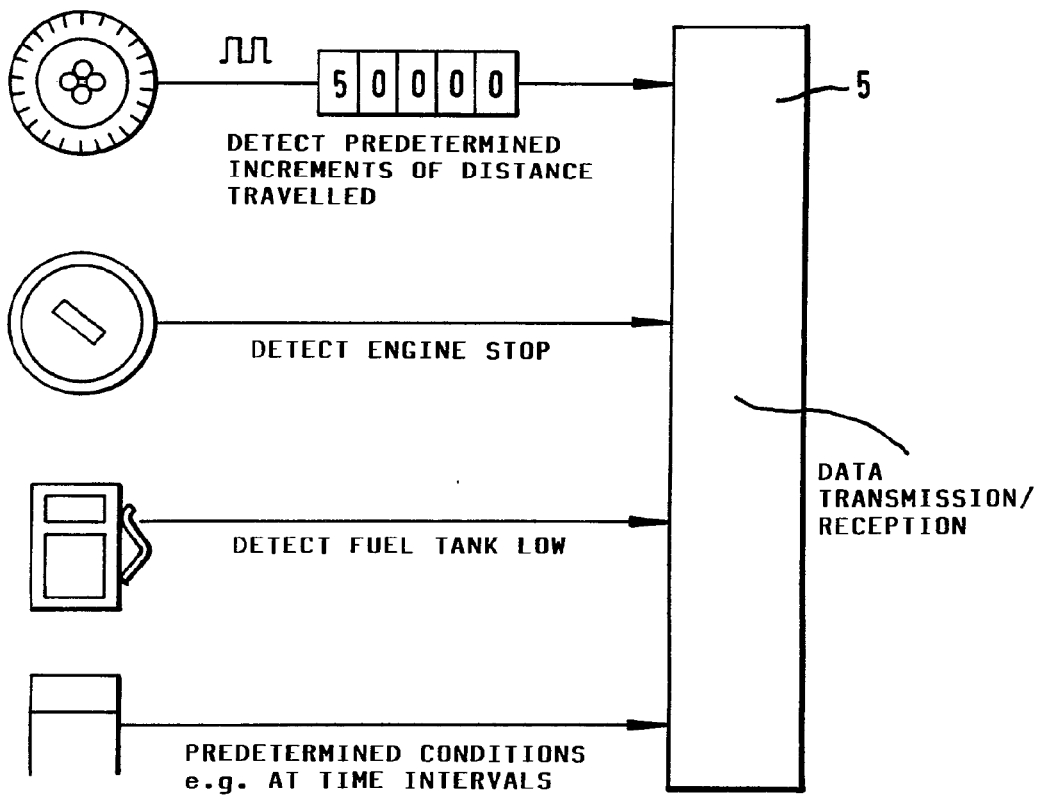

Fig.3

1100 4100 0101 / New
1100 0101 0101 / New

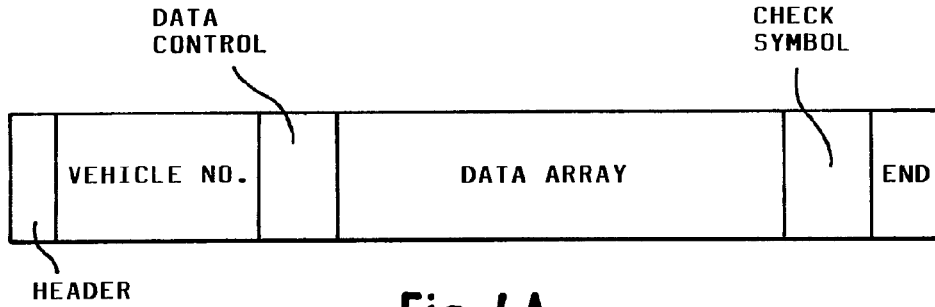

Fig.4A

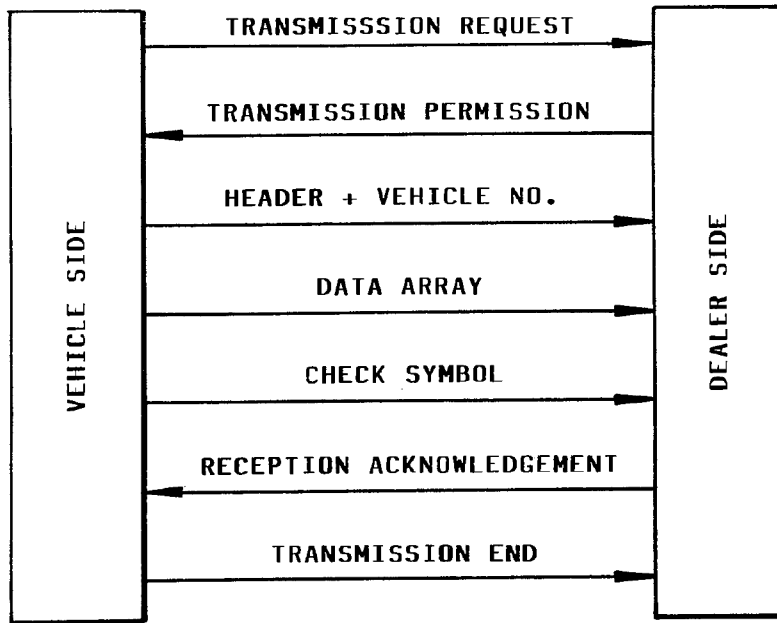

Fig.4B

Neu eingereicht / Ne
 Dépôt de brevet

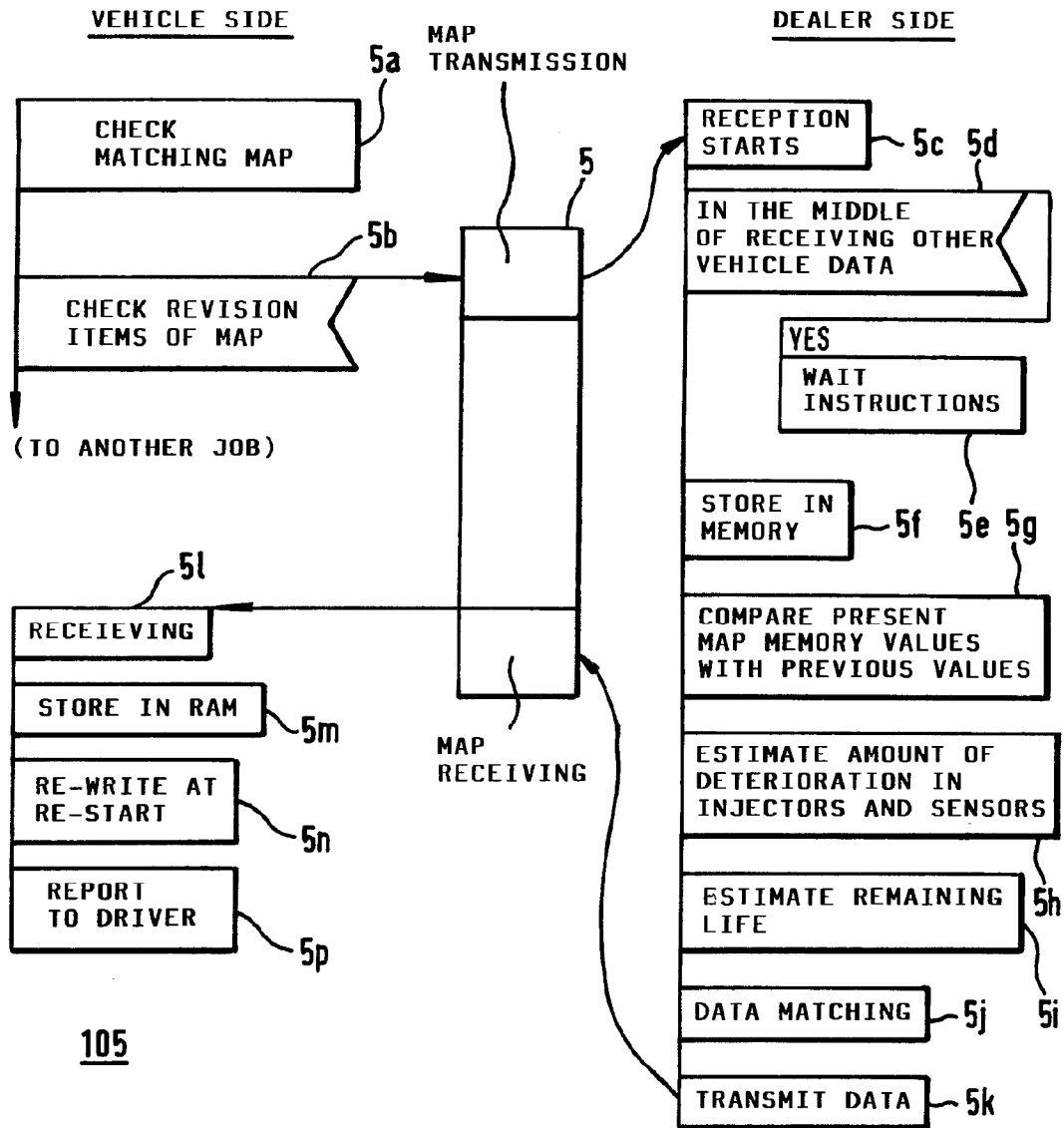
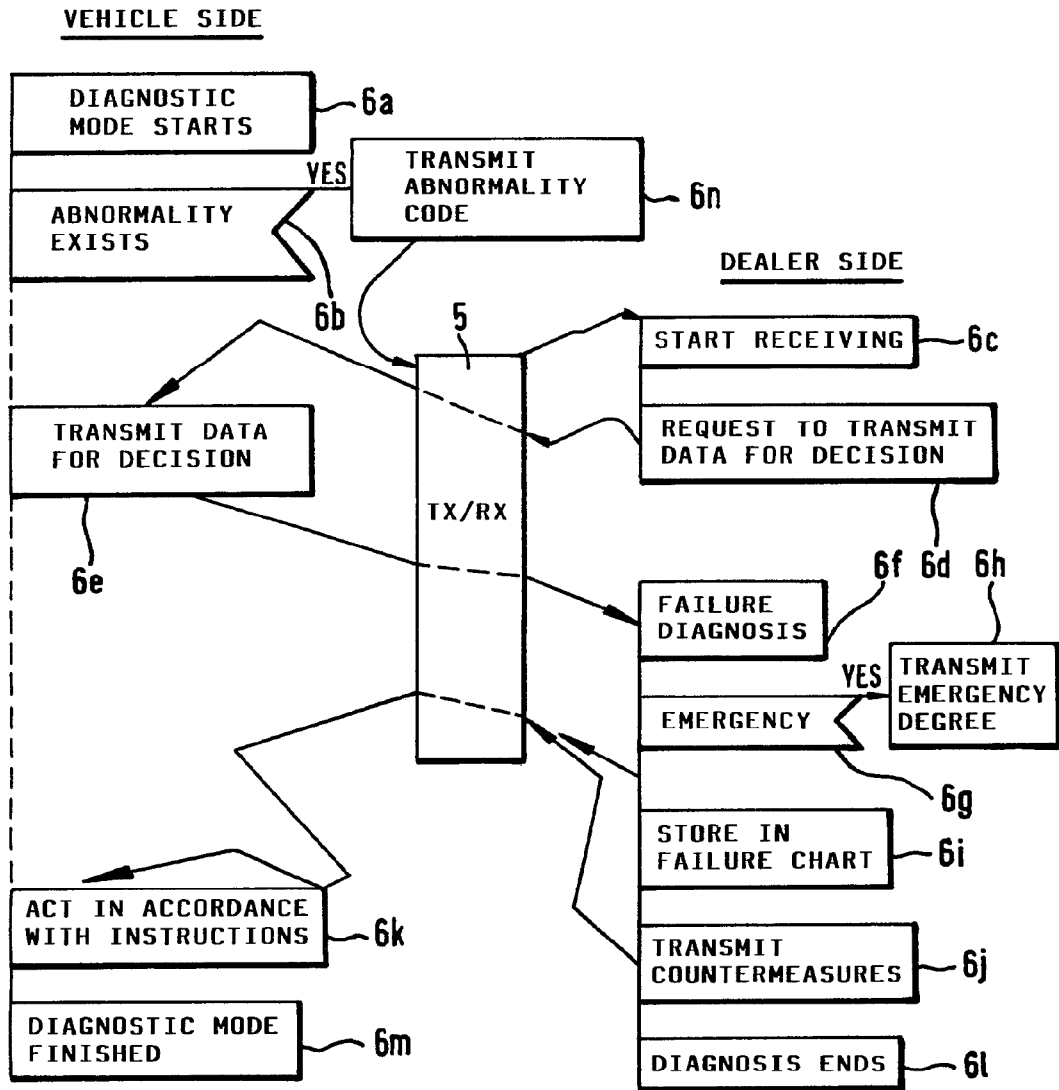

Fig. 5

Man of the month / Now
 Man of the month



105

Fig. 6

25

Non alignement / Non
alignement déposé

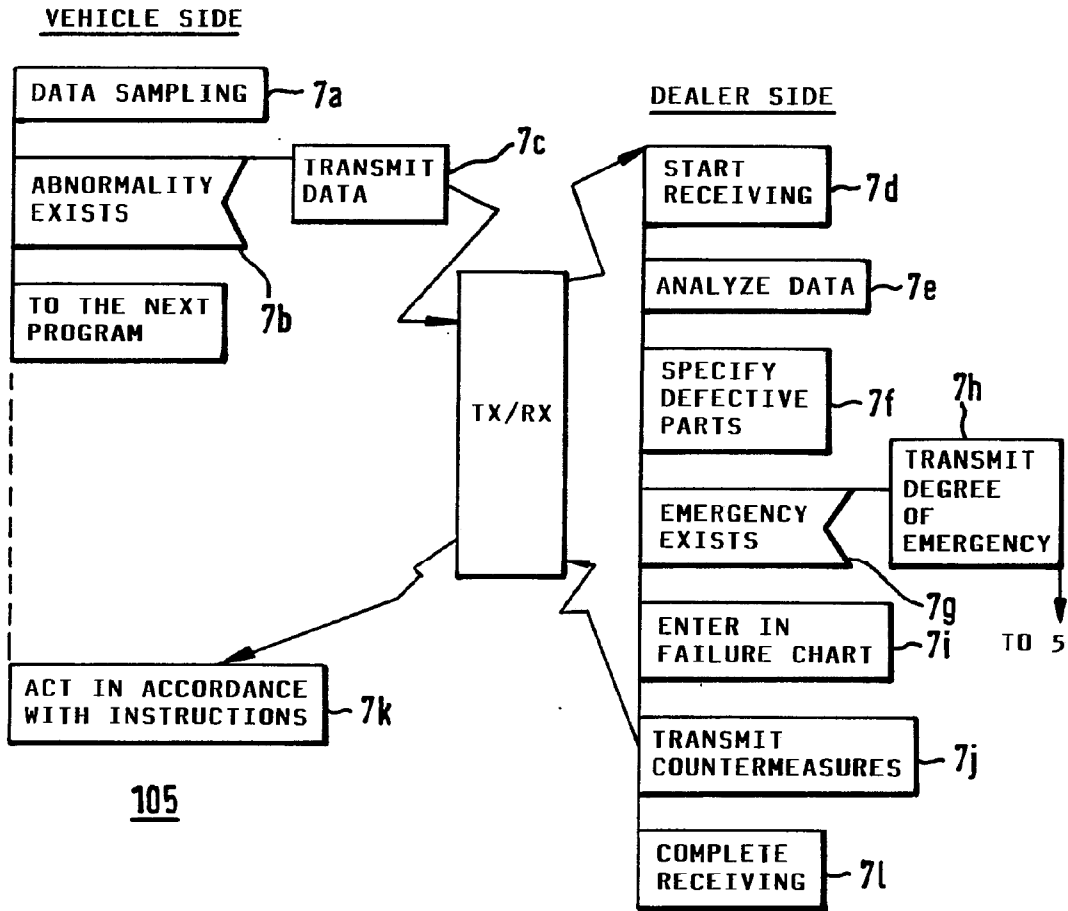

Fig.7

25

.....
.....
.....

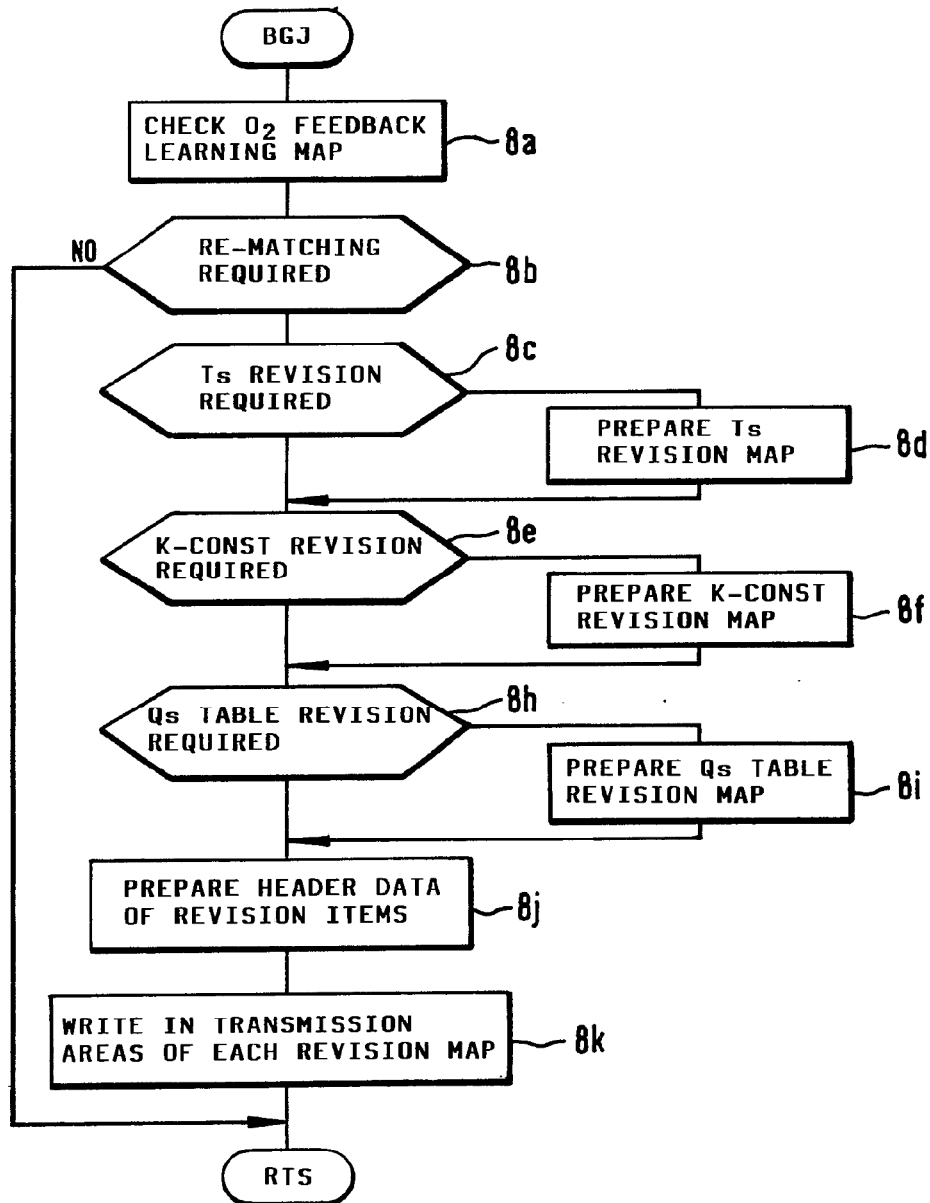

Fig. 8

Not classified / New /
reprovement deposit

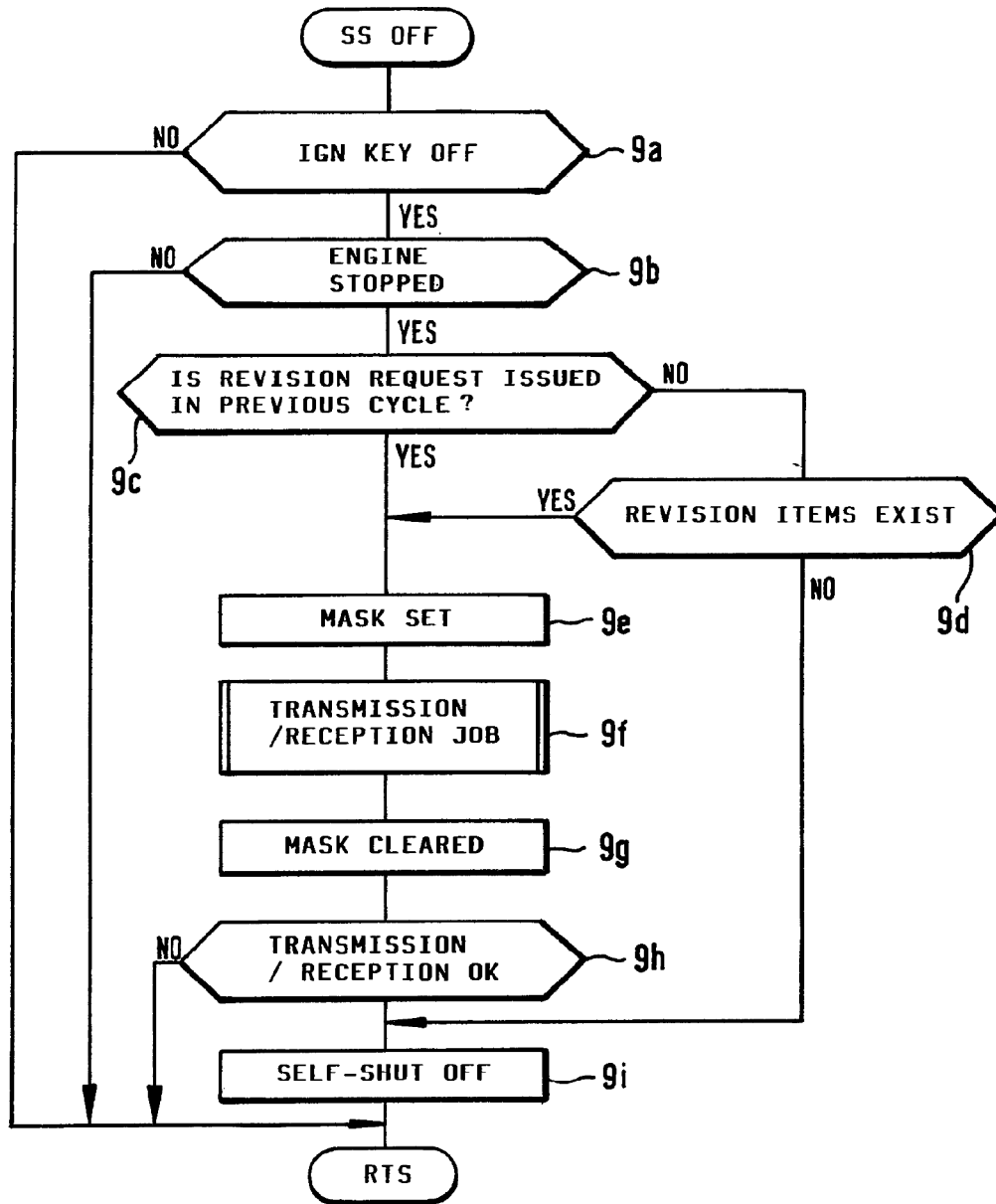

Fig. 9

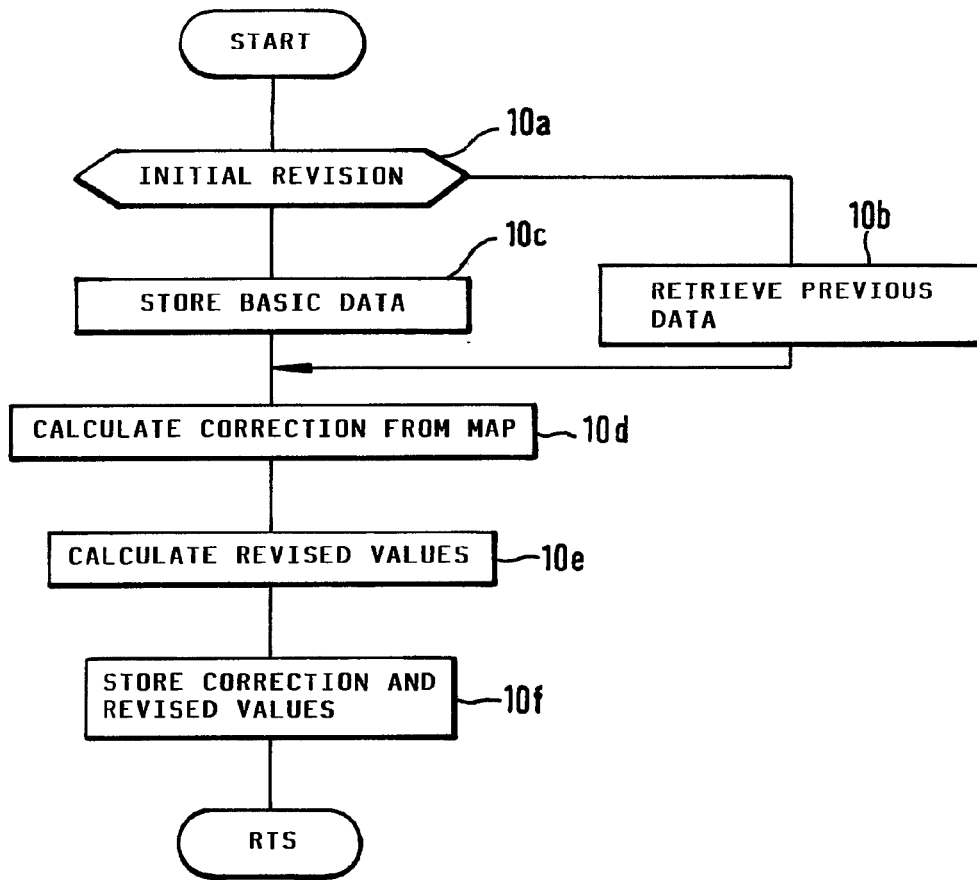

Fig. 10

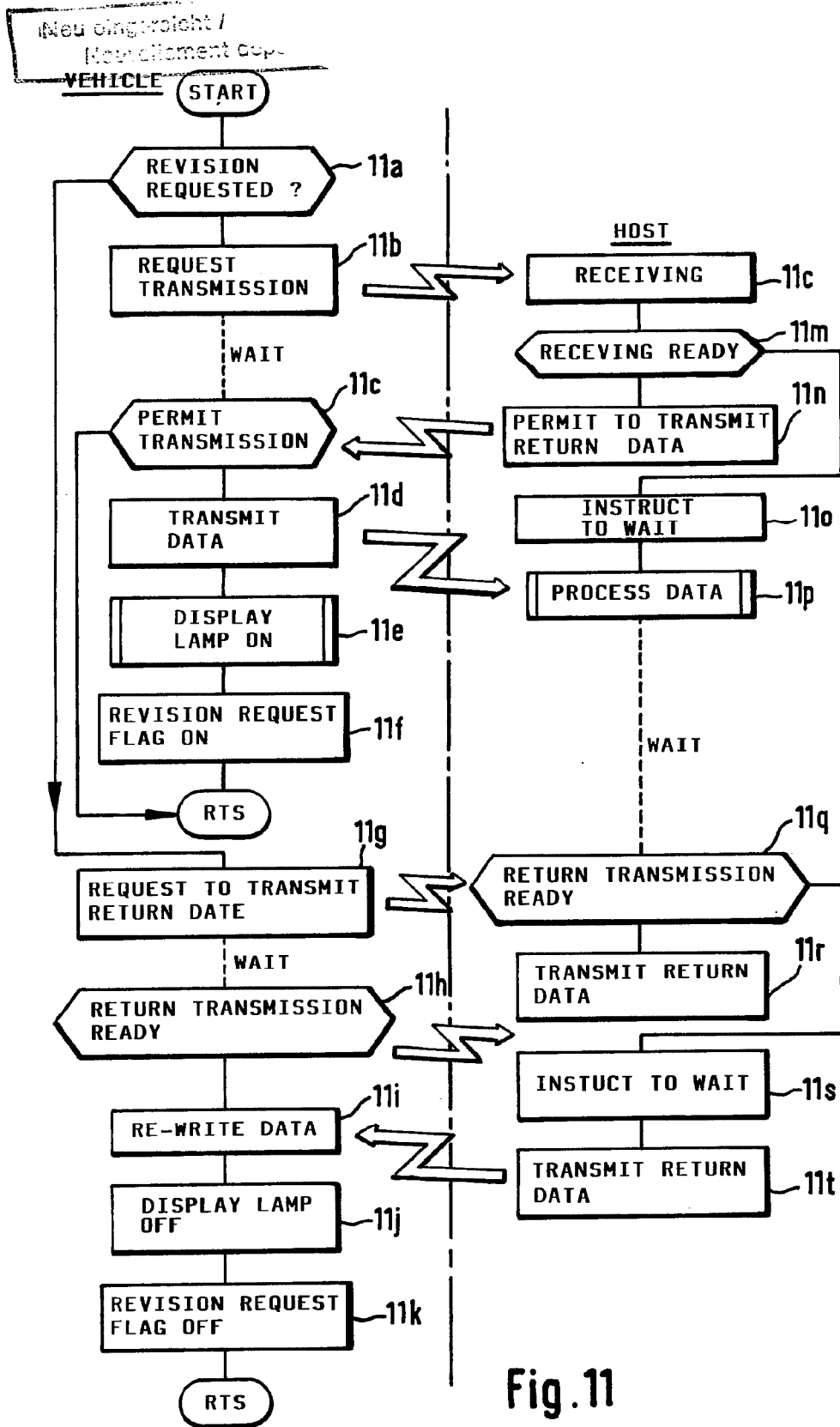

Fig. 11



Europäisches Patentamt
 European Patent Office
 Office européen des brevets



Publication number: **0 444 738 A2**

(12)

EUROPEAN PATENT APPLICATION

(21) Application number: **91200359.7**

(51) Int. Cl.⁵: **G01S 5/14, G01S 5/00**

(22) Date of filing: **20.02.91**

(30) Priority: **28.02.90 GB 9004433**

(43) Date of publication of application:
04.09.91 Bulletin 91/36

(84) Designated Contracting States:
DE FR GB

(71) Applicant: **PHILIPS ELECTRONIC AND ASSOCIATED INDUSTRIES LIMITED**
 Philips House 188 Tottenham Court Road
 London W1P 9LE(GB)
GB

Applicant: **N.V. Philips' Gloeilampenfabrieken**
 Groenewoudseweg 1
 NL-5621 BA Eindhoven(NL)
DE FR

(72) Inventor: **Barnard, Michael Edwin**
 c/o PHILIPS RESEARCH LABORATORIES
 Redhill, Surrey RH1 5HA(GB)

(74) Representative: **Moody, Colin James et al**
 PHILIPS ELECTRONICS Patents and Trade
 Marks Department Philips House 188
 Tottenham Court Road
 London W1P 9LE(GB)

(54) **Vehicle location system.**

(97) Signals from a number of NAVSTAR global positioning system (GPS) satellites (11,12,13,14) are received by a receiver (16) in a vehicle (15) and a segment of the signals is stored in a memory (18) prior to retransmission by a transmitter (19). A base station (35) receives these transmissions from the mobile unit using a first receiver (36) as well as receiving signals directly from the NAVSTAR GPS satellites (11,12,13,14) using a second receiver (38). A control and calculating means (37) within the base station (35) can determine the ephemeris (course) information for the satellites and measure the transmission times or propagation delays of signals between the satellites and the vehicle and with this information the control and calculating means (37) can calculate the position of the vehicle unit.

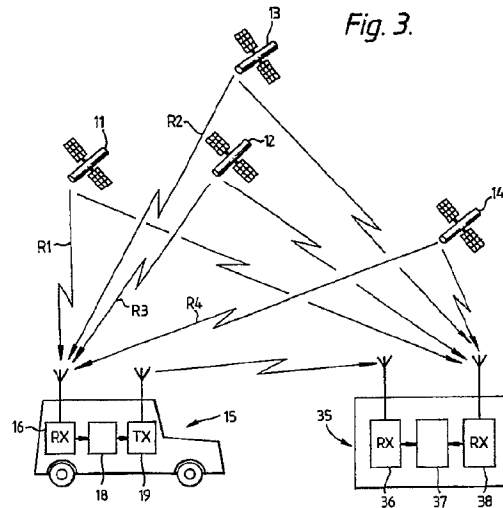

EP 0 444 738 A2

This invention relates to a vehicle location system which makes use of a satellite-based global positioning service (GPS) of the NAVSTAR type and which has particular but not exclusive application to an automatic vehicle location (AVL) system for use with a fleet of vehicles, each of which is in radio contact with a base station.

Fleets of vehicles such as messengers and taxis have traditionally kept a base station informed of their location by using speech messages from the vehicle over a radio link to an operator or controller at the base station. This technique has significant disadvantages which include errors due to mis-heard messages, distraction of the vehicle driver and the large amount of time that the operator has to spend in simply updating a map or schedule. One solution to this problem involves using an automated vehicle locating system based on the NAVSTAR satellite-based global position system (GPS).

The NAVSTAR GPS is described in "Global Positioning by Satellite" by Philip G. Mattos, Electronics and Wireless World, February 1989 but the salient points of the system are repeated here. The NAVSTAR GPS consists of a number of satellites in approximately 12 hour, inclined orbits of the earth, each satellite transmitting continuous positional information. Two positioning services are provided by NAVSTAR, the precise positioning service (PPS) which is reserved for military use and the standard positioning service (SPS) which is available for general use. The following description is confined to the SPS although some features are common to both systems. By measuring the propagation time of these transmissions and hence the distance from three satellites to himself, a user can make an accurate calculation of his position in three dimensions. To make a valid positional fix, the user needs to measure the propagation times to an accuracy of better than 100ns and to facilitate this the satellite signals each have timing marks at approximately 1 μ s intervals. However, each satellite's signals are synchronised to an atomic clock and the normal user of the system will not maintain such an accurate clock. As a result the user's clock is said to be in error (in other words, different from satellite time) by a clock bias C_B . By measuring the apparent satellite signal propagation times from four satellites rather than three, the redundancy can be used to solve for C_B and the three accurate propagation times required can be calculated. The signal propagation times correspond to ranges of the user from the satellites related by the speed of light c . Prior to correction for the user's clock bias C_B , the apparent ranges of the satellites are all in error by a fixed amount and are called pseudoranges.

Figure 1 of the accompanying drawings shows

a radio receiver 16 in a user's vehicle 15 receiving signals from four GPS satellites 11, 12, 13 and 14. The four pseudoranges of the satellite signals are denoted R1, R2, R3 and R4. The positions of the satellites and the vehicle are shown as three-dimensional coordinates whose origin is the centre of the earth. Figure 2 of the accompanying drawings shows the equations used by a GPS receiver to calculate the dimensional coordinates and the clock bias from a knowledge of four satellite positions and their respective pseudoranges. While it is not essential, these equations are usually solved using numerical techniques to hasten the calculations. It is important to note that the clock bias C_B has the dimension metres in order to agree with the remainder of the equation. C_B can be converted to a time by division by the speed of light c .

The data transmitted by each satellite consists broadly of three sets of information, the ephemeris, the almanac and the clock correction parameters. The ephemeris consists of detailed information about the satellite's own course over the next two hours, the almanac consists of less detailed information about the complete satellite constellation for a longer period and the clock correction parameters allow the user to correct for the GPS satellite's own clock errors. The satellite transmissions consist of a direct sequence spread spectrum (DSSS) signal containing the ephemeris, almanac, and the clock correction information at a rate of 50 bits per second (bps). In the case of the SPS a pseudo random noise (PRN) signal which has a chip rate of 1.023MHz and which is unique to each satellite is used to spread the spectrum of the information, which is then transmitted on a centre frequency of 1575.42MHz. The PRN signal is known as a coarse/acquisition (C/A) code since it provides the timing marks required for fast acquisition of GPS signals and coarse navigation. The signals received at a user's receiver have a bandwidth of approximately 2MHz and a signal to noise ratio (S/N) of approximately -20dB. In addition, since the satellites are each moving at a speed in excess of 3km/s, the GPS signals are received with a Doppler frequency offset from the GPS centre frequency. As a result, a stationary GPS receiver has to be capable of receiving signals with frequencies of up to ± 4 KHz from the GPS centre frequency, and a mobile receiver (as is usually the case) has to be able to receive signals over an even greater frequency range. To recover the data and measure the propagation time of the satellite signals, the GPS receiver must cancel or allow for the Doppler frequency offset and generate the C/A code relevant to each satellite. Initially, at least, this can be very time consuming since to despread the DSSS signals, the incoming and locally generated PRN codes must be exactly at synchronism. To

find the PRN code delay the receiver must compare the locally generated code and the incoming code at a number of different positions until the point of synchronism or correlation is found. With a code length of 1023 chips this comparison can be a lengthy procedure. However, once the frequency offset and the PRN code delay for each satellite are known, tracking them is relatively easy.

Some considerable effort has been directed towards making more accurate location systems using the GPS. One technique for obtaining improved accuracy is to use a differential system which makes propagation time measurements for a mobile receiver and for a fixed receiver at a known location. Patent specification WO 87/06713 describes such a differential system which additionally smooths the values of propagation time over a number of measurements to obtain improved accuracy. There are numerous applications of the GPS, however, which do not require pinpoint accuracy; the operator of a fleet of vehicles, for example, will probably be satisfied with locations having an accuracy of only several hundred metres.

As can be appreciated, a receiver for use with the GPS is rather complex and hence expensive and it is the aim of the present invention to provide a considerably simplified system, based on the GPS, for locating a distant vehicle or vehicles from a fixed point.

According to a first aspect of the present invention there is provided a vehicle location system for use in a global positioning system (GPS), comprising at least one vehicle mounted equipment including means for receiving signals directly from the GPS, a fixedly sited base station including first means for receiving signals directly from the GPS, characterised in that the or each vehicle mounted equipment includes means for recording the received GPS signals and means for retransmitting the recorded GPS signals to the base station, and in that the fixedly sited base station includes second means for receiving the recorded GPS signals retransmitted by the vehicle mounted equipment, and position determining means coupled to the first and second means, for determining the position of the or each vehicle at the time when the vehicle mounted equipment received the GPS signals.

The maximum rate at which the retransmission of the GPS signals takes place will be determined by the capacity of the radio channel between the mobile unit(s) and the base station(s). This retransmission rate will generally be somewhat lower than the original rate of the GPS signals and at a different carrier frequency.

It is envisaged that a vehicle location system in accordance with the present invention will make use of a vehicle mounted communications transmitter that is already a part of the vehicle's equipment

and also serves one or more other purposes although this is by no means essential.

The vehicle mounted equipment can make the necessary recordings of GPS data on receipt of a request signal from a base station, at predetermined intervals, or continuously, using a first in, first out (FIFO) type of storage means. The data can be retransmitted on receipt of a request signal from a base station, upon the lapse of a given amount of time from the beginning of the recording of the data or at predetermined time intervals. To make a position fix the transition time of the satellite signals has to be known accurately and the redundancy available due to reception of four satellite signals will only resolve errors of up to a few milliseconds. A coarser measure of the signal arrival time, that is nonetheless accurate to within a few milliseconds will thus be required by the base station. One solution to this problem would be for the vehicle mounted equipment to transmit a time of arrival (TOA) signal with the recording of the satellite data. Another solution would be for the vehicle mounted equipment to record the satellite data at certain, known intervals and to retransmit the data before the commencement of the next interval. In most cases the vehicle mounted equipment will also transmit an identifying signal with the recorded satellite signals so that the base station has a knowledge of the origin of any particular signal. Where a specific mobile unit has been requested to retransmit its recorded data, this identification signal may be superfluous, but its inclusion does provide a degree of extra protection in the event of receipt of corrupted request signals from the base station.

According to a second aspect of the present invention there is provided a vehicle mounted equipment for use with a vehicle location system in accordance with to the first aspect of the present invention, including means for receiving GPS signals, characterised in that the equipment also includes means for recording the received GPS signals and means for retransmitting the recorded GPS signals.

According to a third aspect of the present invention there is provided a fixedly sited base station for use with the system in accordance with the first aspect of the present invention, including first means for receiving GPS signals directly from the GPS, characterised in that the base station also includes second means for receiving a retransmission of GPS signals from a vehicle mounted equipment and means coupled to said first and second means for determining the position of the vehicle mounted equipment at the time that the GPS signals were received.

The present invention will now be described, by way of example, with reference to Figures 3, 4

and 5 of the accompanying drawings, wherein:

Figure 3 shows signals from four NAVSTAR satellites being received by a mobile unit and retransmitted to a base station,

Figure 4 is a block schematic diagram of a receiver, data store and transmitter for a mobile unit, and

Figure 5 is a block schematic diagram of a GPS receiver, a transceiver and a data store in a base station.

In the drawings corresponding features have been identified using the same reference numerals.

Figure 3 shows the vehicle location system operating with just one vehicle 15 and one base station 35. Transmissions from NAVSTAR GPS satellites 11,12,13 and 14 are received by both a vehicle mounted receiver 16 and a base station receiver 38. The GPS signals received by mobile receiver 16 are fed to a storing and control means 18 which records a short section of the satellite signals. The control means 18 might record GPS signals at preset intervals, upon receipt of a request signal (not shown) from the base station, or continuously where the stored signals at any instant will be those most recently received. The recorded signals are then retransmitted, at a lower data rate and on a different carrier frequency to that used by the satellites, by a transmitter 19 to a receiver 36 in the base station. The signals could be retransmitted at a predetermined interval after the commencement of the recording or upon receipt of a request signal from the base station. In the former case it may be necessary for the retransmitted signal to include some kind of identifier so that the base station knows from which vehicle the signals have originated. The rate at which the signals are retransmitted will depend upon the capacity of the radio channel between the mobile unit and the base station but will be approximately 1,000 times less than the rate at which they were received and sampled if a voice channel is used. The received and recorded satellite signals have a S/N ratio of approximately -20dB and retransmission will probably not cause significant further deterioration of the S/N. As a result, it is not usually necessary to include any error detection or correction codes with the retransmitted data. The base station also includes means for receiving the GPS signals directly from the satellites using receiver 38. Signals from receiver 38 are passed to a processing means 37 which maintains a copy of the GPS ephemeris and clock correction data for those satellites currently in use by the system. The processing means 37 can, with the data received by receivers 36 and 38, calculate the position of the vehicle 15 by removing the Doppler offset frequency successively from each of the recorded satellite signals, correlating the relevant C/A code

with each of the signals and calculating the satellite pseudoranges. The processing means 37 may also maintain a copy of the GPS almanac so that the vehicle location system can use the signals from the most favourable satellites and find newly visible satellites more quickly.

Two main problems can arise from this offline, remote processing of the satellite signals. Firstly, if the mobile unit is at a great distance from the base station it is possible that the base station will not be able to receive signals from a satellite that is visible to the vehicle and which is essential to the positional fix. The base station will thus be deprived of up-to-date ephemeris information for that satellite. To reduce the likelihood of this problem, the antenna for the base station GPS receiver should be omnidirectional and mounted in an area clear of obstructions. Where a very large area is to be covered, the use of a number of physically separated base stations with means for intercommunication might be the best solution. For the base station to obtain the ephemeris data from the retransmission by the mobile unit is not a practical proposition since the recording and retransmission of sufficient spread spectrum data to provide a complete satellite ephemeris would take several hours. Secondly, there is a range ambiguity problem that, while present in a conventional vehicle mounted GPS receiver system, may be more difficult to solve in this case. The PRN codes used by the satellites repeat every millisecond and as a result the circular correlation of the received and locally generated PRN codes only allows a GPS receiver to calculate the sub-millisecond part of the satellite signal transit time. The integer number of milliseconds in the signal transit times can usually be calculated from the approximate position of the vehicle. Since a 1 millisecond difference in transit time corresponds to a difference in the satellite pseudorange of 300km, a knowledge of the vehicle position to within approximately 100km will allow the calculation of the integer number of milliseconds in the signal transit times. This degree of accuracy of the vehicle position may be available from a knowledge of which cell of a cellular radio system is being used to retransmit the signals to the base station. If the vehicle position is not known to this degree of accuracy (100km may be less than one hour's motoring) the data bit edges on the satellite signals can act as timing marks with a spacing of 20ms. Since the modulation of the satellite signal by the data is synchronised to an atomic clock, the position of the data bit edges in the received, despread signals gives a coarse measure of transit time which is nonetheless accurate to within one millisecond. To use this measurement technique, at least 20ms of satellite signals will need to be recorded to ensure that the recording

contains a data bit edge from each satellite. A third alternative is to use the Doppler shift on the received GPS signals to calculate an approximate user position. However, this method still requires at least 20ms of satellite data and is mathematically more complex, especially if the user's vehicle is in motion.

Figure 4 is a block schematic diagram of a mobile receiver and transmitter suitable for use in a vehicle locating system in accordance with the present invention. Satellite signals are received at an antenna 20 which feeds an rf amplifier 22. The input stage of the rf amplifier 22 will usually include a bandpass filter. The output of the amplifier 22 is mixed with the output of local oscillator 24 in a mixer 23 and the output of the mixer is filtered by a bandpass filter 26. Although only one down-conversion stage is shown, the front end of the receiver could include two or more such stages. The nominal intermediate frequency to which the satellite signals are mixed down could be anything from zero to several MHz. In the case of a zero IF receiver, the filter 26 would be a low pass type. The output of filter 26 is digitised in an analogue to digital converter 27 whose sampling rate is determined by the Nyquist sampling criterion.

The output of the analogue to digital converter 27 is stored in a random access memory (RAM) 28 which is addressed by a counter 31, the counter itself being under the control of a receiver controller 30. The size of this RAM will be determined by the rate of sampling and the length of time that the incoming satellite signals are to be recorded for. For example, sampling at 2.048MHz (to satisfy the Nyquist criterion) for 8ms will require just under 16kbits of memory. The contents of the RAM 28 are transmitted serially by transmitter 32 via antenna 33. In a practical system the transmitter 32 may be part of an existing transceiver within the mobile unit.

These signals are received and processed by the base station, an embodiment of which is shown in block schematic form in Figure 5. The retransmitted signals from the mobile unit are received by antenna 43 and fed to a transceiver 44. Again, the transceiver 44 could be part of an existing communications link. A base station controller 42 is connected to the transceiver and in addition to receiving the signals from the mobiles and calculating their positions it maintains an up to date copy of the ephemeris data for all the satellites currently in view. GPS signals are received by a GPS receiver 38 via an antenna 40. The purpose of this receiver is to decode satellite ephemeris and clock correction data and it will probably also decode almanac data to facilitate satellite signal acquisition. Since positional information is not required for the base station it does not need to determine the propaga-

tion delays of the GPS signals. It is thus possible to use a signal despreading technique based on non-coherent demodulation which does not use any locally generated C/A codes. In all other respects the satellite data is received as described previously for a conventional system and stored in a RAM 41 for use by the base station controller 42 in calculating the satellite pseudoranges in respect of the or each vehicle. One advantage of using a complete GPS receiver at the base station rather than one employing a non-coherent demodulation technique is that it permits location fixes to be made by a differential technique. The base station uses the GPS to determine its own position and, since this is already known accurately, can calculate an up to date error term for the GPS. When the mobile unit(s) position is calculated, this error can be removed from the mobile unit's pseudoranges which gives an improvement in the accuracy of the positional fix. The transceiver 44 enables request signals to be passed from the base station to the mobile units for commencement of data logging and/or data transmission. It can also, if required, relay vehicle position or directions back to the driver of the vehicle.

From reading the present disclosure other modifications will be apparent to persons skilled in the art. Such modifications may involve other features which are already known in the design, manufacture and use of GPS systems and component parts thereof and which may be used instead of or in addition to features already described herein. Although claims have been formulated in this application to particular combinations of features, it should be understood that the scope of the disclosure of the present application also includes any novel feature or any novel combination of features disclosed herein either explicitly or implicitly or any generalisation thereof, whether or not it relates to the same invention as presently claimed in any claim and whether or not it mitigates any or all of the same technical problems as does the present invention. The applicants hereby give notice that new claims may be formulated to such features and/or combinations of such features during the prosecution of the present application or of any further application derived therefrom.

Claims

1. A vehicle location system for use in a global positioning system (GPS), comprising at least one vehicle mounted equipment including means for receiving signals directly from the GPS, a fixedly sited base station including first means for receiving signals directly from the GPS, characterised in that the or each vehicle mounted equipment includes means for re-

recording the received GPS signals and means for retransmitting the recorded GPS signals to the base station, and in that the fixedly sited base station includes second means for receiving the recorded GPS signals retransmitted by the vehicle mounted equipment, and position determining means coupled to the first and second means, for determining the position of the or each vehicle at the time when the vehicle mounted equipment received the GPS signals.

- 2. A vehicle location system as claimed in Claim 1, characterised in that the vehicle mounted equipment transmits a time of arrival (TOA) signal in addition to retransmitting the recorded GPS signals. 5
- 3. A vehicle location system as claimed in Claim 1 or Claim 2, characterised in that the rate at which the vehicle mounted equipment retransmits the GPS signals is lower than that at which the signals were recorded. 10
- 4. A vehicle location system as claimed in Claim 1, Claim 2 or Claim 3, characterised in that the vehicle mounted equipment further comprises control means coupled to the recording means, and in that signals from the control means cause the recording means to record GPS signals at preset intervals. 15
- 5. A vehicle location system as claimed in any one of the Claims 1 to 4, characterised in that the GPS is the satellite-based NAVSTAR GPS, and in that the or each base station has means for obtaining the GPS ephemeris for the satellites in use. 20
- 6. A vehicle location system as claimed in Claim 5, characterised in that the means for obtaining the GPS ephemeris in the or each base station has means for despreading the NAVSTAR GPS signals without using any locally generated pseudo random noise codes. 25
- 7. A vehicle mounted equipment for use with the system as claimed in any one of the Claims 1 to 6, including means for receiving GPS signals, characterised in that the equipment also includes means for recording the received GPS signals and means for retransmitting the recorded GPS signals. 30
- 8. A vehicle mounted equipment for use with the system as claimed in Claim 2 or any Claim dependent thereon, including means for receiving GPS signals, characterised in that the 35

equipment includes means for recording the received GPS signals and means for retransmitting the recorded GPS signals and a time of arrival (TOA) signal.

- 9. A fixedly sited base station for use with the system as claimed in any one of the Claims 1 to 6, including first means for receiving GPS signals directly from the GPS, characterised in that the base station also includes second means for receiving a retransmission of GPS signals from a vehicle mounted equipment and means coupled to said first and second means for determining the position of the vehicle mounted equipment at the time that the GPS signals were received. 40
- 10. A fixedly sited base station as claimed in Claim 9, characterised in that the means for determining the position of the vehicle mounted equipment calculates the position of the base station using the GPS and then calculates the position of the vehicle mounted equipment using a differential technique. 45

Fig. 1.

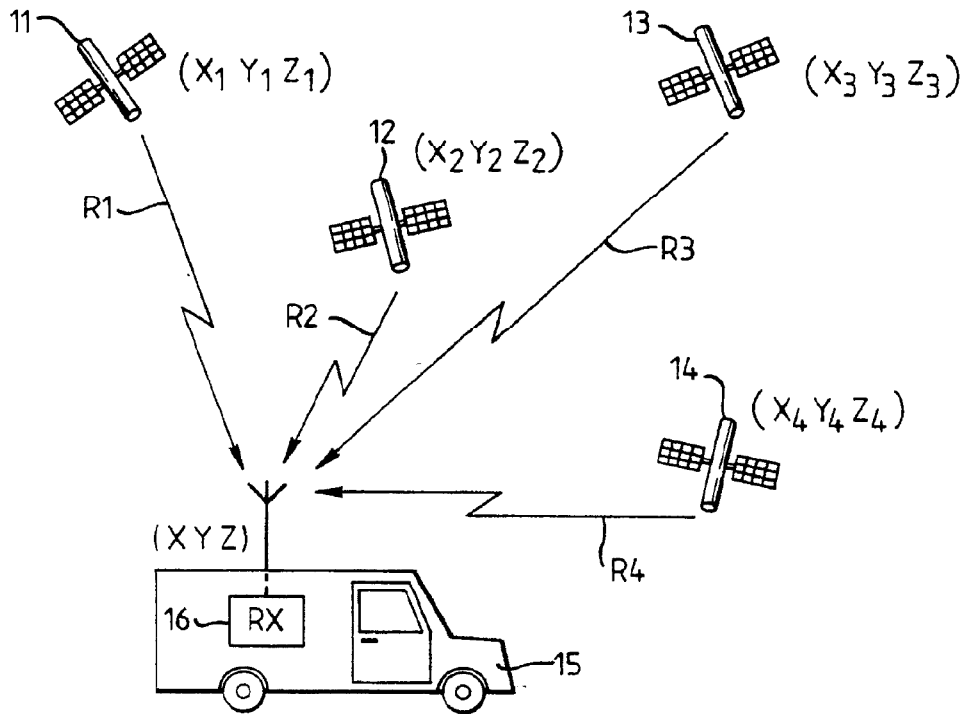

Fig. 2.

$$\begin{aligned} (X_1 - X)^2 + (Y_1 - Y)^2 + (Z_1 - Z)^2 &= (R_1 - C_B)^2 \\ (X_2 - X)^2 + (Y_2 - Y)^2 + (Z_2 - Z)^2 &= (R_2 - C_B)^2 \\ (X_3 - X)^2 + (Y_3 - Y)^2 + (Z_3 - Z)^2 &= (R_3 - C_B)^2 \\ (X_4 - X)^2 + (Y_4 - Y)^2 + (Z_4 - Z)^2 &= (R_4 - C_B)^2 \end{aligned}$$

Fig. 3.

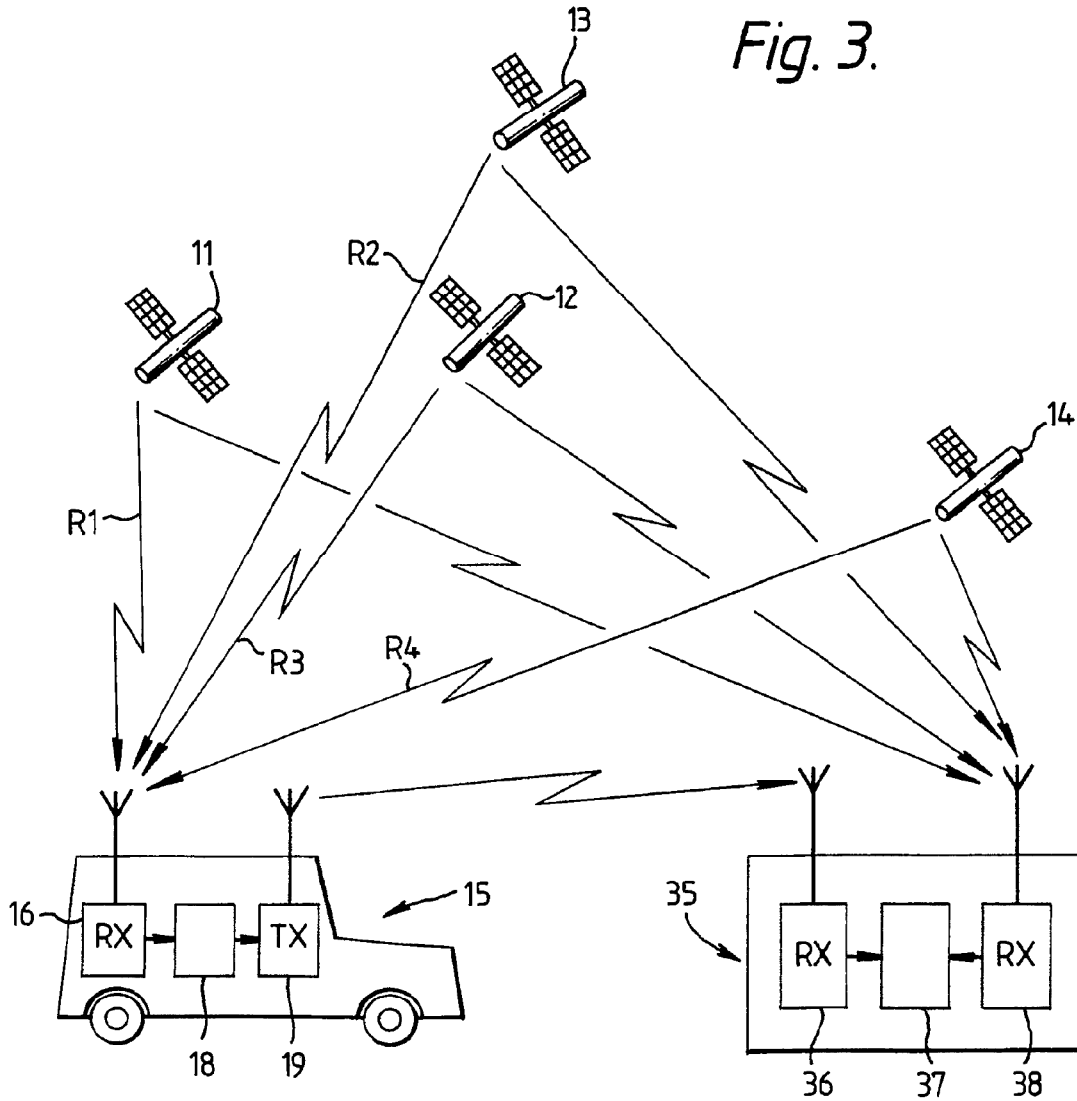

Fig. 4.

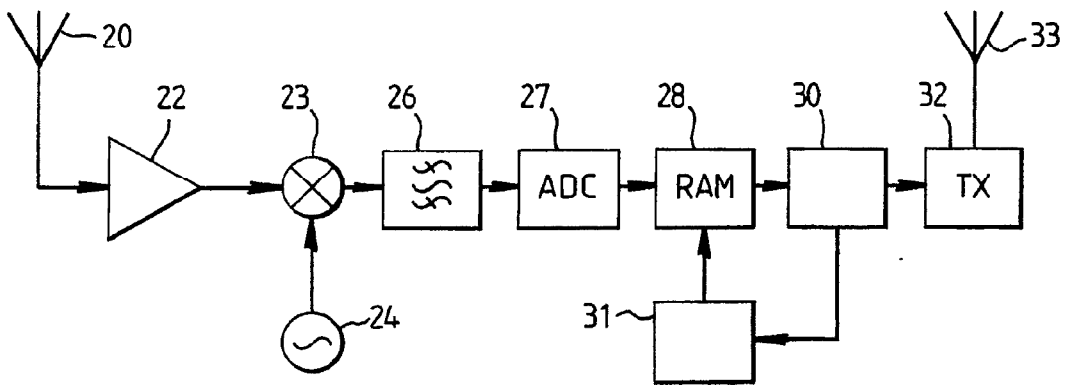
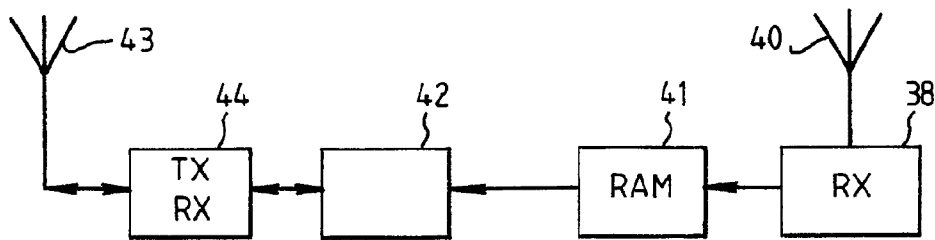

Fig. 5.



Individual evaluation system for motorcar risk

AB

(EP-700009)







The vehicle carries an electronic data processor linked to a speedometer, accelerometer, internal clock and calendar for checking and recording types of traffic hazard, duration of journey and other data related to safety. It can receive electromagnetic signal from the roadside related e.g. to speed limits, icing conditions and traffic jams, and can exchange data by wireless communication with a service station.

IN MINGUIJON PEREZ SALVADOR

PA MINGUIJON PEREZ SALVADOR

PA0 Minguijon Perez, Salvador; C/ Marcial no. 4, Pral B. Izqda; E-50005 Zaragoza (ES)

Published As

	Publ. number	Pub. date	Appl. number	Appl. date	Publ. Stage
	EP0700009	19960306	1995EP-0500123	19950828	A2 - Application published without search report
	EP0700009	19971112			A3 - Search report
	ES2108613	19971216	1994ES-0001925	19940901	A1 - Pat. application published with search report
	ES2108613	19980801			B1 - Patent published with search report
	EP0700009	20010321			B1 - Patent specification
	DE59509105	20010426	1995DE-5009105	19950828	D1 - Granted EP number in Bulletin

PR

1994ES-0001925 19940901

IC

G06F-017/60
G06Q-040/00
G06Q-099/00
G07C-005/08
G07C-005/10

ICAA

G06Q-040/00 [2006-01 A - I R M EP];
G06Q-099/00 [2006-01 A - I R M EP]

ICCA

G06Q-040/00 [2006 C - I R M EP];
G06Q-099/00 [2006 C - I R M EP]

EC

G06Q-040/00D
G06Q-099/00

CT

(EP-700009)

Search Report [Examiner]

FR2533049(A1)(Cat. X) [FR2533049]

FR2647930(A1)(Cat. Y) [FR2647930]

US5046007(A)(Cat. A) [US5046007]

BE1000765(A6)(Cat. A) [BE1000765]

WO9002388(A1)(Cat. A) [WO9002388]

(ES2108613)

Search Report [Examiner]

GB2268608(A)(Cat. Y) [GB2268608]

EP0517331(A1)(Cat. Y) [EP-517331]

GB2266803(A)(Cat. A) [GB2266803]

FR2533049(A1)(Cat. A) [FR2533049]

WO9002388(A1)(Cat. A) [WO9002388]

JP5052608(A)(Cat. A) [JP5052608]

REF

(ES2108613)

Search Report references [Examiner]

-PATENT ABSTRACTS OF JAPAN, CD-ROM PAJ N[<control>] 49, G01B-L, 1988-1993 (2/2) & JP 5052608 A (MAZDA MOTOR CORP.) 02.03.93

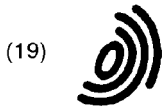

Europäisches Patentamt
European Patent Office
Office européen des brevets



(11) **EP 0 700 009 A3**

(12) **EUROPÄISCHE PATENTANMELDUNG**

(88) Veröffentlichungstag A3:
12.11.1997 Patentblatt 1997/46

(51) Int Cl.⁶: **G06F 17/60, G07C 5/08**

(43) Veröffentlichungstag A2:
06.03.1996 Patentblatt 1996/10

(21) Anmeldenummer: **95500123.5**

(22) Anmeldetag: **28.08.1995**

(84) Benannte Vertragsstaaten:
DE FR GB IT

(71) Anmelder: **Minguijon Perez, Salvador**
50005 Zaragoza (ES)

(30) Priorität: **01.09.1994 ES 9401925**

(72) Erfinder: **Minguijon Perez, Salvador**
50005 Zaragoza (ES)

(54) **Individuelle-Bewertungssystem für das Risiko an selbstangetrieben Fahrzeuge**

(57) Unter die Individuelle-Bewertungssystem für das Risiko an selbstangetrieben-Fahrzeuge stellt sich ein Handlungsweise und elektronisches-Einrichtung vor, die die persönliches Versicherungsprämie in Funktion des übernehmendes wirkliches Risiko-Schätzung

erlaubt, in Basis nach die bestehende Wechselbeziehungen berechnet zwischen dieses und messbar Parameter im eigenen Fahrzeug.

Man stellt ein strategisches-Betriebs Einführung-Profil vor.

EP 0 700 009 A3



Europäisches
Patentamt

EUROPÄISCHER RECHERCHENBERICHT

Nummer der Anmeldung
EP 95 50 0123

EINSCHLÄGIGE DOKUMENTE			
Kategorie	Kennzeichnung des Dokuments mit Angabe, soweit erforderlich, der maßgeblichen Teile	Betrifft Anspruch	KLASSIFIKATION DER ANMELDUNG (Int.Cl.6)
X	FR 2 533 049 A (MALON) 16.März 1984 * Seite 2, Zeile 2 - Zeile 5 * * Seite 2, Zeile 33 - Seite 3, Zeile 2 *	1,2	G06F17/60 G07C5/08
Y	* Seite 5, Zeile 11 - Zeile 35 * * Seite 13, Zeile 6 - Zeile 9 *	3-10	
Y	FR 2 647 930 A (CGA) 7.Dezember 1990 * Seite 4, Zeile 11 - Zeile 35 * * Seite 5, Zeile 19 - Zeile 21 *	3-10	
A	US 5 046 007 A (MCCRERY ET AL) 3.September 1991 * Spalte 6, Zeile 32 - Zeile 39 * * Spalte 9, Zeile 13 - Zeile 23 * * Spalte 10, Zeile 62 - Spalte 11, Zeile 14 *	1-5,7,8,10	
A	BE 1 000 765 A (STELLAR INTERNATIONAL) 28.März 1989 * Seite 4, Zeile 26 - Zeile 29 *	1	
A	WO 90 02388 A (NORWEGIAN BIOTRONICS) 8.März 1990 * Seite 1, Zeile 7 - Zeile 17 *	1,2,7	RECHERCHIERTE SACHGEBIETE (Int.Cl.6) G06F G01R G07C
Der vorliegende Recherchenbericht wurde für alle Patentansprüche erstellt			
Recherchenort	Abschließdatum der Recherche		Prüfer
DEN HAAG	9.September 1997		Pottiez, M
KATEGORIE DER GENANNTEN DOKUMENTE		T : der Erfindung zugrunde liegende Theorien oder Grundsätze E : älteres Patentdokument, das jedoch erst am oder nach dem Anmeldedatum veröffentlicht worden ist D : in der Anmeldung angeführtes Dokument I : aus anderen Gründen angeführtes Dokument & : Mitglied der gleichen Patentfamilie, übereinstimmendes Dokument	
X : von besonderer Bedeutung allein betrachtet Y : von besonderer Bedeutung in Verbindung mit einer anderen Veröffentlichung derselben Kategorie A : technologischer Hintergrund O : nichtschriftliche Offenbarung P : Zwischenliteratur			

EPO FORM 1503 01.92 (PWA/CCH)



(12) EUROPEAN PATENT APPLICATION

(88) Date of publication A3:
 12.02.2003 Bulletin 2003/07

(51) Int Cl.7: G06F 17/60

(43) Date of publication A2:
 03.02.1999 Bulletin 1999/05

(21) Application number: 98304989.1

(22) Date of filing: 25.06.1998

(84) Designated Contracting States:
 AT BE CH CY DE DK ES FI FR GB GR IE IT LI LU
 MC NL PT SE
 Designated Extension States:
 AL LT LV MK RO SI

(72) Inventors:
 • Cullen, Terence David
 Nr Stockbridge, Hants S020 8HT (GB)
 • Neill, James Patrick
 Slough, Berks SL1 2HR (GB)

(30) Priority: 18.09.1997 GB 9719844
 02.08.1997 GB 9716290

(74) Representative: Guyatt, Derek Charles et al
 Fujitsu Services Limited
 Observatory House
 Windsor Road
 Slough Berkshire SL1 2EY (GB)

(54) Computer system for delivery of financial services

(57) A computer system is provided for delivery of financial services, such as banking, general insurance, life assurance, pensions and investments, loans and mortgages, and financial planning and advisory services. The system comprises a number of user computers connected to a plurality of server computers by way of

a network, such as the Internet. The system creates at least one mobile agent which obtains details of a user's requirements, obtains financial information from the server computers on behalf of the user in the light of the user's requirements, and then transports itself to the user's computer to deliver the financial information to the user.

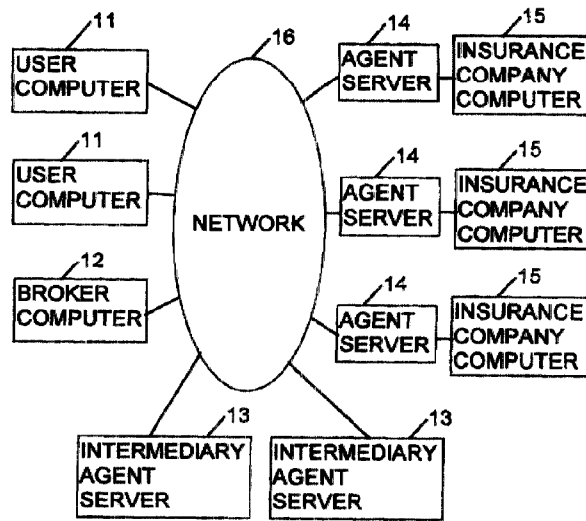

FIG. 1

EP 0 895 173 A3

European Patent
Office

EUROPEAN SEARCH REPORT

Application Number
EP 98 30 4989

DOCUMENTS CONSIDERED TO BE RELEVANT			
Category	Citation of document with indication, where appropriate, of relevant passages	Relevant to claim	CLASSIFICATION OF THE APPLICATION (Int.Cl.6)
Y	FARMER W M ET AL: "Security for mobile agents: Issues and Requirements", NATIONAL INFORMATION SYSTEMS SECURITY CONFERENCE, XX, XX, PAGE(S) 591-597 XP002165465 ^ page 592, column 2, line 1, paragraph 4 - page 593, column 1, line 12, paragraph 2 *	1-7,10	G06F17/60
Y	TAKAHASHI K ET AL: "COLLECTING SHOP AND SERVICE INFORMATION WITH SOFTWARE AGENTS", PROCEEDINGS OF THE INTERNATIONAL CONFERENCE ON THE PRACTICAL APPLICATION OF INTELLIGENT AGENTS AND MULTI-AGENT TECHNOLOGY, XX, XX, PAGE(S) 587-595 XP001088826 * abstract *	1-7,10	
Y	DOORENBOS R B ET AL: "A SCALABLE COMPARISON-SHOPPING AGENT FOR THE WORLD-WIDE WEB", PROCEEDINGS OF THE FIRST INTERNATIONAL CONFERENCE ON AUTONOMOUS AGENTS MARINA DEL REY, CA., FEB. 5 - 8, 1997, PROCEEDINGS OF THE INTERNATIONAL CONFERENCE ON AUTONOMOUS AGENTS, NEW YORK, ACM, US, VOL. CONF. 1, PAGE(S) 39-48 XP000915342 ISBN: 0-89791-877-0 * page 40, column 1, line 2 - page 40, column 2, line 17 *	1-7,10	TECHNICAL FIELDS SEARCHED (Int.Cl.6) G06F
Y	US 4 831 526 A (ALEXANDER BERNICE ET AL) 16 May 1989 (1989-05-16) * the whole document *	1-7,10	
-/--			
The present search report has been drawn up for all claims			
Place of search MUNICH		Date of completion of the search 12 December 2002	Examiner May, M
CATEGORY OF CITED DOCUMENTS X : particularly relevant if taken alone Y : particularly relevant if combined with another document of the same category A : technological background O : non-written disclosure P : intermediate document		T : theory or principle underlying the invention E : earlier patent document, but published on, or after the filing date D : document cited in the application L : document cited for other reasons & : member of the same patent family, corresponding document	

EPO FORM 1502 03.02 (P04/C01)



European Patent
Office

EUROPEAN SEARCH REPORT

Application Number
EP 98 30 4989

DOCUMENTS CONSIDERED TO BE RELEVANT			
Category	Citation of document with indication, where appropriate, of relevant passages	Relevant to claim	CLASSIFICATION OF THE APPLICATION (Int.Cl.6)
Y	ETZIONI O ET AL: "INTELLIGENT AGENTS ON THE INTERNET: FACT, FICTION, AND FORECAST", IEEE EXPERT, IEEE INC. NEW YORK, US, VOL. 10, NR. 4, PAGE(S) 44-49 XP000541232 ISSN: 0885-9000 * the whole document *	1-7,10	
Y	PERKOWITZ M ET AL: "LEARNING TO UNDERSTAND INFORMATION ON THE INTERNET: AN EXAMPLE-BASED APPROACH", JOURNAL OF INTELLIGENT INFORMATION SYSTEMS: ARTIFICIAL INTELLIGENCE AND DATABASE TECHNOLOGIES, KLUWER ACADEMIC PUBLISHERS, AMSTERDAM, NL, VOL. 8, NR. 2, PAGE(S) 133-153 XP000933994 ISSN: 0925-9902 * the whole document *	1-7,10	
Y	ROESLER M ET AL: "INTELLIGENT AGENTS", ONLINE, ONLINE, WESTON, CT, US, VOL. 18, NR. 4, PAGE(S) 1-13 XP002940099 ISSN: 0146-5422 * the whole document *	1-7,10	
E	WO 98 32289 A (UNIV WASHINGTON) 23 July 1998 (1998-07-23) * the whole document *	1-7,10	
A	CHEN Q ET AL: "DYNAMIC SOFTWARE AGENTS FOR BUSINESS INTELLIGENCE APPLICATIONS", PROCEEDINGS OF THE 2ND INTERNATIONAL CONFERENCE ON AUTONOMOUS AGENTS MINNEAPOLIS/ST.PAUL, MN, MAY 9 - 13, 1998, PROCEEDINGS OF THE INTERNATIONAL CONFERENCE ON AUTONOMOUS AGENTS, NEW YORK, NY: ACM, US, PAGE(S) 453-454 XP002951490 ISBN: 0-89791-983-1 * the whole document *		
The present search report has been drawn up for all claims			
Place of search MUNICH		Date of completion of the search 12 December 2002	Examiner May, M
CATEGORY OF CITED DOCUMENTS X : particularly relevant if taken alone Y : particularly relevant if combined with another document of the same category A : technological background O : non-written disclosure P : intermediate document		T : theory or principle underlying the invention E : earlier patent document, but published on, or after the filing date D : document cited in the application L : document cited for other reasons 8 : member of the same patent family, corresponding document	

EPC FORM 1503 03.02 (IP/C01)

**ANNEX TO THE EUROPEAN SEARCH REPORT
ON EUROPEAN PATENT APPLICATION NO.**

EP 98 30 4989

This annex lists the patent family members relating to the patent documents cited in the above-mentioned European search report. The members are as contained in the European Patent Office EDP file on The European Patent Office is in no way liable for these particulars which are merely given for the purpose of information.

12-12-2002

Patent document cited in search report	Publication date	Patent family member(s)	Publication date
US 4831526 A	16-05-1989	NONE	

WO 9832289 A	23-07-1998	EP 1008262 A2	14-06-2000
		JP 2001509294 T	10-07-2001
		WO 9832289 A2	23-07-1998

EPC FORM P0469

For more details about this annex : see Official Journal of the European Patent Office, No. 12/82

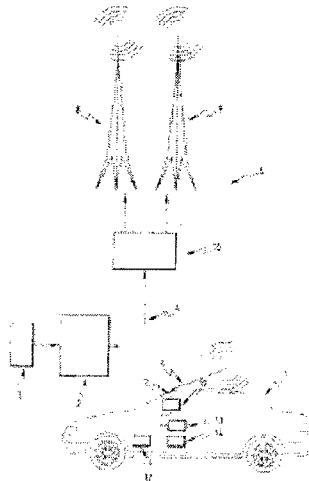

FIG. 1

Remote reprogramming system of at least a computer of an informatics system on board of an automobile

AB

(EP1128265)

The remote reprogramming system has a central server (2), where reprogramming information is stored, connected to a data communication network (4) which is in turn connected to a broadcast network (5,9). Each vehicle (1) is fitted with a receiver (6,7,11) of broadcast signals, and devices (12,13,14) to extract the reprogramming information and to use the information to reprogram its on-board computer(s).

IN LOUBEYRE YVES

PA PEUGEOT CITROEN AUTOMOBILES

PA0 Peugeot Citroen Automobiles SA; 62 Boulevard Victor Hugo; 92200 Neuilly sur Seine (FR)

Published As

Publ. number	Pub. date	Appl. number	Appl. date	Publ. Stage
FR2805365	20010824	2000FR-0002195	20000222	A1 - Application for patent of invention, (first publ.)
EP1128265	20010829	2001EP-0400351	20010209	A1 - Application published with search report
FR2805365	20021129			B1 - Patent of invention (second publication)

PR

2000FR-0002195 20000222

IC

B60R-016/02
G06F-009/445
G06F-011/30
G06F-015/177
H04L-029/06
H04L-029/08

ICO

T04L-029/08A7

ICAA

G06F-009/445 [2006-01 A - I R M EP];
H04L-029/06 [2006-01 A - I R M EP];
H04L-029/08 [2006-01 A - I R M EP]

ICCA

G06F-009/445 [2006 C - I R M EP];
H04L-029/06 [2006 C - I R M EP];
H04L-029/08 [2006 C - I R M EP]

EC

G06F-009/445N
H04L-029/06
H04L-029/08N11
H04L-029/08N33

CT

(EP1128265)

Search Report [Examiner]

US5826205(A)(Cat. X) [US5826205]

WO9831118(A1)(Cat. A) [WO9831118]

Applicant citations

US5442553(A) [US5442553]

DE19620885(A1) [DE19620885]

WO9632679(A1) [WO9632679]

DE19750372(A1) [DE19750372]

WO9726750(A1) [WO9726750]

(FR2805365)

Search Report [Examiner]

US5826205(A)(Cat. X) [US5826205]

WO9831118(A1)(Cat. A) [WO9831118]



Europäisches Patentamt
 European Patent Office
 Office européen des brevets



(11) EP 1 128 265 A1

(12) DEMANDE DE BREVET EUROPEEN

(43) Date de publication:
 29.08.2001 Bulletin 2001/35

(51) Int Cl.7: G06F 9/445

(21) Numéro de dépôt: 01400351.1

(22) Date de dépôt: 09.02.2001

(84) Etats contractants désignés:
 AT BE CH CY DE DK ES FI FR GB GR IE IT LI LU
 MC NL PT SE TR
 Etats d'extension désignés:
 AL LT LV MK RO SI

(72) Inventeur: **Loubeyre, Yves**
 92380 Garches (FR)

(74) Mandataire:
Habasque, Etienne Joel Jean-François et al
Cabinet Lavoix
 2, Place d'Estienne d'Orves
 75441 Paris Cédex 09 (FR)

(30) Priorité: 22.02.2000 FR 0002195

(71) Demandeur: **Peugeot Citroen Automobiles SA**
 92200 Neuilly sur Seine (FR)

(54) **Système de reprogrammation à distance d'au moins un calculateur d'un système informatique embarqué à bord d'un véhicule automobile**

(57) Ce système de reprogrammation à distance d'au moins un calculateur d'un système informatique embarqué à bord d'un véhicule automobile (1), est caractérisé en ce qu'il comporte des moyens (2) formant centre-serveur dans lequel sont stockées des informations de reprogrammation du calculateur, raccordés par un réseau (4) de communication d'informations à une infrastructure de télécommunication (5) adaptée pour entrer en contact et échanger des informations avec des moyens de télécommunication complémentaires (6) embarqués à bord du véhicule (1) et raccordés à un réseau de transmission d'informations (7) interne au véhicule auquel est raccordé le calculateur pour permettre la reprogrammation à distance de celui-ci.

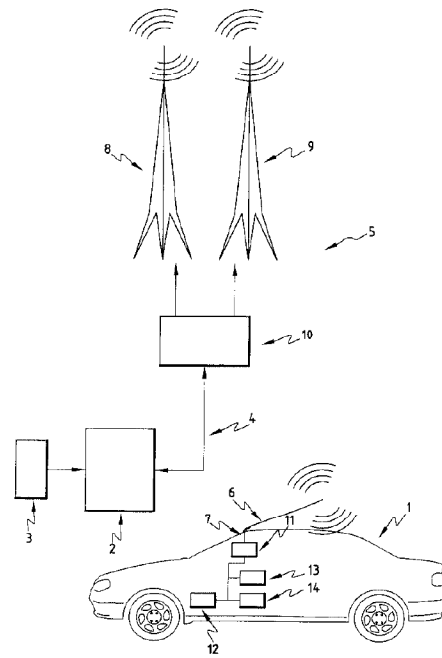

FIG.1

EP 1 128 265 A1

Description

[0001] La présente invention concerne un système de reprogrammation à distance d'au moins un calculateur d'un système informatique embarqué à bord d'un véhicule automobile.

[0002] On assiste depuis plusieurs années à une intégration croissante de calculateurs à bord des véhicules automobiles.

[0003] Il peut arriver que pour diverses raisons, il soit nécessaire de reprogrammer tout ou partie d'un ou de plusieurs de ces calculateurs.

[0004] Cette reprogrammation peut par exemple concerner la correction d'un programme, la correction d'une stratégie de contrôle et de commande d'un organe fonctionnel ou une modification de paramètres d'une fonction.

[0005] Cette reprogrammation nécessite alors la reprise du parc de véhicules par une campagne de rappel qui coûte souvent cher aux constructeurs aussi bien en terme d'image de marque qu'en terme financier.

[0006] Le but de l'invention est donc de résoudre ces problèmes.

[0007] A cet effet, l'invention a pour objet un système de reprogrammation à distance d'au moins un calculateur d'un système informatique embarqué à bord d'un véhicule automobile, caractérisé en ce qu'il comporte des moyens formant centre-serveur dans lequel sont stockées des informations de reprogrammation du calculateur, raccordés par un réseau de communication d'informations à une infrastructure de télécommunication adaptée pour entrer en contact et échanger des informations avec des moyens de télécommunication complémentaires embarqués à bord du véhicule et raccordés à un réseau de transmission d'informations interne au véhicule auquel est raccordé le calculateur pour permettre la reprogrammation à distance de celui-ci.

[0008] L'invention sera mieux comprise à la lecture de la description qui va suivre, donnée uniquement à titre d'exemple et faite en se référant aux dessins annexés, sur lesquels :

- la Fig.1 représente un schéma synoptique illustrant la structure d'un tel système de reprogrammation ; et
- la Fig.2 représente un organigramme illustrant le fonctionnement de celui-ci.

[0009] On a en effet représenté sur cette figure 1, un système de reprogrammation à distance d'au moins un calculateur d'un système informatique embarqué à bord d'un véhicule automobile.

[0010] Le véhicule automobile est désigné par la référence générale 1 sur cette figure.

[0011] Ce système comporte des moyens formant centre-serveur désignés par la référence générale 2, munis de moyens désignés par la référence générale 3

de stockage d'informations de reprogrammation de ce calculateur.

[0012] Ces moyens formant centre-serveur sont raccordés par un réseau de communication d'informations désigné par la référence générale 4, à une infrastructure de télécommunication désignée par la référence générale 5, adaptée pour entrer en contact et échanger des informations avec des moyens de télécommunication complémentaires désignés par la référence générale 6, embarqués à bord du véhicule 1 et raccordés à un réseau de transmission d'informations interne au véhicule, désigné par la référence générale 7, auquel est raccordé le calculateur pour permettre la reprogrammation à distance de celui-ci.

[0013] L'infrastructure de télécommunication peut comporter par exemple différents pylônes d'émission/réception d'informations tels que les pylônes désignés par les références 8 et 9 sur cette figure, répartis sur un territoire donné pour couvrir celui-ci, ces différents pylônes étant reliés à une base de télécommunication désignée par la référence générale 10.

[0014] De nombreux opérateurs mettent en oeuvre ce type d'infrastructures de télécommunication, celles-ci pouvant être utilisées pour entrer en contact et échanger des informations avec un véhicule.

[0015] Comme cela a été indiqué précédemment, le véhicule comporte des moyens de télécommunication complémentaires 6 comportant par exemple une antenne adaptée pour échanger des informations avec l'infrastructure de télécommunication, cette antenne étant reliée à un réseau de transmission d'informations interne au véhicule désigné par la référence générale 7.

[0016] Ce réseau est alors géré par exemple par un calculateur central 11 du véhicule et est raccordé à différents calculateurs embarqués à bord du véhicule, tels que par exemple les calculateurs désignés par les références 12, 13 et 14 sur cette figure.

[0017] Ces calculateurs peuvent par exemple comporter le calculateur de contrôle du fonctionnement du moteur du véhicule, le calculateur de contrôle du fonctionnement de la boîte de vitesses, le calculateur de contrôle du fonctionnement des suspensions, le calculateur de contrôle des moyens de freinage, etc...

[0018] Le système tel que décrit peut alors être utilisé pour assurer la reprogrammation d'au moins l'un de ces calculateurs.

[0019] A cet effet, lors du déclenchement d'une opération de reprogrammation d'un calculateur, le centre-serveur 2 déclenche l'émission d'une requête de mise en contact avec un véhicule déterminé, à destination de l'infrastructure de télécommunication qui recherche alors dans une base de données correspondantes, les coordonnées téléphoniques de ce véhicule afin de permettre l'établissement de la communication avec ce véhicule.

[0020] Cette étape est désignée par la référence générale 15 sur la figure 2 et permet d'établir une connexion entre le centre-serveur et le véhicule, en 16.

[0021] Au début de cette communication, le calculateur central 11 du véhicule émet à destination du centre-serveur, des informations d'identification du véhicule, telles que par exemple un numéro d'identification de celui-ci et des informations d'identification de sa composition et en particulier de sa composition électronique et informatique.

[0022] Cette étape est illustrée en 17 sur la figure 2.

[0023] En 18, le centre-serveur émet à destination du véhicule, des informations de déverrouillage du système informatique embarqué à bord du véhicule et en particulier du calculateur central 11 de celui-ci.

[0024] Ces informations de déverrouillage sont alors comparées par exemple à des informations prédéterminées stockées dans le calculateur central 11 pour valider ou non le déverrouillage du système.

[0025] Si les informations de déverrouillage sont incorrectes, le système reste verrouillé et la procédure de reprogrammation est rejetée, comme cela est illustré en 19 sur cette figure 2.

[0026] Par contre, si le déverrouillage est accepté, le calculateur central 11 vérifie si des conditions de sécurité de fonctionnement du véhicule sont remplies comme cela est illustré en 20 sur la figure 2.

[0027] Ces conditions peuvent par exemple concerner le fait que le véhicule est à l'arrêt ou non, etc...

[0028] Si ces conditions de sécurité sont remplies, le calculateur central 11 assure le blocage des autres calculateurs du véhicule comme cela est illustré en 21 pour inhiber toute intervention possible d'un utilisateur du véhicule afin de ne pas perturber la reprogrammation de ces calculateurs.

[0029] Cette étape peut par exemple être associée à la génération d'un signal d'avertissement de l'utilisateur du véhicule lui indiquant qu'une opération de reprogrammation est en cours afin de bien lui faire comprendre ce qui se passe.

[0030] Une fois le système informatique embarqué à bord du véhicule bloqué, le calculateur central 11 assure la reprogrammation du ou des calculateurs correspondants lors de l'étape 22 à partir des informations reçues du centre-serveur par l'intermédiaire de l'infrastructure de télécommunication.

[0031] Le calculateur central 11 détermine alors le ou les calculateurs à reprogrammer et assure la reprogrammation de ceux-ci à travers le réseau de transmission d'informations interne au véhicule.

[0032] Une fois cette reprogrammation effectuée, le calculateur central 11 déclenche en 23 une vérification de la procédure de reprogrammation sur chaque calculateur modifié afin que ces derniers vérifient leur bon chargement.

[0033] Enfin, lors de l'étape 24, le calculateur central 11 mémorise un historique des opérations de reprogrammation et émet à destination du centre-serveur un compte rendu de l'opération de reprogrammation afin qu'une trace de cette opération soit conservée au niveau de ce centre-serveur.

[0034] Cette émission est illustrée en 25 sur cette figure 2.

[0035] La procédure est alors terminée en 26.

[0036] Un tel système peut mettre en oeuvre des messages de type Internet émanant par exemple d'un centre-serveur d'une station d'un garage central d'un constructeur correspondant qui émet alors un code de recherche pour identifier un véhicule concerné.

[0037] Ce code qui correspond par exemple au numéro d'identification d'un véhicule permet d'identifier la composition électronique de celui-ci, le nombre de calculateurs, le type de systèmes de contrôle présents, l'état des versions, etc..

[0038] Si le calculateur central du véhicule reconnaît ce numéro, il accepte la communication et permet ainsi la procédure de reprogrammation.

[0039] Deux cas peuvent alors être prévus, selon que le véhicule est activé ou non.

[0040] Si le véhicule n'est pas activé, il n'y a aucune modification possible des calculateurs du véhicule, car le système informatique est considéré comme non opérationnel.

[0041] Ceci permet d'éviter de remettre à jour des véhicules non utilisés régulièrement.

[0042] Par contre, si le véhicule est activé, c'est-à-dire que l'ensemble des calculateurs est sous tension, que ce véhicule soit roulant ou à l'arrêt, le calculateur central de celui-ci peut admettre la requête de modification d'un ou des calculateurs.

[0043] A cet effet, le calculateur central doit attendre que le conducteur du véhicule arrête celui-ci et coupe le contact.

[0044] Le calculateur central peut alors maintenir l'alimentation du système informatique afin de pouvoir effectuer toutes les modifications nécessaires tout en gardant un maximum de sécurité.

[0045] C'est ainsi que ces modifications sont effectuées lorsque le conducteur n'utilise pas le véhicule.

[0046] Comme cela a été indiqué précédemment, l'ensemble des calculateurs du véhicule est relié par l'intermédiaire d'un réseau interne au véhicule, ce qui permet d'assurer la transmission des informations.

[0047] L'opération de reprogrammation n'est bien entendue autorisée qu'à partir du moment où le système informatique a été déverrouillé par l'utilisation d'un mot de passe correct.

[0048] Dans le cas où l'ensemble des modifications n'est pas terminé alors que le conducteur rentre à nouveau dans son véhicule, il peut être nécessaire de faire apparaître au niveau du tableau de bord, un avertissement indiquant que le véhicule est momentanément indisponible et en inhibant toute action par exemple sur la clé de contact du véhicule.

[0049] Le conducteur comprend alors qu'une mise à jour automatique des calculateurs de son véhicule est en train d'être effectuée.

[0050] Une fois les modifications effectuées, le calculateur central lance un contrôle automatique de ces cal-

culateurs afin de s'assurer du bon fonctionnement de cette opération de reprogrammation.

[0051] Le calculateur central stocke également, par exemple par écriture en Flash EPROM, l'ensemble des opérations de reprogrammation avec leur date, le type de modification, etc..., puis coupe automatiquement l'alimentation des calculateurs.

[0052] Lorsque le conducteur du véhicule reprend son véhicule, il voit par exemple par une indication au tableau de bord qu'une mise à jour a été effectuée.

[0053] Il peut alors soit passer chez un garagiste pour connaître l'ensemble des problèmes résolus, soit interroger directement le centre-serveur et voir afficher sur un site Internet par exemple, l'ensemble des modifications.

[0054] Le réseau du constructeur conserve également en mémoire toutes les opérations effectuées sur le véhicule.

[0055] L'utilisation de numéros d'identification des véhicules permet également à un constructeur de connaître l'ensemble du parc de véhicules concernés.

[0056] En cas de panne ou d'accident, un réparateur quelconque peut également interroger le véhicule pour connaître son identification et donc sa composition et adapter les interventions de dépannage en fonction de celui-ci.

[0057] Le calculateur central peut d'ailleurs détecter une anomalie ou un dysfonctionnement du véhicule et émettre à destination du centre-serveur du constructeur, un message correspondant afin que celui-ci ait un historique des pannes et puisse intervenir plus efficacement dans la recherche d'un problème ou l'explication d'un dysfonctionnement.

[0058] Bien entendu, les opérations de reprogrammation des calculateurs peuvent se faire soit systématiquement, soit à la requête d'un client, par exemple dans le cadre d'un contrat de maintenance préventive.

[0059] Un tel système permet également une communication entre par exemple un garagiste et un véhicule pour permettre un diagnostic de l'ensemble du fonctionnement du système informatique du véhicule sans intervention humaine sur le véhicule.

[0060] Le calculateur central transmet alors les requêtes de diagnostic à l'ensemble des calculateurs du véhicule et émet des informations de diagnostic pour analyse par le garagiste.

[0061] Toutes les opérations classiques de diagnostic faites aujourd'hui par les systèmes de test en garage, peuvent alors être faites sur ce même principe, ce qui permet d'éviter non seulement le développement de nouveaux moyens de diagnostic, mais également des interventions humaines sur les véhicules.

[0062] Une telle opération peut par exemple être réalisée par un spécialiste de tel ou tel calculateur qui peut alors l'interroger à distance, afin d'aider à la recherche d'une panne.

[0063] On notera également que les moyens formant centre-serveur dans lesquels sont stockées des infor-

mations de reprogrammation peuvent être raccordés à l'infrastructure de télécommunication par un réseau de communication à liaison filaire, à satellite, etc...

[0064] Bien entendu, d'autres modes de réalisation encore d'un tel système peuvent être envisagés.

Revendications

1. Système de reprogrammation à distance d'au moins un calculateur d'un système informatique embarqué à bord d'un véhicule automobile (1), caractérisé en ce qu'il comporte des moyens (2) formant centre-serveur dans lequel sont stockées des informations de reprogrammation du calculateur, raccordés par un réseau (4) de communication d'informations à une infrastructure de télécommunication (5) adaptée pour entrer en contact et échanger des informations avec des moyens de télécommunication complémentaires (6) embarqués à bord du véhicule (1) et raccordés à un réseau de transmission d'informations (7) interne au véhicule auquel est raccordé le calculateur pour permettre la reprogrammation à distance de celui-ci.
2. Système selon la revendication 1, caractérisé en ce que le système informatique du véhicule comporte un calculateur central (11) de gestion du fonctionnement de celui-ci.
3. Système selon la revendication 1 ou 2, caractérisé en ce que lors du lancement d'une opération de reprogrammation par le centre-serveur, l'infrastructure de télécommunication (5) est adaptée pour rechercher les coordonnées téléphoniques du véhicule dans une base de données afin d'entrer en communication avec celui-ci (en 15 et 16) de manière à permettre un échange d'informations d'identification entre le centre-serveur et le véhicule (en 17) pour déverrouiller ou non (en 18) le système informatique et en ce qu'en cas de déverrouillage du système, le calculateur central (11) est adapté pour vérifier (en 20) des conditions de sécurité liées au fonctionnement du véhicule, bloquer (en 21) les calculateurs du système, assurer (en 22) la reprogrammation du ou des calculateurs correspondants, déclencher (en 23) une opération de vérification de la procédure de reprogrammation et assurer (en 24), une mémorisation de cette opération et l'émission à destination du centre-serveur d'un compte rendu de cette opération de reprogrammation avant d'autoriser à nouveau l'utilisation du véhicule.
4. Système selon la revendication 3, caractérisé en ce que le calculateur central (11) et le centre-serveur (2) comprennent des moyens de diagnostic du fonctionnement du système informatique du véhicule.

5. Système selon l'une quelconque des revendications précédentes, caractérisé en ce que les moyens (2) formant centre-serveur sont raccordés à l'infrastructure de télécommunication (5) par un réseau de communication filaire. 5

6. Système selon l'une quelconque des revendications précédentes, caractérisé en ce que les moyens (2) formant centre-serveur sont raccordés à l'infrastructure de télécommunication (5) par un réseau de communication à satellite. 10

15

20

25

30

35

40

45

50

55

5

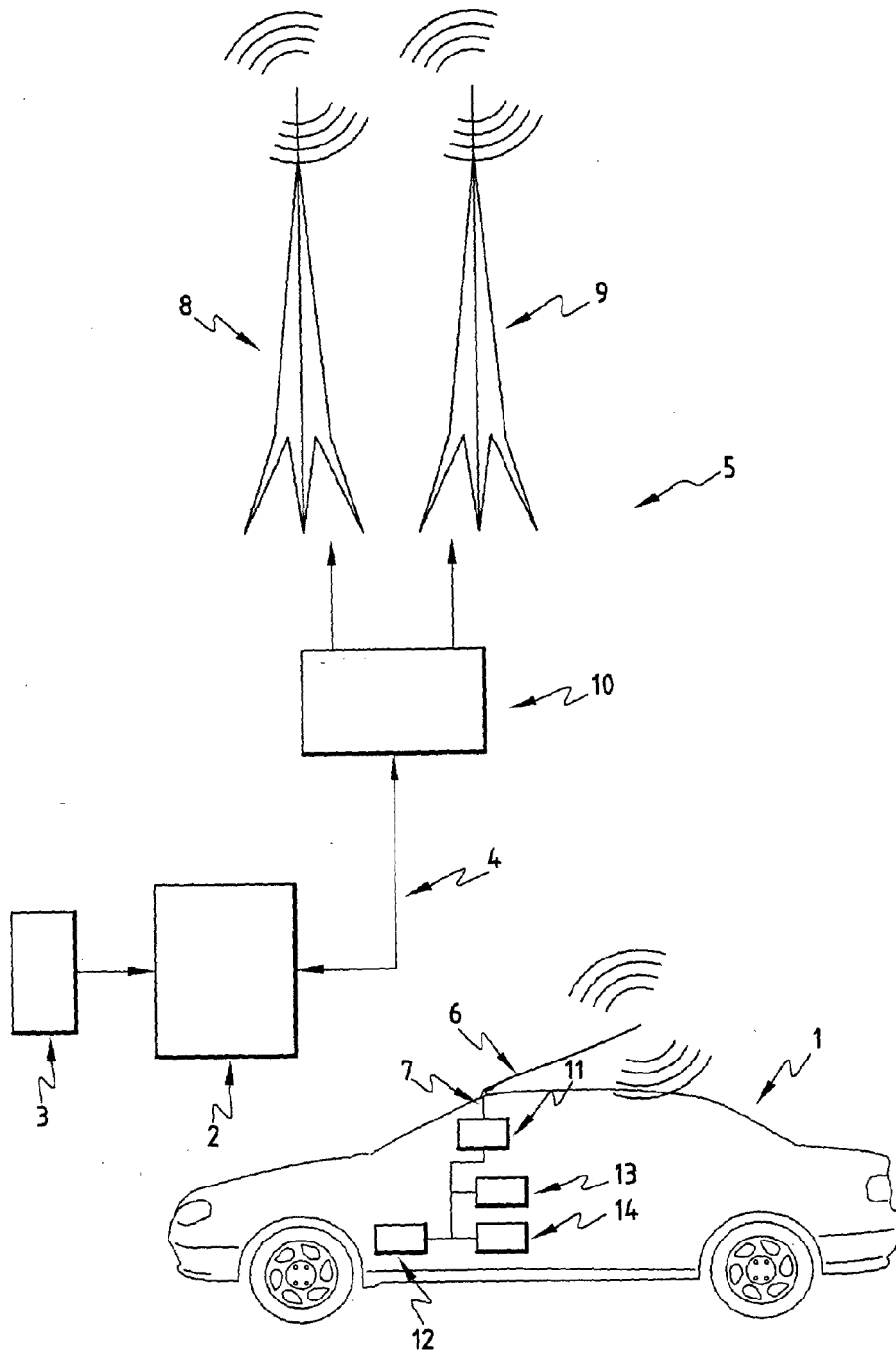

FIG. 1

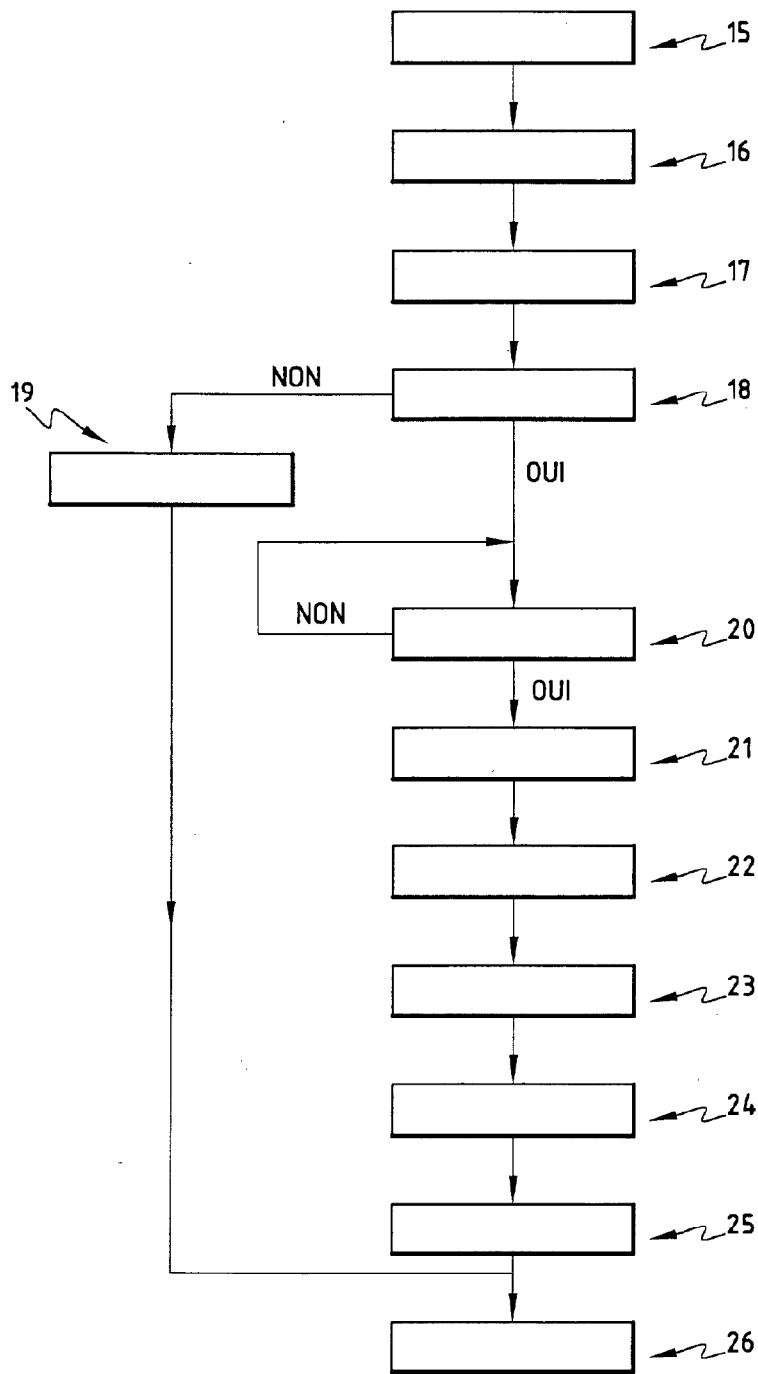

FIG.2



DOCUMENTS CONSIDERES COMME PERTINENTS			
Catégorie	Citation du document avec indication, en cas de besoin, des parties pertinentes	Revendication concernée	CLASSEMENT DE LA DEMANDE (Int.Cl.7)
X	US 5 826 205 A (SCHULZ HANS-JOERG ET AL) 20 octobre 1998 (1998-10-20)	1,2,5,6	G06F9/445
A	* abrégé; figure 1 * * colonne 1, ligne 52 - colonne 4, ligne 7 * ---	3,4	
A	WO 98 31118 A (MOTOROLA INC) 16 juillet 1998 (1998-07-16) * page 1, ligne 1 - page 3, ligne 12; revendications 1,2,6; figure 1 * -----	1,3,4	
Le présent rapport a été établi pour toutes les revendications			DOMAINES TECHNIQUES RECHERCHES (Int.Cl.7)
			G06F H04L B60R
Lieu de la recherche		Date d'achèvement de la recherche	Examineur
LA HAYE		11 juin 2001	Kingma, Y
CATEGORIE DES DOCUMENTS CITES			
X : particulièrement pertinent à lui seul Y : particulièrement pertinent en combinaison avec un autre document de la même catégorie A : arrière-plan technologique O : divulgation non-écrite P : document intercalaire		T : théorie ou principe à la base de l'invention E : document de brevet antérieur, mais publié à la date de dépôt ou après cette date D : cité dans la demande L : cité pour d'autres raisons & : membre de la même famille, document correspondant	

EPC FORM 503 (03/98) (P/54/02E)

**ANNEXE AU RAPPORT DE RECHERCHE EUROPEENNE
RELATIF A LA DEMANDE DE BREVET EUROPEEN NO.**

EP 01 40 0351

La présente annexe indique les membres de la famille de brevets relatifs aux documents brevets cités dans le rapport de recherche européenne visé ci-dessus.
Lesdits membres sont contenus au fichier informatique de l'Office européen des brevets à la date du
Les renseignements fournis sont donnés à titre indicatif et n'engagent pas la responsabilité de l'Office européen des brevets.

11-06-2001

Document brevet cité au rapport de recherche	Date de publication	Membre(s) de la famille de brevet(s)	Date de publication
US 5826205 A	20-10-1998	DE 4425388 A	25-01-1996
		JP 8083176 A	26-03-1996
WO 9831118 A	16-07-1998	US 6114970 A	05-09-2000
		EP 0888673 A	07-01-1999
		JP 2000508499 T	04-07-2000

EPO FORM P0160

Pour tout renseignement concernant cette annexe : voir Journal Officiel de l'Office européen des brevets, No.12/B2

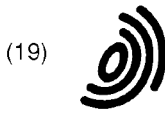

(19)

Europäisches Patentamt
European Patent Office
Office européen des brevets



(11)

EP 1 160 707 A1

(12)

EUROPEAN PATENT APPLICATION

(43) Date of publication:
05.12.2001 Bulletin 2001/49

(51) Int Cl.7: **G06F 17/60**

(21) Application number: **01303501.9**

(22) Date of filing: **17.04.2001**

(84) Designated Contracting States:
**AT BE CH CY DE DK ES FI FR GB GR IE IT LI LU
MC NL PT SE TR**
Designated Extension States:
AL LT LV MK RO SI

- **Craig, Alexander**
Moreland Hills, Ohio 44022 (US)
- **Heinen, John P.**
Tampa, Florida 33647 (US)
- **Olexa, Byron J.**
Mentor-on-the-Lake, Ohio 44060 (US)
- **McElroy, Marc C.**
South Euclid, Ohio 44106 (US)
- **Lee, Robert S.**
Hudson, Ohio 44236 (US)

(30) Priority: **15.05.2000 US 571650**

(71) Applicant: **Progressive DirecTrac Service Corp.**
Mayfield Village, Ohio 44143 (US)

(74) Representative: **Brookes Batchellor**
102-108 Clerkenwell Road
London EC1M 5SA (GB)

(72) Inventors:

- **Henderson, Maria**
Tampa, Florida 33611 (US)
- **McMillan, Robert J.**
Colorado Springs, Colorado 80906 (US)

(54) **Monitoring system for determining and communicating a cost of insurance**

(57) A method and system for communicating insurance related services between an insured and an insurer through an Internet communication scheme includes a processing system for processing acquired event and sensed data to compute the cost of insurance for the same period as the data is acquired. An enhanced In-

ternet communication scheme provides an insured access to the acquired data and its processing through enhanced presentation systems (e.g., maps with usage, service or special event processing or even automobile service diagnostics.) In addition, communication packages can provide estimates based upon user-supplied information identifying projected usages.

EP 1 160 707 A1

Description

Field of the Invention

5 [0001] The present invention relates to data acquisition, processing and communicating systems, and particularly to a system for acquiring and handling relevant data for an insured unit of risk for purposes of providing a more accurate determination of cost of insurance for the unit of risk and for communicating or quoting the so determined cost to an owner of the unit of risk. Although the invention has its principal applicability to motor vehicles such as automobiles, the invention is equally applicable to other units of risk such as, without limitation, motorcycles, motor homes, trucks, tractors, vans, buses, boats and other water craft and aircraft. The invention especially relates to a system for monitoring and communicating units of risk operational characteristics and operator actions for implementing the operational characteristics, to obtain increased amounts of data relating to the safety or risk of use for a subject unit, for purposes of providing a more accurate determination of the cost of insurance corresponding to a real time usage of the risk unit, and for making such data and computed costs accessible to a customer or insured or others on hardcopy, over the Internet or by other electronic means for convenient communication. The invention relates to electronic commerce, particularly where insurance and related information is marketed, sold or communicated via the Internet or other interactive network.

Background of the Invention

20 [0002] Conventional methods for determining costs of motor vehicle insurance involve gathering relevant historical data from a personal interview with the applicant for the insurance and by referencing the applicant's public motor vehicle driving record that is maintained by a governmental agency, such as a Bureau of Motor Vehicles. Such data results in a classification of the applicant to a broad actuarial class for which insurance rates are assigned based upon the empirical experience of the insurer. Many factors are relevant to such classification in a particular actuarial class, such as age, sex, marital status, location of residence and driving record.

25 [0003] The current system of insurance creates groupings of vehicles and drivers (actuarial classes) based on the following types of classifications.

30	Vehicle	Age; manufacturer, model; and value.
35	Driver	Age; sex; marital status; driving record (based on government reports), violations (citations); at fault accidents; and place of residence.
40	Coverage	Types of losses covered, liability, 45 uninsured motorist, comprehensive, and collision; 50 liability limits; and deductibles.

[0004] The classifications, such as age, are further broken into actuarial classes, such as 21 to 24, to develop a unique vehicle insurance cost based on the specific combination of actuarial classes for a particular risk. For example, the following information would produce a unique vehicle insurance cost.

55	Vehicle	Age	1997 (three years old)
		manufacturer, model	Ford, Explorer XLT

EP 1 160 707 A1

(continued)

5	Driver	value	\$ 18,000.
		Age	38 years old
		sex	male
		marital status	single
		driving record (based on government reports)	
10		violations	1 point (speeding)
		at fault accidents	3 points (one at fault accident)
		place of residence	33619 (zip code)
	Coverage	Types of losses covered	
15		liability	yes
		uninsured motorist	no
		comprehensive	yes
		collision	yes
20		liability limits	\$100,000./\$300,000./\$50,000.
		deductibles	\$500./\$500.

[0005] A change to any of this information would result in a different premium being charged, if the change resulted in a different actuarial class for that variable. For instance, a change in the drivers' age from 38 to 39 may not result in a different actuarial class, because 38 and 39 year old people may be in the same actuarial class. However, a change in driver age from 38 to 45 may result in a different premium because of the change in actuarial class.

[0006] Current insurance rating systems also provide discounts and surcharges for some types of use of the vehicle, equipment on the vehicle and type of driver. Common surcharges and discounts include:

30	Surcharges	Business use.
	Discounts	Safety equipment on the vehicle
35		airbags, and
		antilock brakes;
		theft control devices
		passive systems (e.g. "The Club"), and
40		alarm system; and
		driver type
		good student, and
		safe driver (accident free).
45		group
		senior drivers
		fleet drivers

[0007] A principal problem with such conventional insurance determination systems is that much of the data gathered from the applicant in the interview is not verifiable, and even existing public records contain only minimal information, much of which has little relevance towards an assessment of the likelihood of a claim subsequently occurring. In other words, current rating systems are primarily based on past realized losses. None of the data obtained through conventional systems necessarily reliably predicts the manner or safety of future operation of the vehicle. Accordingly, the limited amount of accumulated relevant data and its minimal evidential value towards computation of a fair cost of insurance has generated a long-felt need for an improved system for more reliably and accurately accumulating data having a highly relevant evidential value towards predicting the actual manner of a vehicle's future operation.

[0008] Many types of vehicle operating data recording systems have heretofore been suggested for purposes of maintaining an accurate record of certain elements of vehicle operation. Some are suggested for identifying the cause for an accident, others are for more accurately assessing the efficiency of operation. Such systems disclose a variety

of conventional techniques for recording vehicle operation data elements in a variety of data recording systems. In addition, it has also been suggested to provide a radio communication link for such information via systems such as a cellular telephone to provide immediate communication of certain types of data elements or to allow a more immediate response in cases such as theft, accident, break-down or emergency. It has even been suggested to detect and record seatbelt usage to assist in determination of the vehicle insurance costs (U.S. Patent No. 4,667,336).

[0009] The various forms and types of vehicle operating data acquisition and recordal systems that have heretofore been suggested and employed have met with varying degrees of success for their express limited purposes. All possess substantial defects such that they have only limited economical and practical value for a system intended to provide an enhanced acquisition, recordal and communication system of data which would be both comprehensive and reliable in predicting an accurate and adequate cost of insurance for the vehicle. Since the type of operating information acquired and recorded in prior art systems was generally never intended to be used for determining the cost of vehicle insurance, the data elements that were monitored and recorded therein were not directly related to predetermined safety standards or the determining of an actuarial class for the vehicle operator. For example, recording data characteristics relevant to the vehicle's operating efficiency may be completely unrelated to the safety of operation of the vehicle. Further, there is the problem of recording and subsequently compiling the relevant data for an accurate determination of an actuarial profile and an appropriate insurance cost therefor.

[0010] Current motor vehicle control and operating systems comprise electronic systems readily adaptable for modification to obtain the desired types of information relevant to determination of the cost of insurance. Vehicle tracking systems have been suggested which use communication links with satellite navigation systems for providing information describing a vehicle's location based upon navigation signals. When such positioning information is combined with roadmaps in an expert system, vehicle location is ascertainable. Mere vehicle location, though, will not provide data particularly relevant to safety of operation unless the data is combined with other relevant data in an expert system which is capable of assessing whether the roads being driven are high-risk or low-risk with regard to vehicle safety.

[0011] On-line Web sites for marketing and selling goods have become common place. Many insurers offer communication services to customers via Web sites relevant to an insured profile and account status. Commonly assigned pending application U.S. Serial No. 09/135,034, filed August 17, 1998, now U.S. Patent No. 6,064,970 discloses one such system. Customer comfort with such Web site communication has generated the need for systems which can provide even more useful information to customers relative to a customer's contract with the insurer. Such enhanced communications can be particularly useful to an insured when the subject of the communications relates to real time cost determination, or when the subject relates to prospective reoccurring insurable events wherein the system can relate in the existing insured's profile with some insurer provided estimates of a future event for deciding an estimated cost of insuring the event.

[0012] The present invention contemplates a new and improved monitoring, recording and communicating system for an insured unit of risk, which primarily overcomes the problem of determining cost of vehicle insurance based upon data which does not take into consideration how a specific unit of risk is operated. The subject invention will base insurance charges with regard to current material data representative of actual operating characteristics to provide a classification rating of an operator or the unit in an actuarial class which has a vastly reduced rating error over conventional insurance cost systems. Additionally, the present invention allows for frequent (monthly) adjustment to the cost of coverage because of the changes in operating behavior patterns. This can result in insurance charges that are readily controllable by individual operators. The system is adaptable to current electronic operating systems, tracking systems and communicating systems for the improved extraction of selected insurance related data. In addition, the system provides for enhanced and improved communication of the relevant acquired data, cost estimates of insuring events and customer insured profiles through an Internet/Web site.

Brief Summary of the Invention

[0013] In accordance with the present invention, there is disclosed a method of determining a cost of automobile insurance based upon monitoring, recording and communicating data representative of operator and vehicle driving characteristics, whereby the cost is adjustable by relating the driving characteristics to predetermined safety standards. The method is comprised of steps of monitoring a plurality of raw data elements representative of an operating state of a vehicle or an action of the operator. Selected ones of the plurality of raw data elements are recorded when they are determined to have an identified relationship to the safety standards. The recorded elements are consolidated for processing against an insured profile and for identifying a surcharge or discount to be applied to a base cost of automobile insurance. The total cost of insurance obtained from combining the base cost and surcharges or discounts is produced as a final cost to the operator.

[0014] In accordance with another aspect of the present invention, the recording comprises identifying a trigger event associated with the raw data elements which has an identified relationship to the safety standards so that trigger information representative of the event is recorded.

[0015] In accordance with a more limited aspect of the present invention, the method comprises a step of immediately communicating to a central control station via an uplink, information representative of the trigger event and recording response information generated by the control station.

5 [0016] In accordance with yet another aspect of the present invention, the method comprises steps of generating calculated data elements and derived data elements from the raw data elements, and accumulating the calculated and derived data elements in a recording device.

[0017] In accordance with the present invention, there is provided a method and system for Internet on-line communicating, between an insurer and an insured, of detected operating characteristics of a unit of risk, (e.g., a vehicle) for a selected period, and the cost of insuring the unit for the selected period, as decided by the insurer in consideration of the detected operating characteristics. A Web site system is provided for selectively communicating the operating characteristics and the cost between the insurer and the insured. A monitoring system monitors the operating characteristics. A storage system stores the operating characteristics and is accessible to the Web site system. A processing system decides the cost of insuring the unit for a period based upon the operating characteristics monitored during that period. The processing system is also accessible to the Web site system.

15 [0018] One benefit obtained by use of the present invention is a system that will provide precise and timely information about the current operation of an insured motor vehicle that will enable an accurate determination of operating characteristics, including such features as miles driven, time of use and speed of the vehicle. This information can be used to establish actual usage based insurance charges, eliminating rating errors that are prevalent in traditional systems and will result in vehicle insurance charges that can be directly controlled by individual operators.

20 [0019] It is another benefit of the subject invention that conventional motor vehicle electronics are easily supplemented by system components comprising a data recording process, a navigation system and a communications device to extract selected insurance relevant data from the motor vehicle.

[0020] It is another object of the present invention to generate actuarial classes and operator profiles relative thereto based upon actual driving characteristics of the vehicle and driver, as represented by the monitored and recorded data elements for providing a more knowledgeable, enhanced insurance rating precision.

25 [0021] It is another aspect of the present invention that an on-line Web site is provided for communicating data, services, and estimates to customers via an Internet Web Site, including estimated costs for expected operating usage for a particular unit of risk. Accordingly, the real time cost determination and communication through the Web site provides the type of enhanced communications between a customer and an insurer that can be particularly useful in limiting costs, and enhancing safety.

30 [0022] It is another benefit of the invention that a user of a unit of risk may be authenticated as a proper user of the unit, and a more accurate rating for the authenticated user may be implemented for the computation of insurance costs.

[0023] The subject new insurance rating system retrospectively adjusts and prospectively sets premiums based on data derived from motor vehicle operational characteristics and driver behavior through the generation of new actuarial classes determined from such characteristics and behavior, which classes heretofore have been unknown in the insurance industry. The invention comprises an integrated system to extract via multiple sensors, screen, aggregate and apply for insurance rating purposes, data generated by the actual operation of the specific vehicle and the insured user/driver.

40 **Brief Description of the Drawings**

[0024] The invention may take physical form in certain parts and steps and arrangements of parts and steps, the preferred embodiments of which will be described in detail in this specification and illustrated in the accompanying drawings which form a part hereof and wherein:

45 FIGURE 1 is a block diagram/flowchart generally describing data capture methods within a unit of risk for insurance in claims processing;

FIGURE 2 is a block diagram generally illustrated in the communication network design the unit of risk including a response center of the insurer and a data handling center;

50 FIGURE 3 is a suggestive perspective drawing of a vehicle including certain data elements monitoring, recording and communication devices;

FIGURE 4 is a block diagram of a vehicle onboard computer and recording system implementing the subject invention for selective communication with a central operations control center and a global positioning navigation system;

55 FIGURE 5 is a block diagram illustrating use of acquired data including communication through Internet access; and,

FIGURE 6 is a block diagram/flowchart illustrating an underwriting and rating method for determining a cost of insurance in conjunction with the system of FIG. 4.

Detailed Description of the Preferred Embodiments

[0025] The following terms and acronyms are used throughout the detailed description:

5 [0026] Internet. A collection of interconnected (public and/or private) networks that are linked together by a set of standard protocols (such as TCP/IP and HTTP) to form a global, distributed network. While this term is intended to refer to what is now commonly known as the Internet, it is also intended to encompass variations which may be made in the future, including changes and additions to existing standard protocols.

10 [0027] World Wide Web ("Web"). Used herein to refer generally to both (i) a distributed collection of interlined, user-viewable hypertext documents (commonly referred to as Web documents or Web pages) that are accessible via the Internet, and (ii) the client and server software components which provide user access to such documents using standardized Internet protocols. Currently, the primary standard protocol for allowing applications to locate and acquire Web documents is HTTP, and the Web pages are encoded using HTML. However, the terms "Web" and "World Wide Web" are intended to encompass future markup languages and transport protocols which may be used in place of (or in addition to) HTML and HTTP.

15 [0028] Web Site. A computer system that serves informational content over a network using the standard protocols of the World Wide Web. Typically, a Web site corresponds to a particular Internet domain name, such as "progressive.com," and includes the content associated with a particular organization. As used herein, the term is generally intended to encompass both (i) the hardware/software server components that serve the informational content over the network, and (ii) the "back end" hardware/software components including any non-standard or specialized components, that interact with the server components to perform services for Web site users.

20 [0029] Referring now to the drawings, wherein the showings are for purposes of illustrating the preferred embodiments of the invention only and not for purposes of limiting same, the FIGURES show an apparatus and method for monitoring, recording and communicating insurance related data for determination of an accurate cost of insurance based upon evidence relevant to the actual operation and in particular the relative safety of that operation. Generally, a unit of risk, e.g., vehicle, user is charged for insurance based upon statistical averages related to the safety of operation based upon the insurer's experience with other users who drive similar vehicles in a similar geographic area. The invention allows for the measure of the actual data while the motor vehicle is being driven. Such data measurement will allow the vehicle user to directly control his/her insurance costs by operating the vehicle in a manner which he/she will know will evidence superior safety of operation and a minimal risk of generation of an insurance claim. Examples of data which can be monitored and recorded include:

- 30
1. Actual miles driven;
 2. Types of roads driven on (high risk vs. low risk); and,
 3. Safe operation of the vehicle by the vehicle user through:
 - 35 A. speeds driven,
 - B. safety equipment used, such as seat belt and turn signals,
 - C. time of day driven (high congestion vs. low congestion),
 - 40 D. rate of acceleration,
 - E. rate of braking,
 - F. observation of traffic signs.
 4. Driver identification

45 [0030] With reference to FIGURE 3, an exemplary motor vehicle is shown in which the necessary apparatus for implementing the subject invention is included. An on-board computer 300 monitors and records various sensors and operator actions to acquire the desired data for determining a fair cost of insurance. Although not shown therein, a plurality of operating sensors are associated with the motor vehicle to monitor a wide variety of raw data elements. Such data elements are communicated to the computer through a connections cable which is operatively connected to the vehicle data bus 304 through an SAE-J1978 connector, or OBD-II connector or other vehicle sensors 306. A driver input device 308 is also operatively connected to the computer 300 through connector 307 and cable 302. The computer is powered through the car battery 310, a conventional generator system, a battery or a solar based system (not shown). Tracking of the vehicle for location identification can be implemented by the computer 300 through navigation signals obtained from a GPS (global positioning system) antenna, a differential GPS or other locating system 50 312. The communications link to a central control station is accomplished through the cellular telephone, radio, satellite or other wireless communication system 314.

55 [0031] FIGURE 4 provides the block diagram of the in-vehicle computer system. The computer 300 is comprised of several principal components, an on-board data storage device, an input/output subsystem for communicating to a

EP 1 160 707 A1

variety of external devices, a central processing unit and memory device and a real time operating kernel for controlling the various processing steps of the computer 300. It is known that all of these functions can be included in a single dedicated microprocessor circuit 300. The computer 300 essentially communicates with a number of on-board vehicle devices for acquisition of information representative of various actual vehicle operating characteristics. A driver input console 410 allows the driver to input data representative of a need for assistance or for satisfaction of various threshold factors which need to be satisfied before the vehicle can be operated.

[0032] For example, a driver authentication system is intended, such as where several individual drivers (same family, etc.) may properly use the vehicle but each may have different ratings for insurance computations.

[0033] The physical operation of the vehicle is monitored through various sensors 412 in operative connection with the vehicle data bus, while additional sensors 414 not normally connected to the data bus can be in direct communication with the computer 300 as will hereinafter be more fully explained.

[0034] The vehicle is linked to an operation control center 416 by a communications link 418, preferably comprising a conventional cellular telephone interconnection, but also comprising satellite transmission, magnetic or optical media, radio frequency or other known communication technology. A navigation sub-system 420 receives radio navigation signals from a positioning device 422 which may include, but is not limited to GPS, radio frequency tags, or other known locating technology.

[0035] The type of elements monitored and recorded by the subject invention comprise raw data elements, calculated data elements and derived data elements. These can be broken down as follows:

Raw Data Elements:

[0036]

Power train sensors

RPM,
transmission setting (Park, Drive, Gear, Neutral),
throttle position,
engine coolant temperature,
intake air temperature,
barometric pressure;

Electrical sensors

brake light on,
turn signal indicator,
headlamps on,
hazard lights on,
back-up lights on,
parking lights on,
wipers on,
doors locked,
key in ignition,
key in door lock,
horn applied;

Body sensors

airbag deployment,
ABS application,
level of fuel in tank,
brakes applied,
radio station tuned in,
seat belt on,
door open,
tail gate open,
odometer reading,
cruise control engaged,

EP 1 160 707 A1

anti-theft disable,
occupant in seat,
occupant weight;

5 Other sensors

vehicle speed,
vehicle location,
date,
10 time,
vehicle direction,
IVHS data sources
pitch and roll,
relative distance to other objects.

15 **Calculated Data Elements:**

[0037]

20 rapid deceleration;
rapid acceleration;
vehicle in skid;
wheels in spin;
closing speed of vehicle in front;
25 closing speed of vehicle in rear;
closing speed of vehicle to side (right or left);
space to side of vehicle occupied;
space to rear of vehicle occupied;
space to front of vehicle occupied;
30 lateral acceleration;
sudden rotation of vehicle;
sudden loss of tire pressure;
driver identification (through voice recognition or code or fingerprint recognition);
distance traveled; and
35 environmental hazard conditions (e.g. icing, etc.).

Derived Data Elements:

[0038]

40 vehicle speed in excess of speed limit;
observation of traffic signals and signs;
road conditions;
traffic conditions; and
45 vehicle position.

[0039] This list includes many, but not all, potential data elements.

[0040] With particular reference to FIG. 1, a flowchart generally illustrating the data capture process of the subject invention within the vehicle for insurance and claims processing, is illustrated. Such a process can be implemented with conventional computer programming in the real time operating kernel of the computer **300**. Although it is within the scope of the invention that each consumer could employ a unique logic associated with that consumer's unit of risk, based on the underwriting and rating determination (FIG. 6), as will be more fully explained later, FIG. 1 illustrates how the data capture within a particular consumer logic is accomplished. After the system is started **100**, data capture is initiated by a trigger event **102** which can include, but is not limited to:

55 Ignition On/Off
Airbag Deployment
Acceleration Threshold

EP 1 160 707 A1

- Velocity Threshold
- Elapsed Time
- Battery Voltage Level
- System Health
- 5 User Activation/Panic Button
- Traction
- Location/Geofencing
- Driver Identification
- Remote Activation

10 **[0041]** Trigger event processing 104 essentially comprises three elements, a flow process for contacting a central control 106, contacting a claims dispatch, and/or recording trigger event data 110. Trigger event processing can include, but is not limited to:

- 15 Contact External Entities
- EMT (Emergency Medical Transport), Claims Dispatch, Other External Entity Takes Appropriate Action
- Record Sensor Information
- Transmission of Data
- Recalibration
- 20 Load Software

[0042] If trigger event processing comprises contact central control, the inquiry is made, and if affirmative, the central control is contacted 112, the central control can take appropriate action 114, and a record is made of the action taken by the central control 116.

25 **[0043]** For the process of claims dispatch 108, the system first contacts 120 the claims dispatch service department of the insurer, the claims dispatch takes appropriate action 122 and a recording 124 of the claims dispatch action information is made.

[0044] The recording of trigger event data can include, but is not limited to:

- 30 The Trigger
- Latitude
- Longitude
- Greenwich Mean Time
- Velocity
- 35 Acceleration
- Direction
- Vehicle Orientation
- Seatbelt Status

40 Data capture processing concludes with end step 130.

[0045] The recording thus comprises monitoring a plurality of raw data elements, calculated data elements and derived data elements as identified above. Each of these is representative of an operating state of the vehicle or an action of the operator. Select ones of the plurality of data elements are recorded when the ones are determined to have an identified relationship to the safety standards. For example, vehicle speed in excess of a predetermined speed limit will need to be recorded but speeds below the limit need only be monitored and stored on a periodic basis. The recording may be made in combination with date, time and location. Other examples of data needed to be recorded are excessive rates of acceleration or frequent hard braking.

45 **[0046]** The recording process would be practically implemented by monitoring and storing the data in a buffer for a selected period of time, e.g., thirty seconds. Periodically, such as every two minutes, the status of all monitored sensors for the data elements is written to a file which is stored in the vehicle data storage within the computer 300. The raw, calculated and derived data elements listed above comprise some of the data elements to be so stored.

50 **[0047]** "Trigger events" should be appreciated as a combination of sensor data possibly requiring additional action or which may result in a surcharge or discount during the insurance billing process. Certain trigger events may require immediate upload 106 to a central control which will then be required to take appropriate action 114. For example, a trigger event would be rapid deceleration in combination with airbag deployment indicating a collision, in which case the system could notify the central control of the vehicle location. Alternatively, if the operator were to trigger on an emergency light, similarly the system could notify the central control of the vehicle location indicating that an emergency is occurring.