

# *Application of a Clustering Adaptive Fuzzy Logic Controller in a Brushless DC Drive*

James P. Johnson,  
Student Member, IEEE

K.M. Rahman,  
Student Member, IEEE

M. Ehsani,  
Fellow, IEEE

Power Electronics Laboratory  
Texas A&M University  
College Station, Texas

## **Abstract:**

*A Clustering Adaptive Fuzzy Logic System (CAFLS) is proposed as a high performance controller in a brushless d.c. (BLDC) motor drive. Objectives of the proposed system include elimination of speed ripple due to cogging at low speeds under heavy load, as well as good dynamic response. The CAFLS implemented has advantages of computational simplicity, and self-tuning characteristics.*

## **Introduction:**

Recent trends toward increased efficiency, compactness, and reduced package weight point toward the pulse-width modulated (PWM) voltage source inverter (VSI) driven permanent magnet BLDC motor drive as being the most cost effective solution for 10 KW and under variable speed motion control. In [1], recent applications were cited: hvac systems, fans, pumps, washers, dryers, treadmills and other exercise equipment, wheelchairs, people carriers in airports, golf carts, freezers, refrigerators, automotive components, handtools, and industrial process drives. To eliminate the need for mechanical gearing in many of these applications, a drive with low-speed high torque capabilities and negligible torque ripple is desired. Torque ripple in BLDCs is primarily an effect of three causes: 1. cogging - due to the discretely pulsed operation of the BLDC and its stator field - permanent magnet interactions at low-speeds, 2. ripple due to deviances of the back-emf (BEMF) from its ideal trapezoidal shape, and 3. ripple due to the commutation instants throughout the speed range but usually negated by inertial effects at higher speeds [2]. In the cited reference it was noted that cogging can be reduced by skewing by one slot pitch, however this leads to an increase in ripple due to the second kind previously mentioned.

Recent efforts to reduce torque ripple in BLDC drives are typically focused on manipulating and distorting the current waveforms. Simulations based on prescribed current

reference functions shaped according to the particular BEMF shape are described in [3]. Calculations of inverse ripple currents from coefficients stored in lookup tables to reduce torque ripple currents was effective in simulations in [4], however a dynamically variable reference model of considerable complexity and a priori knowledge of the plant model was required for its implementation. The authors of [5] and [6] proposed similar methods of ripple reductions using direct current control based on a one-step ahead current predictor, requiring system model information in the construction of torque observers. Other literature concerning torque ripple reduction includes the calculation of torque ripple harmonics with the FFT, and the generation of variable structure controllers.

Fuzzy logic, while developed over 30 years ago, has only recently emerged as a useful tool in industrial control applications. Many texts and papers exist explaining the fundamentals of fuzzy logic usage, e.g. [7-10]. Some recent uses of fuzzy logic have included measures of adaption and will be denoted Adaptive Fuzzy Logic Systems (AFLS). One method of conventional adaptive control, the model reference adaptive control (MRAC) uses an adapting plant model, or identifier, to provide states which should be equal to those produced by the actual system. A reference model, or plant model producing the desired output provides an output signal which is compared to that of the actual system which then produces an error. The error generated is then used by an adaptive control law which modifies a controller in cascade with the plant. The error between the identifier output and the actual plant output is used to update the identifier model, making it more closely emulate the actual plant. Recent uses of AFLS in motion control systems have made use of the concepts of MRAC. [10] utilized a fuzzy logic controller within a conventional MRAC. The authors reported their method to be faster than a conventional MRAC (without a fuzzy controller) while possessing the ability to adapt to parameter variations in such a manner that tracking errors were eliminated. In [11], a fuzzy controller and a fuzzy system acting as the model in a MRAC scheme were

0-7803-3932-0

implemented. A third use of fuzzy logic combined with MRAC, [12], utilized the inherent adaptive capability of the fuzzy logic system by implementing it as the MRAC system's adaptive mechanism. In this paper, the method of control and ripple reduction at low-speeds are based on the use of a CAFLS. The proposed controller requires no model of the system to be controlled, and is especially suited for systems where few input / output data are known a priori for training purposes. Similar systems have outperformed the tracking capabilities of conventional MRAC systems [8].

[8] previously developed an optimal adaptive fuzzy logic system (OAFLS). The system used in this paper applies this OAFLS with some modifications and external controlling algorithm. The basic elements of the fuzzy system are the fuzzifier, rule-base, and defuzzifier. As discussed in [7-10] these elements are available in many different forms. The OAFLS of the proposed system is described in the following section. Subsequent sections include a development of the proposed system, simulation results, experimental setup, and conclusions.

**Proposed System:**

A block diagram of the proposed system is shown in Figure 1. The system consists of a BLDC with encoder driven by a six-step inverter, commutation logic and current limiting external to the microcontroller. Internal to the microcontroller is an interrupt-driven routine which provides gating signals, speed calculations from encoder information, a PWM generator, and the sliding CAFLS. The sliding CAFLS follows the flow chart of Figure 2 and equations which follow. The "sliding" feature of the CAFLS is a memory windowing system which allows different sets of clusters to be used depending on actual speed and load. This allows the clusters to more closely position themselves according to system dynamics and desired control action. The CAFLS is an adaptive fuzzy system which is especially suitable for systems where few input/output sets are known a priori. In this system the input sets consist of a set of n consecutive speed error samples. The output is a change in PWM duty cycle for the given inputs which alters the PWM so as to optimally correct the dynamic response. The system initially starts with a small number of input/output sets which are the initial clusters. As input is provided to a given window's clusters, the input is compared with the clusters and the norm (distance) from the input is determined for each cluster. The distances from each of the clusters is compared to a specified radius. If all distances are greater than the radius then either a new cluster must be made with the input as its center or the radius must be increased if no space is left to add clusters. If any distance is less than the radius then the cluster having the least distance absorbs the input and updates its output coefficients while all other clusters remain

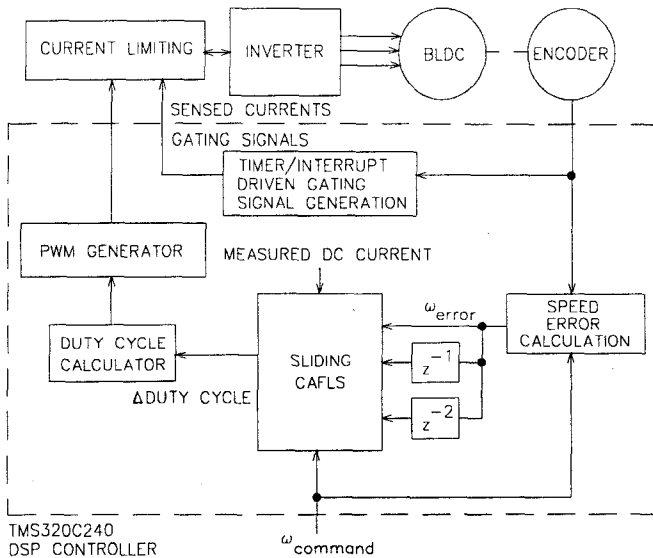

Figure 1. Overall System Block Diagram

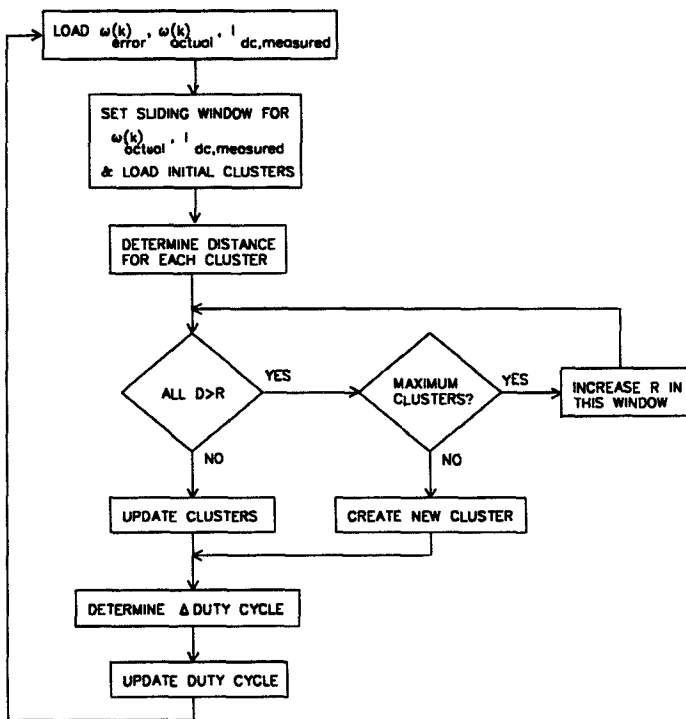

Figure 2. Sliding CAFLS Flow Chart

unchanged. A defuzzification of the input provides a crisp output. Given the following definitions, the CAFLS follows in equation form:

**DEFINITIONS:**

- $\bar{X}_k$ : vector of inputs after sample k
- $\bar{C}_n$ : nth cluster structure consisting of
  - $\bar{X}_{Cn}$ : nth cluster structure inputs
  - $Y_{Cn}$ : nth cluster structure output
  - $U_{Cn}$ : nth cluster coefficient

After each sample, k, update  $\bar{X}_k = [x(k-m), x(k-m+1), \dots, x(k)]$ , compare the input vector to each cluster in the window,  $|\bar{X}_k - \bar{X}_{Cn}|$ , to determine distances,  $D_m$ , where  $|w|$  is the norm of w, and m is the number of established clusters in the window.

Determine if radius has been exceeded by  $D_m$  :

If  $R = \text{radius} < \text{all } D_m$ , then create a new cluster u with  $\bar{X}_{Cu} = \bar{X}_k$ ,  $U_{Cu} = 1$ , and  $Y_{Cu} = f_{out}$  as subsequently defined.

- If  $R \geq D_m$  for any  $x(k-p)$ ,  $p=0,1, \dots, m$  then update  $\bar{X}_{Cn}$ ,
  - $Y_{Cn} = Y_{Cn} + f_{out}$  (1)
  - $U_{Cn} = U_{Cn} + 1$  (2)

defuzzify with

$$f_{out} = \frac{\sum_{\text{all } m} Y_{Cn} e^{-\left[\frac{|\bar{X}_k - \bar{X}_{Cn}|^2}{\gamma^2}\right]}}{\sum_{\text{all } m} U_{Cn} e^{-\left[\frac{|\bar{X}_k - \bar{X}_{Cn}|^2}{\gamma^2}\right]}} = \Delta \text{ PWM duty cycle} \quad (3)$$

which is an OAFLS with singleton fuzzifier, Gaussian membership functions whose width is varied by user defined  $\gamma$ , a product-inference rule, and a center-average defuzzification process [8].

The initial clusters for the windows are constructed by utilizing a system model based on the manufacturer's specifications. The initial usage of this system, as was shown in Figure 1 was as a feedback controller. A natural adaptiveness of this controller is in the ability of the CAFLS to cluster new inputs around a given number of cluster centers. Optimal values of radius and  $\gamma$  were chosen off-line. A more complex approach is to update each window's clusters by an on-line adaptive series-parallel identifier. The

identifier, as described in [8], uses a back-propagation algorithm to update its parameters. An accurate model of the system is maintained as the identifier/fuzzy controller is continually updated. The parameter vectors which are adaptively updated are  $[\bar{X}_{Cn}, \gamma_n]$ . The design of the adaptive laws have been shown in [8]. A reference model may be chosen as any desired function such as,

$$\omega[k] = 2.671504\omega[k-1] - 2.350451\omega[k-2] + 0.6787992\omega[k-3] + 3.794871e-2V[k-1] + 1.004261e-4V[k-2] - 3.122917e-V[k-3]$$

where V is the command speed  
 $\omega$  is the actual speed

which acts as the original system modified by a lead compensator. The final output of the system is obtained as the the OAFLS output which acts a an adaptive system identifier / controller is applied as the duty cycle of the PWM applied in the drive. Practical upper and lower limits of PWM are enforced which act as additional linguistic rules. On-line monitoring of the current level ( $\propto$  load during constant speed/load operation), and updating the particular CAFLS corresponding to the load during constant speed operation, causes the adaptive identifier/fuzzy controller parameters to closely track those of the actual plant. For the proposed system all clusters are of equal size, with a 4 element input vector consisting of 3 consecutive speed error values and the command speed. The size of the clusters, and maximum number of clusters is arbitrary, limited only by system storage resources. As in Figure 2, the radius R may be varied as cluster limits are met. The smaller the R, the greater the granularity of the clusters and the greater the possibility new clusters will be formed. The parameter  $\gamma$  in (3) is used to enhance the accuracy of the solution of the OAFLS. Larger  $\gamma$  tends to allow the OAFLS to generalize and tends to smooth the recalled output for a given input/output data set, while a smaller  $\gamma$  tends to provide a more accurate output, but has less generalizing capability to new input.

**Simulation Results:**

A C program was used to simulate a BLDC drive model with a CAFLS in a feedback controller configuration. The initial cluster values were obtained with an off-line optimal control algorithm using the simulation model under varying load conditions prior to starting the CAFLS control. The objective of the CAFLS was reduction of speed ripple at low speeds with a heavy load while maintaining satisfactory dynamic response. Figure 3 shows the speed response of the optimal, the CAFLS, and a PI control for a speed setpoint of 100 rpm with a constant (3/4)\*rated load. Figure 4 shows a cycle of the current waveforms for one phase for each of these simulations.

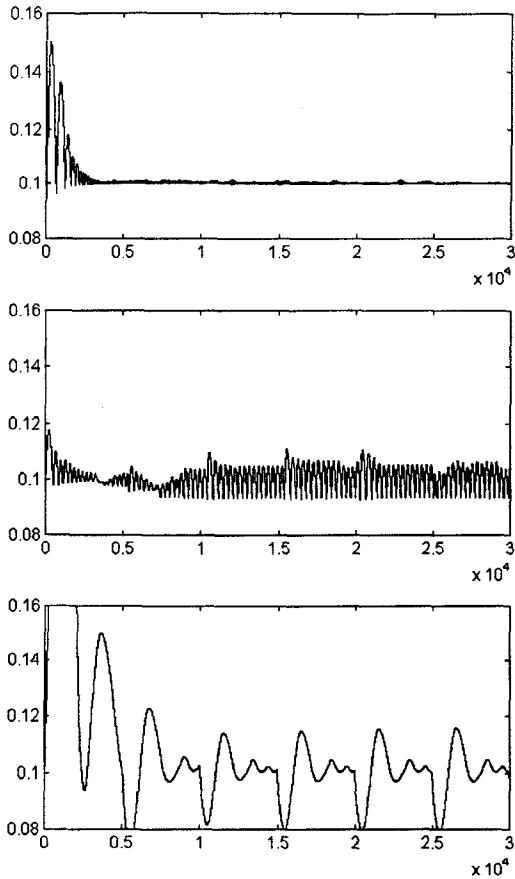

Figure 3. Step load responses of the BLDC system with (top) the optimal controller, (middle) the CAFLS controller, and (bottom) the PI controller {units: abscissa::time step [1e-5 s];ordinate::speed [krpm]}.

### Experimental Setup:

The system which is being used to experimentally verify the simulation results is shown in the block diagram of Figure 1. The DSP Controller used is a Texas Instruments TMS320F240 ('F240) which is based on the fixed point C2xx core architecture. With the capabilities of this DSP Controller, it can be used as a virtual one-chip controller. This DSP Controller is specially designed with power and machine control in mind. Included are all of the standard power electronics peripherals with the processing speed of a DSP (up to a 20 MHz CPU clock with dual memory access in a single clock cycle possible). Included on the 'F240 are 64K memory, two 8-channel multiplexed 10-bit A/D ports, 3 independent 16-bit timers with six modes of counting possible, 4 capture units - two of which can be programmed as quadrature encoder pulse (QEP) inputs, 12 compare units,

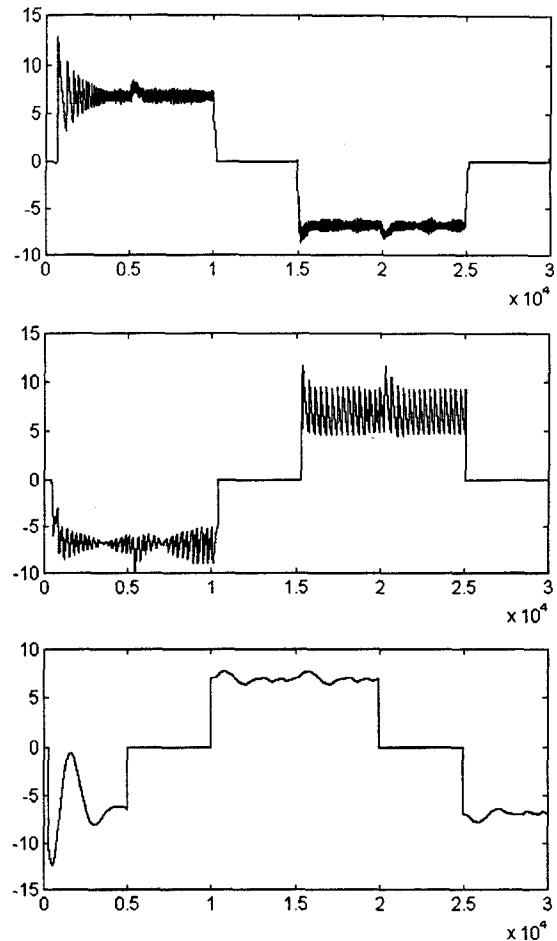

Figure 4. The initial current waveforms during the step load responses of the BLDC system (Figure 3) with (top) the optimal controller, (middle) the CAFLS controller, and (bottom) the PI controller {units: abscissa::time step [1e-5 s];ordinate::current [A]}.

the ability to generate up to 9 independent PWM outputs, 28 individually programmable digital I/O pins, serial communications capability, memory expansion ability, a highly flexible choice of interrupt capabilities, and more.

BLDC control with the 'F240 was implemented with incremental encoder feedback. One of the capture units was used with a timer/counter as the QEP channel A and B inputs and a third capture and interrupt as the index pulse timer/counter reset. The 3 full compare units of the 'F240 provided 3 independent PWM channels on 6 output pins, used as the gating signals for the 6-step inverter by masking and unmasking the appropriate gating signals with an "action control register" of the 'F240 according to the commutation signals required in synchronization with the QEP position information. Current sensing information was easily

accessed through the A/D ports of the 'F240. The inverter is a six-step MOSFET inverter with current limiting with an option of hysteresis current control. The 3-phase, 4-pole, BLDC used is rated at 1 HP, and is attached in a direct-drive configuration to a 600 cpr 3-channel optical encoder and 1 HP DC motor load. Experimental results will be available in subsequent work, possibly by the date of the conference. Experimental results will include an analysis of the reduction of speed ripple at low speed under heavy load and the insensitivity of the CAFLS controller to load disturbances.

#### Conclusions:

A BLDC speed controller with the goal of reducing speed ripple at low speeds with heavy loading was presented. Simulation results showed that the speed ripple and dynamic response of the system using a CAFLS as a feedback controller was superior to the PI controlled system, but not as good as the optimal control for constant speed operations. The CAFLS system outperformed the optimally controlled system and the PI controlled system during the initial step response (dynamic response), even though the CAFLS used the data of the optimal system to train. This was believed due to the generalizing ability of the CAFLS. Future work will focus on implementation of the CAFLS as a feedback controller and in an MRAC type system as described in the "Proposed System" part of this paper. Implementation will emphasize a minimal component type system by using the newly developed TMS320F240 with a small number of additional buffering type i.c.'s, inverter and current sensing and limiting circuitry.

#### Acknowledgements:

The support of Texas Higher Education Coordinating Board Advanced Technology Program, TRW Electronic Controlled Steering, General Motors Research Laboratories, and Texas Instruments Digital Control Systems Division, for this research is gratefully acknowledged.

#### References:

[1] Krishnan, R., Lee, S., Monajemy, R. "Modeling, Dynamic Simulation and Analysis of a C- Dump Brushless DC Motor Drive" Conference Proceedings of the Eleventh Annual Applied Power and Electronics Conference and Exposition. APEC '96. IEEE. N.Y. 1996.

[2] Sebastian, T., Gangla V. "Analysis of Induced EMF Waveforms and Torque Ripple in a Brushless Permanent Magnet Machine" IEEE Transactions on Industrial Applications, Vol. 32, No. 1, January/February 1996.

[3] Kang, C., Ha, I. "An Efficient Torque Control Algorithm for BLDCM with a General Shape of Back EMF" Proceedings of IEEE 24th Annual Power Electronics Specialist Conference. PESC '93. IEEE N.Y. 1993.

[4] Lee, C., Kwok, N. "Torque Ripple Reduction in Brushless DC Motor Velocity Control System Using a Cascade Modified Model Reference Compensator" Proceedings of IEEE 24th Annual Power Electronics Specialist Conference. PESC '93. IEEE N.Y. 1993.

[5] Kang, S., Sul S. "Direct Torque Control of the Brushless DC Motor with Non-ideal Trapezoidal Back EMF" IEEE Transactions on Power Electronics. v.10. issue 6. p.796-802. IEEE N.Y. 1995.

[6] Huh, U., Lee, J., Lee, T. "A Torque Control Strategy of Brushless DC Motor With Low Resolution Encoder" Proceedings of 1995 International Conference on Power Electronics and Drive Systems. PEDS '95. IEEE N.Y. 1995.

[7] Tang, Y., Xu, L. "Fuzzy Logic Application for Intelligent Control of a Variable Speed Drive" IEEE Transactions on Energy Conversion. v.9p.679-85. IEEE N.Y. December 1994.

[8] Wang, L. "Adaptive Fuzzy System and Control - Design and Stability Analysis" Prentice Hall. Englewood Cliffs, N.J. 1994.

[9] Jamshidi, M., Vadiie, N., Ross, T. "Fuzzy Logic and Control - Software and Hardware Applications" Prentice Hall. Englewood Cliffs, N.J. 1993.

[10] Cerruto, E., Consoli, A., Raciti, A., Testa, A. "Adaptive Fuzzy Control of High Performance Motion Systems" Proceedings of the 1992 International Conference on Industrial Electronics, Control, Instrumentation, and Automation. IEEE N.Y. 1992.

[11] Huy, H. "An Adaptive Fuzzy Controller For Permanent-Magnet A.C. Servo Drives" Conference Record of the 1995 IEEE Industry Applications Conference. IEEE N.Y. 1995.

[12] Kovacic, Z., Bogdan, S., Cmosija, P. "Fuzzy Rule-Based Model Reference Adaptive Control of Permanent-Magnet Synchronous Motor Drive" Proceedings of the IECON '93 International Conference on Industrial Electronics, Control, and Instrumentation. IEEE. N.Y. 1993.