

EXHIBIT 3



(12) **United States Patent**
Hunter

(10) **Patent No.:** **US 6,430,603 B2**
(45) **Date of Patent:** ***Aug. 6, 2002**

(54) **SYSTEM FOR DIRECT PLACEMENT OF COMMERCIAL ADVERTISING, PUBLIC SERVICE ANNOUNCEMENTS AND OTHER CONTENT ON ELECTRONIC BILLBOARD DISPLAYS**

(75) Inventor: **Charles Eric Hunter**, Hilton Head Island, SC (US)

(73) Assignee: **World Theatre, Inc.**, Morrisville, NC (US)

(*) Notice: This patent issued on a continued prosecution application filed under 37 CFR 1.53(d), and is subject to the twenty year patent term provisions of 35 U.S.C. 154(a)(2).

Subject to any disclaimer, the term of this patent is extended or adjusted under 35 U.S.C. 154(b) by 0 days.

4,761,641 A	8/1988	Schreiber
4,812,843 A	3/1989	Champion, III et al.
5,214,793 A	5/1993	Conway et al.
5,233,423 A	8/1993	Jernigan et al.
5,257,017 A	10/1993	Jones et al.
5,274,762 A	12/1993	Peterson et al.
5,469,020 A	11/1995	Herrick
5,486,819 A	1/1996	Horic
5,543,856 A	8/1996	Rosser et al.
5,612,741 A	3/1997	Loban et al.
5,630,067 A	5/1997	Kindell et al.
5,644,859 A	7/1997	Hsu
5,724,062 A	3/1998	Hunter
5,781,734 A	7/1998	Ohno et al.
5,845,083 A	12/1998	Hamadani et al.
5,848,129 A	12/1998	Baker
5,898,384 A *	4/1999	Alt et al. 340/825.36
5,934,795 A *	8/1999	Rykowski et al. 362/309
5,992,888 A *	11/1999	North et al. 283/56
6,073,372 A *	6/2000	Davis 40/124.16

OTHER PUBLICATIONS

Steven A. Morley, "Making Digital Cinema Actually Happen—What It Takes and Who's Going to Do It", *Qualcomm Incorporated*, Oct. 31, 1998.

* cited by examiner

Primary Examiner—Thomas R. Peeso
(74) *Attorney, Agent, or Firm*—Finnegan, Henderson, Farabow, Garrett & Dunner, I.L.P

(57) **ABSTRACT**

Commercial advertisers, such as consumer product companies and the advertising agents that represent them, directly access a network of thousands of large, high resolution electronic displays located in high traffic areas and directly send their own advertisements electronically to the network to be displayed at locations and times selected by the advertisers.

74 Claims, 2 Drawing Sheets

- (21) Appl. No.: **09/301,102**
- (22) Filed: **Apr. 28, 1999**
- (51) **Int. Cl.**⁷ **G06F 15/16**
- (52) **U.S. Cl.** **709/207; 709/217; 709/219; 709/227; 705/26; 705/27**
- (58) **Field of Search** **709/207, 217, 709/218, 219, 227, 234, 238, 240; 705/26, 27**

- (56) **References Cited**
- U.S. PATENT DOCUMENTS**
- | | | |
|-------------|---------|-------------------|
| 3,373,517 A | 3/1968 | Halperin |
| 3,376,465 A | 4/1968 | Corpew |
| 3,941,926 A | 3/1976 | Slobodzian et al. |
| 4,368,485 A | 1/1983 | Midland |
| 4,559,480 A | 12/1985 | Nobs |
| 4,734,779 A | 3/1988 | Levis et al. |

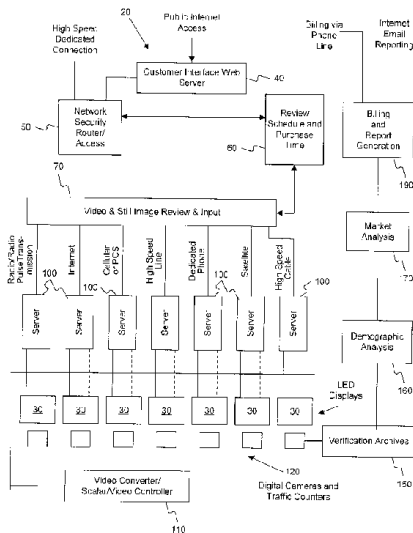

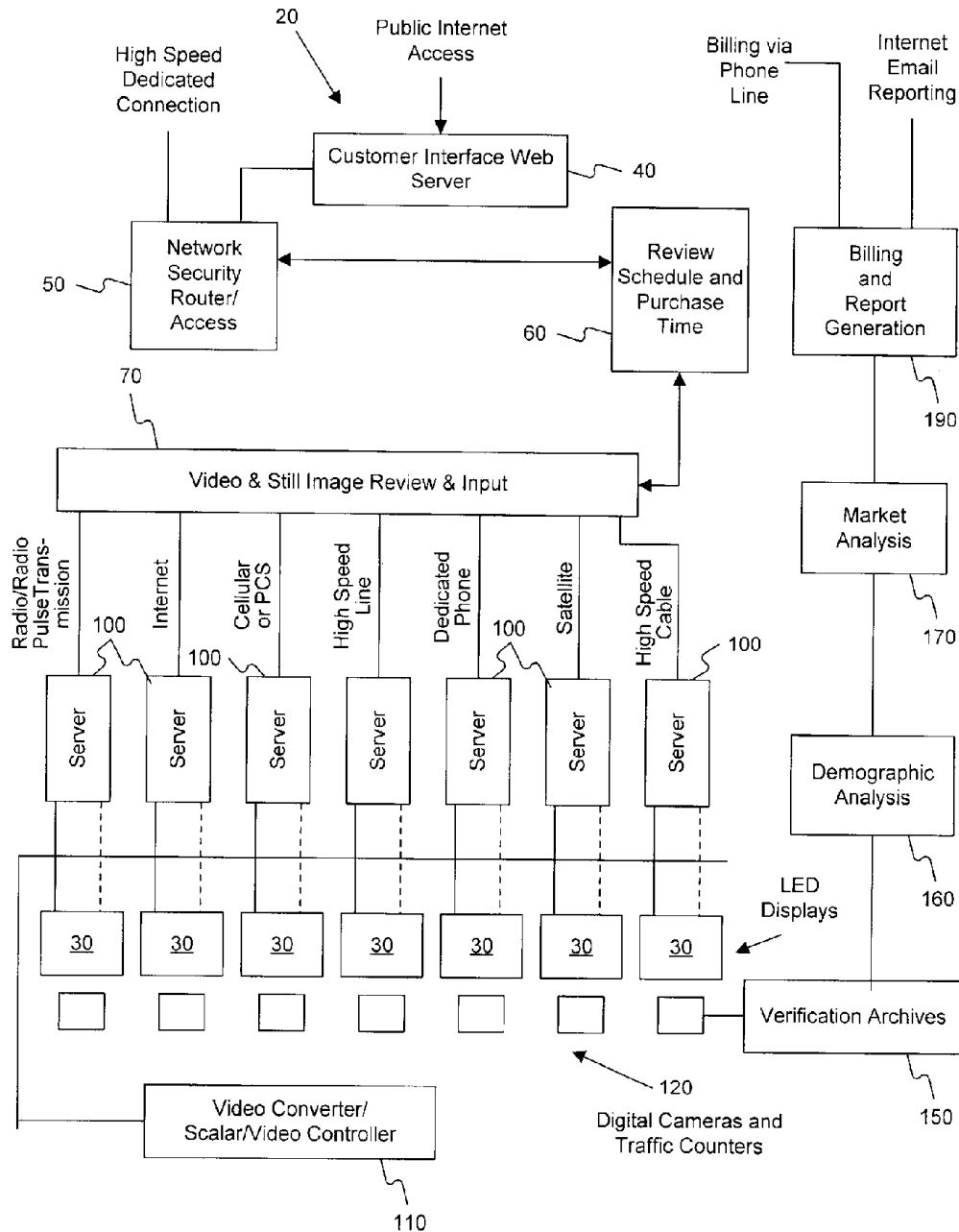

Fig. 1

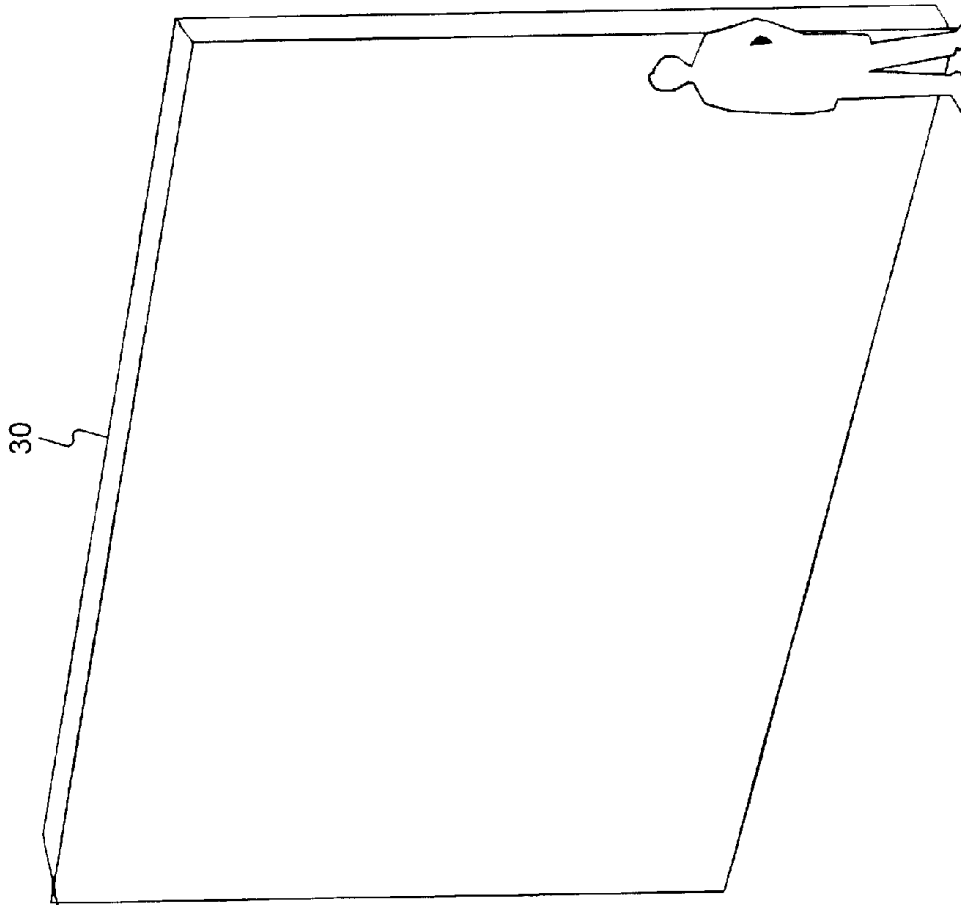
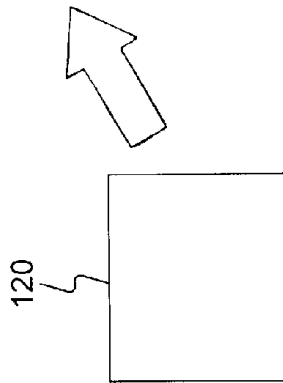

Fig. 2



US 6,430,603 B2

1

**SYSTEM FOR DIRECT PLACEMENT OF
COMMERCIAL ADVERTISING, PUBLIC
SERVICE ANNOUNCEMENTS AND OTHER
CONTENT ON ELECTRONIC BILLBOARD
DISPLAYS**

FIELD OF THE INVENTION

The invention relates to systems permitting advertisers to target geographical regions and demographic groups with ever changing, current advertising content without incurring the high fixed cost of traditional single-message billboards. More particularly, the invention relates to a system and method permitting commercial advertisers, such as consumer product companies and the advertising agents that represent them, to directly access a network of thousands of large, high resolution electronic displays located in high traffic areas and to directly send their own advertisements electronically to the network to be displayed at locations and times selected by the advertiser.

BACKGROUND OF THE INVENTION

Consumer product advertising takes many forms, such as television commercials, newspaper and magazine advertisements, mailings, point-of-sale displays, outdoor billboards, etc. Using current advertising media, advertisers engage in a constant struggle to efficiently use their budgets to most effectively reach their geographic and demographic targets.

Focusing on the outdoor advertising component of advertising by consumer product companies, it is well known that outdoor billboards have traditionally taken the form of single-message displays formed of printed sheets or painted surfaces containing the advertising content adhered to a flat backing. This time-honored outdoor advertising technique has remained essentially unchanged throughout the twentieth century. The high cost of printing, transporting and mounting a message on a conventional billboard has dictated that the same message remain in place for a considerable period of time. Thus, a conventional billboard cannot be readily changed to reflect current events within the geographic area of the billboard. Additionally, the content on a conventional billboard tends to become essentially "invisible" as a part of the landscape after its content has been in place for a relatively short period of time, especially to commuters and others who regularly pass the billboard. Beyond the above problems with cost, single-message content, lack of content changeover capability, and the like, conventional outdoor billboards have come under increasing criticism because in their large numbers, and often tattered condition, they clutter highways with a distasteful form of visual "pollution". A reduction in the number of billboards and improvement of the appearance of those that remain, if accomplished while increasing the overall advertising impact afforded by outdoor advertising, would please virtually everyone.

The use of electronic billboards has been suggested, for example, in U.S. Pat. No. 5,612,741. However, there is no electronic billboard network in operation whereby commercial advertisers may directly place ads onto selected billboards at selected times through direct access to a master network. Such a network, properly designed and operated, promises to overcome the numerous disadvantages currently associated with the outdoor advertising industry, while also meeting the above-enumerated needs of consumer products advertisers.

SUMMARY OF THE INVENTION

According to the present invention, commercial advertisers, such as consumer product companies and the

2

advertising agents that represent them, directly access a network of multiple large, high resolution electronic displays located in high traffic areas and directly send their own advertisements electronically to the network to be displayed at locations and times selected by the advertisers. In preferred embodiments, the system of the invention includes a central information processing center that permits customers to review a schedule of times and electronic display locations that are available for placement of advertisements, and also permits customers to purchase available times at selected electronic display locations for placement of their advertising content. The customer then transmits his video or still image advertising content to the processing center where the content is reviewed for appropriateness and then transmitted to the customer-selected electronic display(s). The electronic displays preferably are large (e.g., 23x33½ ft.) flat LED displays that are driven by their own video or image servers. Verification that the advertisements run as ordered is facilitated by an information storage module or, more preferably, by a digital camera or series of digital cameras. A traffic counter may be used to determine the traffic that passed by the display while the advertisement was running. Bills and reports containing market and demographic analysis are generated and sent to the customer.

BRIEF DESCRIPTION OF THE DRAWINGS

Some of the features of the invention having been stated, other features will appear as the description proceeds, when taken in connection with the accompanying drawings, in which

FIG. 1 is a block diagram showing the principal components of an electronic display network constructed in accordance with the present invention.

FIG. 2 is a view of one of the electronic displays of the network of FIG. 1.

DETAILED DESCRIPTION OF THE
INVENTION

While the present invention will be described more fully hereinafter with reference to the accompanying drawings, in which aspects of the preferred manner of practicing the present invention are shown, it is to be understood at the outset of the description which follows that persons of skill in the appropriate arts may modify the invention herein described while still achieving the favorable results of this invention. Accordingly, the description which follows is to be understood as being a broad, teaching disclosure directed to persons of skill in the appropriate arts, and not as limiting upon the present invention.

Referring to the drawings, and particularly to FIG. 1, there is shown a block diagram of a system **20** for direct placement of commercial advertisements, public service announcements and other content on electronic displays. System **20** includes a network comprising a plurality of electronic displays **30** that are located in high traffic areas in various geographic locations. The displays may be located in areas of high vehicular traffic, and also at indoor and outdoor locations of high pedestrian traffic, as well as in movie theaters, restaurants, sports arenas, casinos or other suitable locations. Thousands of displays, up to 10,000 or more displays worldwide, may be networked according to the present invention. In preferred embodiments, each display is a large (for example, 23 feet by 33½ feet), high resolution, full color display that provides brilliant light emission from a flat panel screen.

A customer of system **20**, for example an in-house or agency representative of a consumer products company,

Explore Litigation Insights

Docket Alarm provides insights to develop a more informed litigation strategy and the peace of mind of knowing you're on top of things.

Real-Time Litigation Alerts



Keep your litigation team up-to-date with **real-time alerts** and advanced team management tools built for the enterprise, all while greatly reducing PACER spend.

Our comprehensive service means we can handle Federal, State, and Administrative courts across the country.

Advanced Docket Research



With over 230 million records, Docket Alarm's cloud-native docket research platform finds what other services can't. Coverage includes Federal, State, plus PTAB, TTAB, ITC and NLRB decisions, all in one place.

Identify arguments that have been successful in the past with full text, pinpoint searching. Link to case law cited within any court document via Fastcase.

Analytics At Your Fingertips



Learn what happened the last time a particular judge, opposing counsel or company faced cases similar to yours.

Advanced out-of-the-box PTAB and TTAB analytics are always at your fingertips.

API

Docket Alarm offers a powerful API (application programming interface) to developers that want to integrate case filings into their apps.

LAW FIRMS

Build custom dashboards for your attorneys and clients with live data direct from the court.

Automate many repetitive legal tasks like conflict checks, document management, and marketing.

FINANCIAL INSTITUTIONS

Litigation and bankruptcy checks for companies and debtors.

E-DISCOVERY AND LEGAL VENDORS

Sync your system to PACER to automate legal marketing.