

# Exhibit 1



US008677398B2

(12) **United States Patent**  
**Shkedi**

(10) **Patent No.:** **US 8,677,398 B2**  
(45) **Date of Patent:** **\*Mar. 18, 2014**

(54) **SYSTEMS AND METHODS FOR TAKING ACTION WITH RESPECT TO ONE NETWORK-CONNECTED DEVICE BASED ON ACTIVITY ON ANOTHER DEVICE CONNECTED TO THE SAME NETWORK**

(75) Inventor: **Roy Shkedi**, New York, NY (US)

(73) Assignee: **Intent IQ, LLC**, New York, NY (US)

(\* ) Notice: Subject to any disclaimer, the term of this patent is extended or adjusted under 35 U.S.C. 154(b) by 14 days.  
This patent is subject to a terminal disclaimer.

(21) Appl. No.: **13/167,605**

(22) Filed: **Jun. 23, 2011**

(65) **Prior Publication Data**

US 2011/0252441 A1 Oct. 13, 2011

**Related U.S. Application Data**

(63) Continuation of application No. 12/860,666, filed on Aug. 20, 2010, now Pat. No. 8,281,336, which is a continuation of application No. 11/736,544, filed on Apr. 17, 2007, now Pat. No. 7,861,260.

(51) **Int. Cl.**  
**H04N 7/10** (2006.01)

(52) **U.S. Cl.**  
USPC ..... **725/34; 725/36; 709/218; 705/14; 705/14.49; 705/14.53; 705/14.54; 705/14.66**

(58) **Field of Classification Search**  
USPC ..... **725/34-36; 709/218; 705/14, 14.25, 705/14.4, 14.41, 14.49, 14.53, 14.54, 14.55, 705/14.66, 14.73**

See application file for complete search history.

(56) **References Cited**

U.S. PATENT DOCUMENTS

5,105,184 A	4/1992	Pirani et al.
5,809,242 A	9/1998	Shaw et al.
5,848,396 A	12/1998	Gerace
5,855,008 A	12/1998	Goldhaber et al.
5,901,287 A	5/1999	Bull et al.
5,933,811 A	8/1999	Angles et al.

(Continued)

FOREIGN PATENT DOCUMENTS

JP	2006-324763	11/2006
JP	2007-274246	10/2007

(Continued)

OTHER PUBLICATIONS

U.S. Appl. No. 12/912,726, filed Oct. 26, 2010

(Continued)

*Primary Examiner* — Nnenna Ekpo

(74) *Attorney, Agent, or Firm* — Louis J. Hoffman; David S. Alavi

(57) **ABSTRACT**

In a method for delivering targeted television advertisements based on online behavior, IP addresses indicating online access devices and IP addresses indicating television set-top boxes are electronically associated for a multitude of users. Using user profile information derived from online activity from one of the online access IP addresses, a television advertisement is selected, such as by using behavioral targeting or demographic information, and automatically directed to the set-top box indicated by the set-top IP address associated with that online access IP address. Preferably neither the user profile information nor the electronic association of online access and set-top box IP addresses includes personally identifiable information.

**44 Claims, 18 Drawing Sheets**

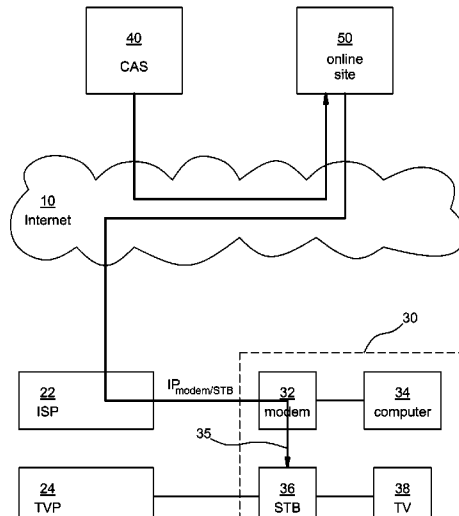

(56)

References Cited

U.S. PATENT DOCUMENTS

5,948,061	A	9/1999	Merriman et al.	2002/0194058	A1	12/2002	Eldering et al.
5,978,013	A	11/1999	Jones et al.	2002/0194604	A1	12/2002	Sanchez et al.
5,995,943	A	11/1999	Bull et al.	2003/0041156	A1	2/2003	Pickover et al.
6,018,768	A	1/2000	Ullman et al.	2003/0051242	A1	3/2003	Donnelly
6,026,368	A	2/2000	Brown et al.	2003/0066078	A1	4/2003	Bjorgan et al.
6,055,573	A	4/2000	Gardenswartz et al.	2003/0093792	A1	5/2003	Labeeb
6,073,241	A	6/2000	Rosenberg et al.	2003/0126597	A1	7/2003	Darby et al.
6,157,946	A	12/2000	Itakura et al.	2003/0135853	A1	7/2003	Goldman et al.
6,160,989	A	12/2000	Hendricks et al.	2003/0145323	A1	7/2003	Hendricks et al.
6,189,008	B1	2/2001	Easty et al.	2003/0149975	A1	8/2003	Eldering et al.
6,216,129	B1	4/2001	Eldering	2003/0187949	A1	10/2003	Bhatt et al.
6,327,574	B1	12/2001	Kramer et al.	2003/0208756	A1	11/2003	Macrae et al.
6,366,298	B1	4/2002	Haitsuka et al.	2003/0208758	A1	11/2003	Schein et al.
6,377,986	B1	4/2002	Philyaw	2003/0226141	A1	12/2003	Krasnow et al.
6,385,592	B1	5/2002	Angles et al.	2003/0229900	A1	12/2003	Reisman
6,446,261	B1	9/2002	Rosser	2004/0003406	A1	1/2004	Billmaier
6,463,533	B1	10/2002	Calamera et al.	2004/0010546	A1	1/2004	Klug et al.
6,463,585	B1	10/2002	Hendricks et al.	2004/0031058	A1	2/2004	Reisman
6,487,538	B1*	11/2002	Gupta et al. .... 705/14.66	2004/0073915	A1	4/2004	Dureau
6,490,587	B2	12/2002	Easty et al.	2004/0078809	A1	4/2004	Drazin
6,536,041	B1	3/2003	Knudson et al.	2004/0107437	A1	6/2004	Reichardt et al.
6,684,194	B1	1/2004	Eldering et al.	2004/0117827	A1	6/2004	Karaoguz et al.
6,718,551	B1	4/2004	Swix et al.	2004/0123314	A1	6/2004	Bova
6,771,290	B1	8/2004	Hoyle	2004/0163101	A1	8/2004	Swix et al.
6,832,207	B1	12/2004	Shkedi	2004/0172650	A1	9/2004	Hawkins et al.
6,845,396	B1	1/2005	Kanojia et al.	2005/0076393	A1	4/2005	Sussman
6,847,992	B1	1/2005	Haitsuka et al.	2005/0086112	A1	4/2005	Shkedi
6,868,392	B1	3/2005	Ogasawara	2005/0125289	A1	6/2005	Beyda et al.
6,925,440	B1	8/2005	Shkedi	2005/0125290	A1	6/2005	Beyda et al.
6,973,436	B1	12/2005	Shkedi	2005/0165638	A1	7/2005	Piller
7,013,290	B2	3/2006	Ananian	2005/0165643	A1	7/2005	Wilson et al.
7,051,351	B2	5/2006	Goldman et al.	2005/0165644	A1	7/2005	Beyda et al.
7,072,853	B2	7/2006	Shkedi	2005/0177420	A1	8/2005	Tanahashi
7,092,926	B2	8/2006	Cerrato	2005/0187823	A1	8/2005	Howes
7,100,183	B2	8/2006	Kunkel et al.	2005/0229215	A1	10/2005	Schein et al.
7,152,237	B2	12/2006	Flickinger et al.	2006/0116924	A1	6/2006	Angles et al.
7,158,943	B2	1/2007	Van der Riet	2006/0137015	A1	6/2006	Fahrny et al.
7,188,085	B2	3/2007	Pelletier	2006/0212350	A1*	9/2006	Ellis et al. .... 705/14
7,260,823	B2	8/2007	Schlack et al.	2006/0253323	A1	11/2006	Phan et al.
7,428,493	B2	9/2008	Shkedi	2006/0259357	A1	11/2006	Chiu
7,454,364	B2	11/2008	Shkedi	2006/0271953	A1	11/2006	Jacoby et al.
7,747,745	B2	6/2010	Shkedi	2007/0027850	A1*	2/2007	Chan et al. .... 707/3
7,756,744	B2	7/2010	Schiff et al.	2007/0033269	A1	2/2007	Atkinson et al.
7,822,637	B2	10/2010	Shkedi	2007/0038516	A1	2/2007	Apple et al.
7,822,639	B2	10/2010	Shkedi	2007/0073585	A1	3/2007	Apple et al.
7,856,372	B2	12/2010	Ullah	2007/0078774	A1	4/2007	Brown
7,856,373	B2	12/2010	Ullah	2007/0089127	A1	4/2007	Flickinger et al.
7,861,260	B2	12/2010	Shkedi	2007/0100690	A1	5/2007	Hopkins
7,890,609	B2	2/2011	Shkedi	2007/0115389	A1	5/2007	McCarthy et al.
7,913,275	B2	3/2011	Hendricks et al.	2007/0143786	A1	6/2007	Deutsch et al.
7,937,383	B2	5/2011	Hintze et al.	2007/0157228	A1	7/2007	Bayer et al.
7,966,647	B1	6/2011	Igoe et al.	2007/0198532	A1	8/2007	Krikorian
7,971,260	B2	6/2011	Spalink et al.	2007/0208619	A1	9/2007	Branam et al.
7,979,307	B2	7/2011	Shkedi	2007/0220553	A1	9/2007	Branam
8,015,286	B2	9/2011	Jenkins	2007/0233571	A1	10/2007	Eldering et al.
8,024,765	B2	9/2011	Ramanathan et al.	2007/0244750	A1	10/2007	Grannan et al.
8,051,444	B2	11/2011	Shkedi	2007/0266403	A1	11/2007	Ou et al.
8,079,048	B2	12/2011	Howcroft	2007/0277220	A1	11/2007	Shikuma et al.
8,086,491	B1	12/2011	Matz et al.	2007/0294401	A1	12/2007	Shkedi
2002/0010928	A1	1/2002	Sahota	2007/0294721	A1	12/2007	Haeuser et al.
2002/0013943	A1	1/2002	Haberman et al.	2008/0016540	A1	1/2008	Savoor et al.
2002/0032603	A1	3/2002	Yeiser	2008/0040742	A1*	2/2008	Howcroft et al. .... 725/34
2002/0046105	A1	4/2002	Gardenswartz et al.	2008/0109376	A1	5/2008	Walsh et al.
2002/0059602	A1	5/2002	Macrae et al.	2008/0109843	A1	5/2008	Ullah
2002/0078444	A1	6/2002	Krewin et al.	2008/0118063	A1	5/2008	Guzman et al.
2002/0082910	A1	6/2002	Kontogouris	2008/0181225	A1	7/2008	Zampello
2002/0104086	A1	8/2002	Tomsen et al.	2008/0189360	A1	8/2008	Kiley et al.
2002/0120933	A1	8/2002	Knudson et al.	2008/0201772	A1	8/2008	Mondaeev et al.
2002/0120935	A1	8/2002	Huber et al.	2008/0222283	A1*	9/2008	Ertugrul et al. .... 709/224
2002/0123928	A1	9/2002	Eldering et al.	2008/0243822	A1	10/2008	Campbell et al.
2002/0124249	A1	9/2002	Shintani	2008/0244076	A1	10/2008	Shah et al.
2002/0124253	A1	9/2002	Eyer et al.	2008/0255944	A1	10/2008	Shah et al.
2002/0129362	A1	9/2002	Chang et al.	2008/0275785	A1	11/2008	Altberg et al.
				2008/0313194	A1	12/2008	Shkedi
				2009/0037949	A1	2/2009	Birch
				2009/0049468	A1	2/2009	Shkedi
				2009/0049469	A1	2/2009	Small et al.

(56)

References Cited

U.S. PATENT DOCUMENTS

2009/0172723	A1	7/2009	Shkedi et al.
2009/0172728	A1	7/2009	Shkedi
2009/0204706	A1	8/2009	Ertugrul et al.
2009/0300675	A1	12/2009	Shkedi
2010/0076848	A1	3/2010	Stefanik et al.
2011/0035256	A1	2/2011	Shkedi
2011/0167043	A1	7/2011	Hintze et al.
2011/0258049	A1	10/2011	Ramer et al.
2012/0023522	A1	1/2012	Anderson

FOREIGN PATENT DOCUMENTS

KR	10-0793513	1/2008
KR	10-2009-0113456	8/2012
WO	WO2005046237	5/2005

OTHER PUBLICATIONS

U.S. Appl. No. 13/524,409, filed Jun. 15, 2012.

Engage Technologies, Inc.; Form S-1A; filed with the SEC; pp. 36-50; Jul. 19, 1999.

Chen, Andy; "Behavioral Matchmaking, Part 3: GPS and Behavioral Targeting"; from website <http://www.clickz.com>; Nov. 24, 2004.

Battelle, John; "The Search—How Google and Its Rivals Rewrote the Rules of Business and Transformed Our Culture"; pp. 167-171; 2005.

"BSkyB in Google Link-up"; Financial Times (FT.com); Dec. 6, 2006.

"Google moves into TV ads with BSkyB Deal"; Guardian Unlimited; Dec. 7, 2006.

Chen, Andy; "The New Behavioral Wunder"; from webpage <http://www.clickz.com>; Apr. 11, 2007.

"NetZero Launches Ad-Backed Access Service"; from website [www.clickz.com](http://www.clickz.com); Oct. 20, 1998.

"Nissan, BellSouth, Music Blvd. Among Latest Advertisers to Sign Up With NetZero"; press release from [www.irconnect.com](http://www.irconnect.com); Nov. 16, 1998.

"LookSmart and NetZero Extend and Enhance Winning Partnership"; press release found on [www.shareholder.com](http://www.shareholder.com); Feb. 9, 2000.

"NetZero Guarantees Increase in Web Site Traffic for New Advertisers"; press release from [www.irconnect.com](http://www.irconnect.com); circa 2000.

Saunders, Christopher; "NetZero to Launch Mobile Ad Platform"; from website [www.clickz.com](http://www.clickz.com); Mar. 29, 2001.

"180Solutions Launches All-In-One Online Ad Solution—Metricsdirect Outperforms Conventional Cost-Per-Click Models"; from [www.zango.com](http://www.zango.com); Mar. 30, 2004.

Keegan, Paul; "The Man Who Can Save Advertising"; from <http://money.cnn.com>; Nov. 1, 2004.

"Visible World Targets Advertising Industry"; from <http://informitv.com>; Feb. 20, 2005.

"Venture Market Summary"; VentureWire Alert; Mar. 29, 2005.

Olsen, S.; "TiVo is in talks with Internet search giants Google and Yahoo over possible deal . . . television and the Web . . ."; [www.news.com](http://www.news.com); Apr. 18, 2005.

"This Ad's for You—Just You"; BusinessWeek online; Jun. 28, 2005.

"Cable's Big Bet on Hyper-Targeting. Time Warner will test new software that sends different ads to different viewers."; BusinessWire online; Jul. 4, 2005.

"Comcast, Cox Buy Interactive TV Company"; from Yahoo.com Financial News; Jul. 13, 2005.

"TiVo Launches New Interactive Advertising Technology"; press release from [www.tivo.com](http://www.tivo.com); Jul. 18, 2005.

Grant, Peter; "To Ward Off New Competitors, Comcast Builds a Mini Internet"; Wall Street Journal online; Oct. 13, 2005.

"TiVo Announces First Advertising Search Product for Television"; press release from [www.tivo.com](http://www.tivo.com); Nov. 28, 2005.

"TiVo Begins Rollout of Online Services Now Accessible Directly on the TV"; press release from [www.tivo.com](http://www.tivo.com); Dec. 1, 2005.

"Comcast, Time Warner Cable hopeful on network DVRs"; from [www.reuters.com](http://www.reuters.com); Mar. 30, 2006.

"TiVo Launches Television's New Advertising Search Product"; press release from [www.tivo.com](http://www.tivo.com); May 8, 2006.

TiVo and Brightcove Partner to Deliver Broadband Content to TiVo Subscribers; press release from [www.tivo.com](http://www.tivo.com); May 10, 2006.

"TiVo Debuts New Lexus Car Configuration Application"; press release from [www.tivo.com](http://www.tivo.com); May 11, 2006.

Newcomb, Kevin; "BMW Uses TiVo Technology to Improve Product Placement"; from [www.clickz.com](http://www.clickz.com); Jun. 21, 2006.

Wingfield, Nick; "New TiVo Feature Lets Families Share Videos on TV Via the Web"; The Wall Street Journal Online; Nov. 14, 2006.

Kaye, Kate; "TiVo Broadens CBS Offerings, Adds Web-to-TV Services"; from [www.clickz.com](http://www.clickz.com); Nov. 15, 2006.

Grant, Peter and Marr, Merissa; "Comcast Nears Pact With Disney to Offer ABC Shows on Demand"; The Wall Street Journal Online; Nov. 21, 2006.

"TiVo to Insert Ads At End of Programs"; The Wall Street Journal Online; Nov. 28, 2006.

FAQ from Zango Ad Services; <http://adservices.zango.com>; 2007.

"NetZero and Juno's sophisticated targeting capabilities enable advertisers to hit an exact audience of qualified consumers"; from [www.unttd.com](http://www.unttd.com); 2007.

Shukla, Anuradha; "Visible World Offers 'Any Screen' Solution for Customized Video Advertising"; from [www.tmcnet.com](http://www.tmcnet.com); Feb. 6, 2007.

Tam, Pui-Wing; "TiVo, Amazon to Deliver Web Video to TV Sets"; The Wall Street Journal Online; Feb. 7, 2007.

Story, Louise; "The Web drives an advertising boom without the need for agencies"; International Herald Tribune (iht.com); Feb. 8, 2007.

Todd, Daniel; "The New World of Desktop Advertising"; DMNews.com; Mar. 28, 2007.

"Medio Systems to Launch Mobile Performance Ad Network—Search and recommendation technologies propel advancements in mobile advertising", article from Mobilestreams website, Mar. 19, 2007.

Hunt, Timothy J., "Moving Target", Financial Post, Oct. 1, 2000.

Luening E.; "Free ISP NetZero beefs up ad services"; web page at [http://www.news.com/Free-ISP-NetZero-beefs-up-ad-services/2100-1023\\_3-241067.html](http://www.news.com/Free-ISP-NetZero-beefs-up-ad-services/2100-1023_3-241067.html); Jan. 2, 2002.

Bergstein B.; "Ad-targeted System Monitors Your Interests with ISP's Help"; from website [www.siliconvalley.com](http://www.siliconvalley.com); Dec. 10, 2007.

White B.; "Watching What You See on the Web"; Wall Street Journal Online; Dec. 6, 2007.

"What's New: The Latest on Technology Deals"; from Dow Jones VentureWire; as published on Wall Street Journal Online; Oct. 22, 2007.

"DoubleClick Launches New Marketing Solutions"; from website [www.clickz.com](http://www.clickz.com); Oct. 6, 1998.

U.S. Appl. No. 11/765,433, filed Jun. 19, 2007.

U.S. Appl. No. 12/257,386, filed Oct. 23, 2008.

U.S. Appl. No. 12/823,709, filed Jun. 25, 2010.

U.S. Appl. No. 12/860,666, filed Aug. 20, 2010.

U.S. Appl. No. 12/911,601, filed Oct. 25, 2010.

U.S. Appl. No. 13/024,217, filed Feb. 9, 2011.

U.S. Appl. No. 13/115,946, filed May 25, 2011.

U.S. Appl. No. 13/115,949, filed May 25, 2011.

U.S. Appl. No. 13/115,952, filed May 25, 2011.

U.S. Appl. No. 13/170,110, filed Jun. 27, 2011.

U.S. Appl. No. 61/514,840, filed Aug. 3, 2011.

U.S. Appl. No. 11/968,117, filed Dec. 31, 2007.

U.S. Appl. No. 12/131,798, filed Jun. 2, 2008.

U.S. Appl. No. 12/536,451, filed Aug. 5, 2009.

U.S. Appl. No. 12/906,007, filed Oct. 15, 2010.

U.S. Appl. No. 12/912,726, filed Oct. 26, 2010.

U.S. Appl. No. 12/981,925, filed Dec. 30, 2010.

U.S. Appl. No. 13/097,885, filed Apr. 29, 2011.

U.S. Appl. No. 13/243,314, filed Sep. 23, 2011.

U.S. Appl. No. 13/274,242, filed Oct. 14, 2011.

U.S. Appl. No. 13/491,454, filed Jun. 7, 2012.

U.S. Appl. No. 13/566,881, filed Aug. 3, 2012.

U.S. Appl. No. 13/585,765, filed Aug. 14, 2012.

U.S. Appl. No. 13/585,779, filed Aug. 14, 2012.

U.S. Appl. No. 13/631,244, filed Sep. 28, 2012.

U.S. Appl. No. 13/725,309, filed Dec. 21, 2012.

U.S. Appl. No. 13/754,639, filed Jan. 30, 2013.

U.S. Appl. No. 13/906,211, filed May 30, 2013.

U.S. Appl. No. 61/655,951, filed Jun. 5, 2012.

\* cited by examiner

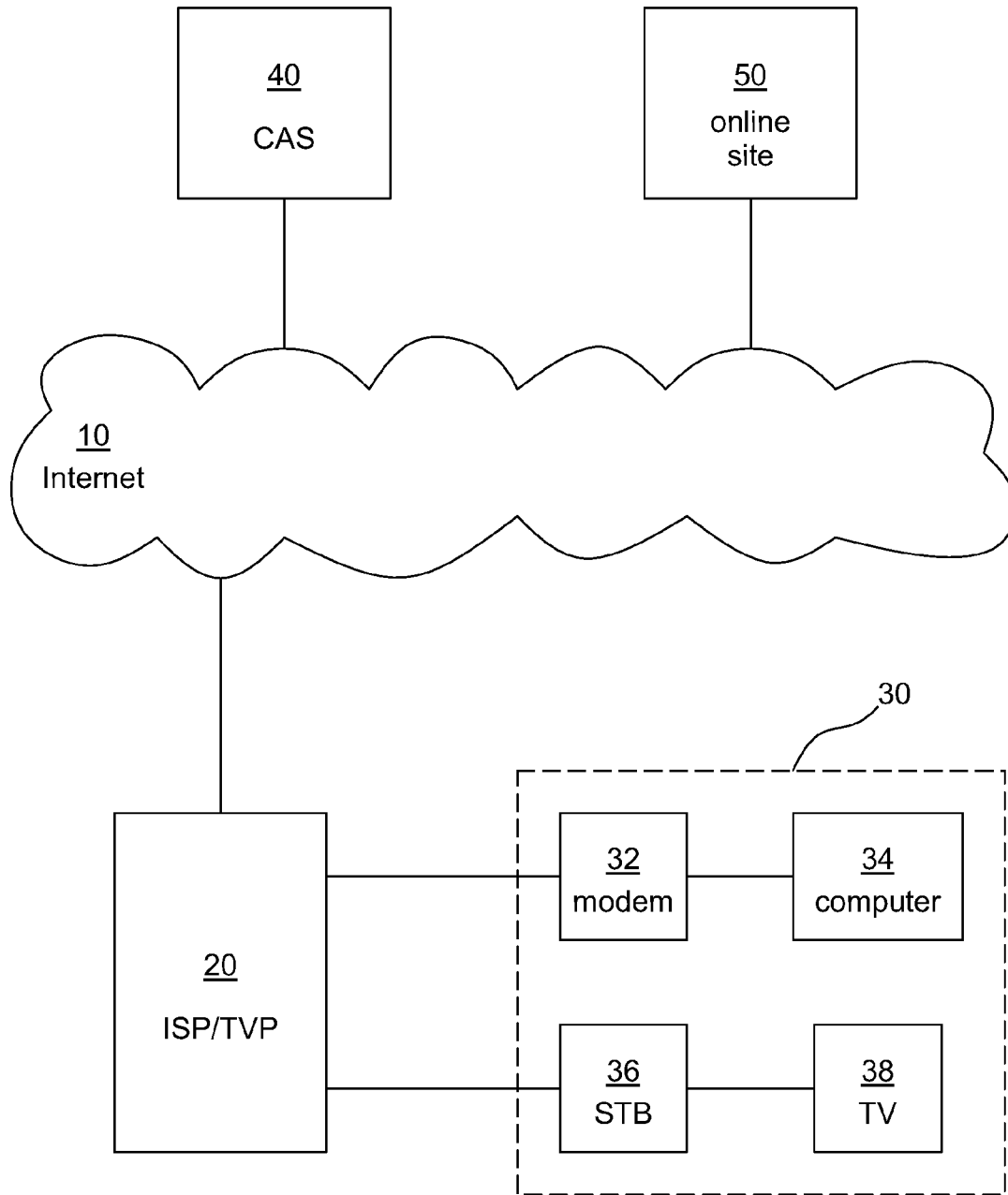

FIG. 1

# Explore Litigation Insights

Docket Alarm provides insights to develop a more informed litigation strategy and the peace of mind of knowing you're on top of things.

## Real-Time Litigation Alerts



Keep your litigation team up-to-date with **real-time alerts** and advanced team management tools built for the enterprise, all while greatly reducing PACER spend.

Our comprehensive service means we can handle Federal, State, and Administrative courts across the country.

## Advanced Docket Research



With over 230 million records, Docket Alarm's cloud-native docket research platform finds what other services can't. Coverage includes Federal, State, plus PTAB, TTAB, ITC and NLRB decisions, all in one place.

Identify arguments that have been successful in the past with full text, pinpoint searching. Link to case law cited within any court document via Fastcase.

## Analytics At Your Fingertips



Learn what happened the last time a particular judge, opposing counsel or company faced cases similar to yours.

Advanced out-of-the-box PTAB and TTAB analytics are always at your fingertips.

## API

Docket Alarm offers a powerful API (application programming interface) to developers that want to integrate case filings into their apps.

## LAW FIRMS

Build custom dashboards for your attorneys and clients with live data direct from the court.

Automate many repetitive legal tasks like conflict checks, document management, and marketing.

## FINANCIAL INSTITUTIONS

Litigation and bankruptcy checks for companies and debtors.

## E-DISCOVERY AND LEGAL VENDORS

Sync your system to PACER to automate legal marketing.