

# Exhibit 2



US007381657B2

(12) **United States Patent**  
**Zhang et al.**

(10) **Patent No.:** **US 7,381,657 B2**  
(45) **Date of Patent:** **Jun. 3, 2008**

(54) **BIASED PULSE DC REACTIVE SPUTTERING OF OXIDE FILMS**

(75) Inventors: **Hongmei Zhang**, San Jose, CA (US); **Mukundan Narasimhan**, San Jose, CA (US); **Ravi B. Mullapudi**, San Jose, CA (US); **Richard E. Demaray**, Portola Valley, CA (US)

3,616,403 A	10/1971	Collins et al. ....	204/192
3,850,604 A	11/1974	Klein .....	65/32
4,082,569 A	4/1978	Evans, Jr.	
4,111,523 A	9/1978	Kaminow et al. ....	350/96.14
4,437,966 A	3/1984	Hope et al. ....	204/298
4,587,225 A	5/1986	Tsukuma et al.	
4,619,680 A	10/1986	Nourshargh et al. ....	65/3.12
RE32,449 E	6/1987	Claussen	
4,710,940 A	12/1987	Sipes, Jr.	

(73) Assignee: **SpringWorks, LLC**, Minnetonka, MN (US)

(Continued)

(\* ) Notice: Subject to any disclaimer, the term of this patent is extended or adjusted under 35 U.S.C. 154(b) by 0 days.

FOREIGN PATENT DOCUMENTS

DE 37 38 738 C1 1/1989

(Continued)

(21) Appl. No.: **10/954,182**

(22) Filed: **Oct. 1, 2004**

OTHER PUBLICATIONS

(65) **Prior Publication Data**  
US 2005/0048802 A1 Mar. 3, 2005

Li, Ning et al., "Enhancement of aluminum oxide physical vapor deposition with a secondary plasma", Nov. 28, 2001, Scien Direct, pp. 1-11.\*

(Continued)

**Related U.S. Application Data**

(63) Continuation of application No. 10/101,863, filed on Mar. 16, 2002.

*Primary Examiner*—Michelle Estrada  
(74) *Attorney, Agent, or Firm*—Finnegan, Henderson, Farabow, Garrett & Dunner, LLP

(51) **Int. Cl.**  
*H01L 21/31* (2006.01)  
*H01L 21/469* (2006.01)

(52) **U.S. Cl.** ..... **438/769**; 438/770; 438/771; 257/E21.091; 257/E21.169; 257/E21.2; 257/E21.462; 257/E23.132

(57) **ABSTRACT**

A biased pulse DC reactor for sputtering of oxide films is presented. The biased pulse DC reactor couples pulsed DC at a particular frequency to the target through a filter which filters out the effects of a bias power applied to the substrate, protecting the pulsed DC power supply. Films deposited utilizing the reactor have controllable material properties such as the index of refraction. Optical components such as waveguide amplifiers and multiplexers can be fabricated using processes performed on a reactor according to the present invention.

(58) **Field of Classification Search** ..... 438/769, 438/770, 771, 787, 788; 257/E23.132, E21.091, 257/E21.169, E21.2, E21.462  
See application file for complete search history.

(56) **References Cited**  
U.S. PATENT DOCUMENTS  
3,309,302 A 3/1967 Heil

**21 Claims, 27 Drawing Sheets**

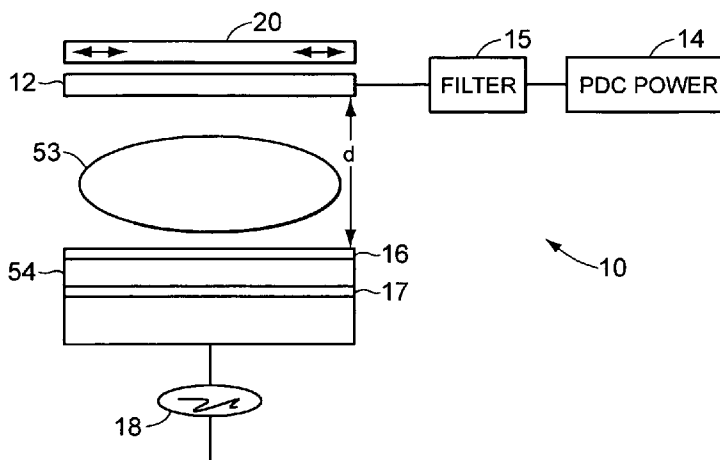

## US 7,381,657 B2

Page 2

U.S. PATENT DOCUMENTS						
			5,909,346	A	6/1999	Malhotra et al.
			5,930,046	A	7/1999	Solberg et al.
4,785,459	A	11/1988	5,930,584	A	7/1999	Sun et al.
4,915,810	A	4/1990	5,942,089	A	8/1999	Sproul et al. .... 204/192.13
4,978,437	A	12/1990	5,948,215	A	9/1999	Lantsman ..... 204/192.12
5,085,904	A	2/1992	5,952,778	A	9/1999	Haskal et al.
5,107,538	A	4/1992	5,961,682	A	10/1999	Lee et al. .... 65/384
5,119,460	A	6/1992	5,966,491	A	10/1999	DiGiovanni
5,173,271	A	12/1992	5,977,582	A	11/1999	Fleming et al. .... 257/310
5,174,876	A	12/1992	6,000,603	A	12/1999	Koskenmaki et al.
5,196,041	A	3/1993	6,001,224	A	12/1999	Drummond ..... 204/192.12
5,200,029	A	4/1993	6,004,660	A	12/1999	Topolski et al.
5,206,925	A	4/1993	6,024,844	A	2/2000	Drummond et al. ... 204/192.12
5,225,288	A	7/1993	6,045,626	A	4/2000	Yano et al.
5,237,439	A	8/1993	6,046,081	A	4/2000	Kuo
5,252,194	A	10/1993	6,051,114	A	4/2000	Yao et al. .... 204/192.3
5,287,427	A	2/1994	6,051,296	A	4/2000	McCaulley et al.
5,296,089	A	3/1994	6,052,397	A	4/2000	Jeon et al.
5,303,319	A	4/1994	6,057,557	A	5/2000	Ichikawa ..... 257/59
5,306,569	A	4/1994	6,058,233	A	5/2000	Dragone
5,309,302	A	5/1994	6,071,323	A	6/2000	Kawaguchi
5,338,625	A	8/1994	6,077,642	A	6/2000	Ogata et al.
5,355,089	A	10/1994	6,080,643	A	6/2000	Noguchi et al.
5,381,262	A	1/1995	6,088,492	A	7/2000	Kaneko et al.
5,427,669	A	6/1995	6,093,944	A	7/2000	VanDover ..... 257/310
5,435,826	A	7/1995	6,106,933	A	8/2000	Nagai et al.
5,457,569	A	10/1995	6,117,279	A	9/2000	Smolanoff et al. .... 204/192.12
5,472,795	A	12/1995	6,133,670	A	10/2000	Rodgers et al.
5,475,528	A	12/1995	6,146,225	A	11/2000	Sheats et al.
5,478,456	A	12/1995	6,154,582	A	11/2000	Bazylenko et al.
5,483,613	A	1/1996	6,157,765	A	12/2000	Bruce et al.
5,499,207	A	3/1996	6,162,709	A	12/2000	Raux et al. .... 438/513
5,512,147	A	4/1996	6,165,566	A	12/2000	Tropsha
5,538,796	A	7/1996	6,168,884	B1	1/2001	Neudecker et al.
5,555,127	A	9/1996	6,176,986	B1	1/2001	Watanabe et al. .... 204/298.13
5,561,004	A	10/1996	6,197,167	B1	3/2001	Tanaka
5,563,979	A	10/1996	6,198,217	B1	3/2001	Suzuki et al.
5,565,071	A	10/1996	6,204,111	B1	3/2001	Uemoto et al.
5,569,520	A	10/1996	6,210,544	B1	4/2001	Sasaki
5,591,520	A	1/1997	6,214,660	B1	4/2001	Uemoto et al.
5,597,660	A	1/1997	6,232,242	B1	5/2001	Hata et al.
5,603,816	A	2/1997	6,236,793	B1	5/2001	Lawrence et al.
5,607,560	A	3/1997	6,242,129	B1	6/2001	Johnson
5,607,789	A	3/1997	6,242,132	B1	6/2001	Neudecker et al.
5,612,152	A	3/1997	6,248,291	B1	6/2001	Nakagama et al. .... 419/46
5,613,995	A	3/1997	6,248,640	B1	6/2001	Nam
5,645,626	A	7/1997	6,261,917	B1	7/2001	Quek et al.
5,654,054	A	8/1997	6,280,585	B1	8/2001	Obinata et al. .... 204/298.19
5,654,984	A	8/1997	6,280,875	B1	8/2001	Kwak et al.
5,686,360	A	11/1997	6,281,142	B1	8/2001	Basceri et al. .... 438/771
5,689,522	A	11/1997	6,287,986	B1	9/2001	Mihara ..... 438/763
5,693,956	A	12/1997	6,288,835	B1	9/2001	Nilsson et al.
5,702,829	A	12/1997	6,290,821	B1	9/2001	McLeod
5,718,813	A	2/1998	6,290,822	B1	9/2001	Fleming et al. .... 204/192.22
5,719,976	A	2/1998	6,300,215	B1	10/2001	Shin
5,731,661	A	3/1998	6,302,939	B1	10/2001	Rabin et al.
5,738,731	A	4/1998	6,306,265	B1	10/2001	Fu et al.
5,755,938	A	5/1998	6,344,419	B1	2/2002	Forster et al. .... 438/758
5,757,126	A	5/1998	6,350,353	B2	2/2002	Gopalraja et al. .... 204/192.3
5,762,768	A	6/1998	6,356,694	B1	3/2002	Weber
5,771,562	A	6/1998	6,358,810	B1	3/2002	Dornfest et al. .... 438/396
5,792,550	A	8/1998	6,361,662	B1	3/2002	Chiba et al. .... 204/192.2
5,811,177	A	9/1998	6,365,300	B1	4/2002	Ota et al.
5,830,330	A	11/1998	6,365,319	B1	4/2002	Heath et al.
5,831,262	A	11/1998	6,376,027	B1	4/2002	Lee et al.
5,841,931	A	11/1998	6,391,166	B1	5/2002	Wang
5,847,865	A	12/1998	6,409,965	B1	6/2002	Nagata et al. .... 419/26
5,849,163	A	12/1998	6,413,382	B1	7/2002	Wang et al. .... 204/192.12
5,853,830	A	12/1998	6,413,645	B1	7/2002	Graff et al.
5,855,744	A	1/1999	6,416,598	B1	7/2002	Sircar
5,870,273	A	2/1999	6,423,776	B1	7/2002	Akkapeddi et al.

## US 7,381,657 B2

Page 3

6,452,717 B1 9/2002 Endo  
6,488,822 B1 12/2002 Moslehi ..... 204/192.12  
6,506,289 B2 1/2003 Demaray et al.  
6,511,615 B1 1/2003 Dawes et al. .... 264/1.21  
6,533,907 B2 3/2003 Demaray et al.  
6,537,428 B1 3/2003 Xiong et al. .... 204/192.13  
6,563,998 B1 5/2003 Farah et al. .... 385/131  
6,576,546 B2 6/2003 Gilbert et al.  
6,602,338 B2 8/2003 Chen et al. .... 252/301.4  
6,605,228 B1 8/2003 Kawaguchi et al. .... 216/24  
6,615,614 B1 9/2003 Makikawa et al. .... 65/386  
6,632,563 B1 10/2003 Krasnov et al.  
6,673,716 B1\* 1/2004 D'Couto et al. .... 438/656  
6,683,244 B2 1/2004 Fujimori et al.  
6,683,749 B2 1/2004 Daby et al.  
6,750,156 B2 6/2004 Le et al.  
6,760,520 B1 7/2004 Medin et al.  
6,768,855 B1 7/2004 Bakke et al.  
6,818,356 B1 11/2004 Bates  
6,827,826 B2 12/2004 Demaray et al.  
6,846,765 B2 1/2005 Imamura et al.  
6,884,327 B2 4/2005 Pan et al.  
7,262,131 B2 8/2007 Narasimhan et al.  
2001/0027159 A1 10/2001 Kaneyoshi  
2001/0031122 A1 10/2001 Lackritz et al.  
2001/0034106 A1\* 10/2001 Moise et al. .... 438/396  
2001/0041460 A1 11/2001 Wiggins  
2002/0001746 A1 1/2002 Jenson  
2002/0014406 A1 2/2002 Takashima  
2002/0033330 A1 3/2002 Demaray et al.  
2002/0076133 A1 6/2002 Li et al.  
2002/0106297 A1 8/2002 Ueno et al. .... 419/12  
2002/0115252 A1 8/2002 Haukka et al.  
2002/0134671 A1 9/2002 Demaray et al.  
2002/0140103 A1 10/2002 Kloster et al.  
2002/0170821 A1 11/2002 Sandlin et al.  
2002/0191916 A1 12/2002 Frish et al.  
2003/0019326 A1 1/2003 Han et al. .... 45/245  
2003/0022487 A1 1/2003 Yoon et al. .... 438/642  
2003/0035906 A1 2/2003 Memarian et al.  
2003/0042131 A1 3/2003 Johnson ..... 204/192.12  
2003/0044118 A1 3/2003 Zhou et al.  
2003/0063883 A1 4/2003 Demaray et al. .... 385/129  
2003/0077914 A1\* 4/2003 Le et al. .... 438/763  
2003/0079838 A1 5/2003 Breka ..... 156/345.48  
2003/0097858 A1 5/2003 Strohhofer et al.  
2003/0127319 A1 7/2003 Demaray et al.  
2003/0134054 A1 7/2003 Demaray et al.  
2003/0141186 A1 7/2003 Wang et al. .... 204/298.07  
2003/0143853 A1 7/2003 Celii et al.  
2003/0173207 A1 9/2003 Zhang et al.  
2003/0173208 A1 9/2003 Pan et al.  
2003/0174391 A1 9/2003 Pan et al.  
2003/0175142 A1\* 9/2003 Milonopoulou et al. .... 419/49  
2003/0178637 A1 9/2003 Chen et al.  
2003/0185266 A1 10/2003 Henrichs  
2004/0043557 A1 3/2004 Haukka et al.  
2004/0077161 A1\* 4/2004 Chen et al. .... 438/622  
2004/0105644 A1 6/2004 Dawes  
2004/0259305 A1 12/2004 Demaray et al.  
2005/0000794 A1 1/2005 Demaray et al.  
2005/0006768 A1 1/2005 Narasimhan et al.  
2005/0175287 A1 8/2005 Pan et al.  
2005/0183946 A1 8/2005 Pan et al.  
2006/0054496 A1 3/2006 Zhang et al.  
2006/0057283 A1 3/2006 Zhang et al.  
2006/0057304 A1 3/2006 Zhang et al.

2007/0053139 A1 3/2007 Zhang et al.

## FOREIGN PATENT DOCUMENTS

EP 0 510 883 A2 10/1992  
EP 0 652 308 A2 10/1994  
EP 0 639 655 A1 2/1995  
EP 0 820 088 1/1998  
EP 0 867 985 A1 9/1998  
EP 1068899 A1 1/2001  
EP 1 092 689 A1 4/2001  
EP 1 189 080 A2 3/2002  
JP 2-054764 A2 2/1990  
JP 5-230642 A 9/1993  
JP 6-010127 1/1994  
JP 6-100333 12/1994  
JP 7-224379 A 8/1995  
JP 7-233469 9/1995  
KR 2002-26187 4/2002  
WO WO 96/23085 8/1996  
WO WO 97/35044 9/1997  
WO WO 99/61674 A1 12/1999  
WO WO 00/21898 A1 4/2000  
WO WO 00/22742 4/2000  
WO WO 00/36665 6/2000  
WO WO 01/82297 A1 11/2001  
WO WO 02/12932 2/2002  
WO WO 2004/021532 A1 3/2004  
WO WO 2004/077519 A2 9/2004  
WO WO 2004/106581 A2 12/2004  
WO WO 2004/106582 A2 12/2004  
WO WO 2006/063308 A2 6/2006  
WO WO 2007/027535 A2 3/2007

## OTHER PUBLICATIONS

Barbier, Denis, "Performances and potential applications of erbium doped planar waveguide amplifiers and lasers," *GeeO*, pp. 58-63.  
Belkind et al., "Using pulsed direct current power for reactive sputtering of Al<sub>2</sub>O<sub>3</sub>," *J. Vac. Sci. Technol.* A 17(4), pp. 1934-1940 (Jul. 1999).  
Byer et al., "Nonlinear Optics and Solid-state Lasers," *IEEE Journal on Selected Topics in Quantum Electronics*, vol. 6, No. 6, pp. 921-929 (Nov. 2000).  
Fujii et al., "1.54 mm photoluminescence of Er<sup>3+</sup> doped into SiO<sub>2</sub> films containing Si nanocrystals: Evidence for energy transfer from Si nanocrystals for Er<sup>3+</sup>," *Appl. Phys. Lett.*, 71 (9), pp. 1198-1200 (Sep. 1997).  
Kelly et al., "Reactive pulsed magnetron sputtering process for alumina films," *J. Vac. Sci. Technol.* A 18(6), pp. 2890-2896 (Nov. 2000).  
Kelly et al., "Control of the structure and properties of aluminum oxide coatings deposited by pulsed magnetron sputtering," *J. Vac. Sci. Technol.* A 17(3), pp. 945-953 (May 1999).  
Pan et al., "Planar Er<sup>3+</sup>-doped aluminosilicate waveguide amplifier with more than 10 dB gain across C-band," *Optical Society of America*, 3 pages (2000).  
Roberts et al., "The Photoluminescence of Erbium-doped Silicon Monoxide," Department of Electronics and Computer Science, 7 pages (Jun. 1996).  
Schiller et al., "PVD Coating of Plastic Webs and Sheets with High Rates on Large Areas," European Materials Research Society 1999 Spring Meeting, Strasbourg, France (Jun. 1-4, 1999).  
Shaw et al., "Use of Vapor Deposited Acrlate Coatings to Improve the Barrier Properties of MetallizedFilm," Society of Vacuum Coaters 505/856-7168, 37th Annual Technical Conference Proceedings, pp. 240-244 (1994).  
Shin et al., "Dielectric and Electrical Properties of Sputter Grown (Ba,Sr)TiO<sub>3</sub> Thin Films," *J. Appl. Phys.*, vol. 86, No. 1, pp. 506-513, (Jul. 1, 1999).

## US 7,381,657 B2

Page 4

- Ting et al., "Study of planarized sputter-deposited SiO<sub>2</sub>," *J. Vac. Sci. Technol.*, 15(3) pp. 1105-1112 (May/June 1978).
- Van Dover, R.B. "Amorphous Lanthanide-Doped TiO<sub>2</sub> Dielectric Films," *Appl. Phys. Lett.*, vol. 74, No. 20, pp. 3041-3043 (May 17, 1999).
- Westlinder et al. "Simulation and Dielectric Characterization of Reactive dc Magnetron Cosputtered (Ta<sub>2</sub>O<sub>5</sub>)<sub>1-x</sub> Thin Films," *J. Vac. Sci. Technol. B*, vol. 20, No. 3, pp. 855-861 (May/June 2002).
- Yoshikawa, K. et al., "Spray formed aluminium alloys for sputtering targets," *Power Metallurgy*, vol. 43, No. 3, pp. 198-199 (2000).
- Zhang, Hongmei et al. "High Dielectric Strength, High k TiO<sub>2</sub> Films by Pulsed DC, Reactive Sputter Deposition," (2002).
- Crowder, et al., "Low-Temperature Single-Crystal Si TFT's Fabricated on Si Films Processed via Sequential Lateral Solidification," *IEEE*, vol. 19, No. 8 (Aug. 1998), pp. 306-308.
- Greene et al., "Morphological and electrical properties of rf sputtered Y2O<sub>3</sub>-doped ZnO thin films," *J. Vac. Sci. Technol.*, vol. 13, No. 1 (Jan./Feb. 1976), pp. 72-75.
- Hwang, Man-Soo et al., "The effect of pulsed magnetron sputtering on the properties of indium thin oxide thin films," Elsevier Science B.V., p. 29-33, (2003).
- Im, et al. "Controlled Super-lateral Growth of Si Films for Microstructural Manipulation and Optimization," *Materials Science Program* (1998), pp. 603-617.
- Im, et al., "Crystalline Si Films for Integrated Active-Matrix LiquidCrystal Displays," *MrS Bulletin* (Mar. 1996), pp. 39-48.
- Im, et al., "Single-crystal Si films for thin-film transistor devices," *American Institute of Physics* (1997), pp. 3434-3436.
- Tukamoto, H. et al., "Electronic Conductivity of LiCoO<sub>8</sub> and Its Enhancement by Magnesium Doping," *J. Electrochem. Soc.*, vol. 44, No. 9, pp. 3164-3168 (Sep. 1997).
- Response to Office Action filed on Mar. 14, 2005 in U.S. Appl. No. 10/291,179.
- Office Action issued on Jun. 15, 2005 in U.S. Appl. No. 10/291,179.
- Office Action issued on Mar. 17, 2005 in U.S. Appl. No. 09/903,081.
- Response to Office Action filed on Jun. 17, 2005 in U.S. Appl. 09/903,081.
- Office Action issued on Jul. 8, 2005 in U.S. Appl. No. 09/903,081.
- Office Action dated Jan. 13, 2005, received in U.S. Appl. No. 10/101,863.
- Response to office Action filed on Jun. 10, 2005 in U.S. Appl. No. 10/101,863.
- Office Action issued on Mar. 14, 2005 in U.S. Appl. No. 10/789,953.
- Office Action issued Mar. 24, 2005 in U.S. Appl. No. 10/851,542.
- Dorey, R.A., "Low temperature micromoulding of functional ceramic devices," Grant summary for GR/S84156/01 for the UK Engineering and Physical Sciences Research Council, 2 pages (2004).
- Howson, R.P., "The reactive sputtering of oxides and nitrides," *Pure & Appl. Chem.* 66(6):1311-1318 (1994).
- Office Action issued Sep. 21, 2005 in U.S. Appl. No. 11/100,856.
- Office Action issued on Aug. 4, 2005, in U.S. Appl. 10/101,863.
- Office Action issued on Aug. 8, 2005 in U.S. Appl. No. 10/101,341.
- Office Action issued on Oct. 3, 2005 in U.S. Appl. No. 10/650,461.
- Office Action issued on Mar. 24, 2005 in U.S. Appl. No. 10/851,542.
- Response to Office Action filed Jul. 25, 2005 in U.S. Appl. No. 10/851,542.
- Office Action issued on Oct. 19, 2005 in U.S. Appl. No. 10/851,542.
- ASM Handbook*, Formerly Ninth Edition, Metals Handbook, vol. 15, Casting, Davis et al. (Eds.), ASM International, pp. 372-373, 376-383, and 410-411 (1988).
- Cocorullo, G. et al., "Amorphous silicon waveguides and light modulators for integrated photonics realized by low-temperature plasma-enhanced chemical-vapor deposition," *Optics Lett.* 21(24):2002-2004 (1996).
- Kelly, P.J. et al., "A novel technique for the deposition of aluminum-doped zinc oxide films," *Thin Solid Films* 426(1-2):111-116 (2003).
- Tomaszewski, H. et al., "Yttria-stabilized zirconia thin films grown by reactive r.f. magnetron sputtering," *Thin Solid Films* 287:104-109 (1996).
- Response to Final Office Action filed Apr. 14, 2006, in U.S. Appl. Response to Office Action filed Jul. 27, 2006, in U.S. Appl. No. 10/291,179.
- Notice of Allowance mailed Aug. 6, 2002, in US Patent 6,506,289.
- Response to Office Action filed Feb. 28, 2006 in U.S. Appl. No. 09/903,081.
- Final Office Action mailed May 8, 2006 in U.S. Appl. No. 09/903,081.
- Final Office Action mailed Jun. 9, 2006 in U.S. Appl. No. 11/100,856.
- Office Action mailed Mar. 22, 2006, in U.S. Appl. No. 10/101,863.
- Response to Office Action filed Jun. 12, 2006, in U.S. Appl. No. 10/101,863.
- Response to Office Action filed on May 15, 2006, in U.S. Appl. No. 10/101,341.
- Office Action issued on Aug. 2, 2006, in U.S. Appl. No. 10/101,341.
- Office Action issued on Mar. 23, 2006, in U.S. Appl. No. 10/650,461.
- Response to Office Action filed on Jul. 24, 2006, in U.S. Appl. No. 10/650,461.
- Response to Office Action filed Mar. 2, 2006 in U.S. Appl. No. 10/789,953.
- Final Office Action issued on May 19, 2006 in U.S. Appl. No. 10/789,953.
- Office Action from Singapore Patent Office in Appl. No. 200505388-9, dated Mar. 20, 2006.
- Office Action mailed Apr. 19, 2006 in U.S. Appl. No. 10/851,542.
- Response to Office Action filed Jul. 26, 2006 in U.S. Appl. No. 10/851,542.
- Specification as filed Sep. 2, 2005, for U.S. Appl. No. 11/218,652.
- Agrawal, G.P., in: *Fiber-Optic Communication Systems*, 2nd Edition, John Wiley & Sons, New York, pp. 362-399 and 415 (1997).
- Masuda, H. & Kawai, S., "Wide-band and gain-flattened hybrid fiber amplifier consisting of an EDFA and a multiwavelength pumped raman amplifier," *IEEE Photonics Technology Lett.* 11(6):647-649 (1999).
- Snoeks, E. et al., "Cooperative upconversion in erbium-implanted soda-lime silicate glass optical waveguides," *J. Opt. Soc. Am. B* 12(8):1468-1474 (1995).
- Final Office Action dated Oct. 12, 2006, in U.S. Appl. No. 10,291,179.
- Response to Final Office Action mailed Nov. 3, 2006, in U.S. Appl. No. 10,291,179.
- Office Action dated Dec. 1, 2006, in U.S. Appl. No. 10,291,179.
- Amendment dated Oct. 19, 2006, in U.S. Appl. No. 09/903,081.
- Notice of Allowance issued on Oct. 21, 2004, in U.S. Appl. No. 10/101,492.
- Response to Office Action filed Sep. 11, 2006 in U.S. Appl. No. 11/100,856.
- Office Action mailed Dec. 1, 2006, in U.S. Appl. No. 11/100,856.
- Office Action mailed Sep. 6, 2006, in U.S. Appl. No. 10/101,863.
- Final Office Action mailed Oct. 19, 2006, in U.S. Appl. No. 10/650,461.
- Voluntary Amendment filed Jul. 26, 2006 in TW Appl. No. 92123625.
- Response to Final Office Action filed Aug. 3, 2006, in U.S. Appl. No. 10/789,953.
- Notice of Allowance mailed Oct. 23, 2006, in U.S. Appl. No. 10/789,953.
- Office Action dated Oct. 12, 2006, for U.S. Appl. No. 11/228,805.
- Office Action dated Sep. 22, 2006 from Korean Patent Office in Appl. No. 10-2005-7016055.
- Response to Office Action mailed Nov. 8, 2006, to the Korean Patent Office in Appl. No. 10-2005-7016055.
- Response to Office Action from Singapore Patent Office in Appl. No. 200505388-9, dated Aug. 11, 2006.
- Final Office Action dated Oct. 26, 2006, in U.S. Appl. No. 10/851,542.
- Preliminary Amendment filed Jul. 21, 2006, in U.S. Appl. No. 11/297,057.
- Supplemental Preliminary Amendment, Substitute Specification,

# Explore Litigation Insights

Docket Alarm provides insights to develop a more informed litigation strategy and the peace of mind of knowing you're on top of things.

## Real-Time Litigation Alerts



Keep your litigation team up-to-date with **real-time alerts** and advanced team management tools built for the enterprise, all while greatly reducing PACER spend.

Our comprehensive service means we can handle Federal, State, and Administrative courts across the country.

## Advanced Docket Research



With over 230 million records, Docket Alarm's cloud-native docket research platform finds what other services can't. Coverage includes Federal, State, plus PTAB, TTAB, ITC and NLRB decisions, all in one place.

Identify arguments that have been successful in the past with full text, pinpoint searching. Link to case law cited within any court document via Fastcase.

## Analytics At Your Fingertips



Learn what happened the last time a particular judge, opposing counsel or company faced cases similar to yours.

Advanced out-of-the-box PTAB and TTAB analytics are always at your fingertips.

## API

Docket Alarm offers a powerful API (application programming interface) to developers that want to integrate case filings into their apps.

## LAW FIRMS

Build custom dashboards for your attorneys and clients with live data direct from the court.

Automate many repetitive legal tasks like conflict checks, document management, and marketing.

## FINANCIAL INSTITUTIONS

Litigation and bankruptcy checks for companies and debtors.

## E-DISCOVERY AND LEGAL VENDORS

Sync your system to PACER to automate legal marketing.