

## **EXHIBIT 2**



US006218930C1

(12) **EX PARTE REEXAMINATION CERTIFICATE** (10326th)

**United States Patent**  
**Katzenberg et al.**

(10) **Number:** **US 6,218,930 C1**  
 (45) **Certificate Issued:** **Oct. 14, 2014**

(54) **APPARATUS AND METHOD FOR REMOTELY POWERING ACCESS EQUIPMENT OVER A 10/100 SWITCHED ETHERNET NETWORK**

(75) Inventors: **Boris Katzenberg**, Trumbull, CT (US);  
**Joseph A. Deptula**, Watertown, CT (US)

(73) Assignee: **Network-1 Security Solutions, Inc.**, Framingham, MA (US)

**Reexamination Request:**  
 No. 90/012,401, Jul. 20, 2012

**Reexamination Certificate for:**  
 Patent No.: **6,218,930**  
 Issued: **Apr. 17, 2001**  
 Appl. No.: **09/520,350**  
 Filed: **Mar. 7, 2000**

**Related U.S. Application Data**

(60) Provisional application No. 60/123,688, filed on Mar. 10, 1999.

(51) **Int. Cl.**  
**H04L 12/10** (2006.01)

(52) **U.S. Cl.**  
 USPC ..... **370/200**; 340/12.32; 340/12.37;  
 340/12.38; 379/386; 379/400

(58) **Field of Classification Search**  
 None  
 See application file for complete search history.

(56) **References Cited**

To view the complete listing of prior art documents cited during the proceeding for Reexamination Control Number 90/012,401, please refer to the USPTO's public Patent Application Information Retrieval (PAIR) system under the Display References tab.

*Primary Examiner* — Simon Ke

(57) **ABSTRACT**

Apparatus for remotely powering access equipment over a 10/100 switched Ethernet network comprises an Ethernet switch card with a phantom power supply for remote access equipment and added circuitry for automatic detection of remote equipment being connected to the network; determining whether the remote equipment is capable of accepting remote power in a non-intrusive manner; delivering the phantom power to the remote equipment over the same wire pairs that deliver the data signals, and automatically detecting if the remote equipment is removed from the network.

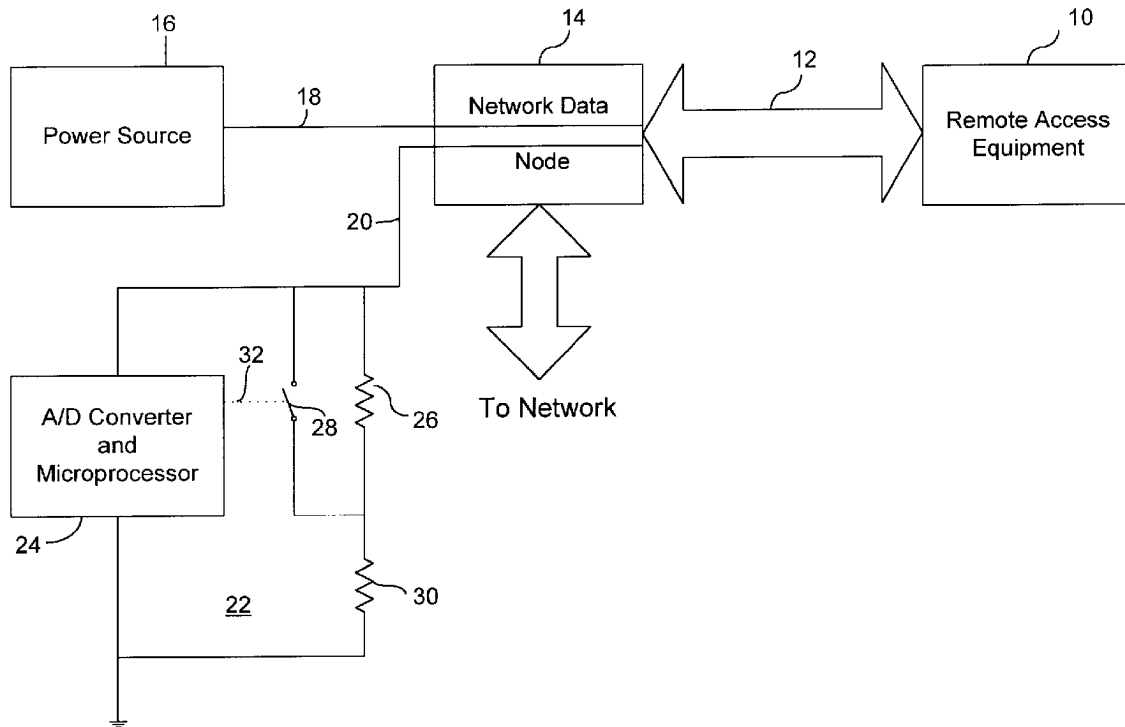

US 6,218,930 C1

**1**

**EX PARTE**  
**REEXAMINATION CERTIFICATE**  
**ISSUED UNDER 35 U.S.C. 307**

THE PATENT IS HEREBY AMENDED AS  
INDICATED BELOW.

**Matter enclosed in heavy brackets [ ] appeared in the patent, but has been deleted and is no longer a part of the patent; matter printed in italics indicates additions made to the patent.**

AS A RESULT OF REEXAMINATION, IT HAS BEEN DETERMINED THAT:

The patentability of claims **6, 8** and **9** is confirmed.

New claims **10-23** are added and determined to be patentable.

Claims **1-5** and **7** were not reexamined.

*10. Method according to claim 6, wherein said data node is an Ethernet switch.*

*11. Method according to claim 6, wherein said data signaling pair is a pair of wires used to transmit data within an Ethernet cable.*

*12. Method according to claim 6, wherein said low level current is a current used to determine whether the access device is capable of accepting remote power.*

*13. Method according to claim 6, wherein said low level current is insufficient to operate said access device, but sufficient to generate a voltage level on said data signaling pair that is used to determine whether said access device is capable of accepting remote power.*

*14. Method according to claim 6, wherein controlling power supplied by the secondary power source involves increasing the level of the low level current to a level sufficient to operate said access device.*

*15. Method according to claim 6, wherein said secondary power source is the same source of power as said main power source.*

*16. Method according to claim 6, wherein said secondary power source is the same physical device as the main power source.*

*17. Method according to claim 6, wherein said main power source provides a DC current flow.*

*18. Method according to claim 6, wherein there are at least two data signaling pairs connected between the data node and the access device.*

*19. Method according to claim 6, wherein sensing the voltage level on the data signaling pair includes at least two sensed measurements.*

*20. Method for remotely powering access equipment in an Ethernet data network, comprising,*

(a) providing

(i) an Ethernet data node adapted for data switching,

(ii) an access device adapted for data transmission,

(iii) at least one data signaling pair connected between the data node and the access device and arranged to transmit data therebetween,

(iv) a main power source connected to supply power to the data node, and

(v) a secondary power source arranged to supply power from the data node via said data signaling pair to the access device,

**2**

(c) sensing a voltage level on the data signaling pair in response to the low level current,

(d) determining whether the access device is capable of accepting remote power based on the sensed voltage level, and

(e) controlling power supplied by said secondary power source to said access device in response to a preselected condition of said voltage level.

*21. Method for remotely powering access equipment in an Ethernet data network, comprising,*

(a) providing

(i) a data node adapted for data switching,

(ii) an access device adapted for data transmission,

(iii) at least one data signaling pair connected between the data node and the access device and arranged to transmit data therebetween,

(iv) a main power source connected to supply power to the data node, and

(v) a secondary power source arranged to supply power from the data node via said data signaling pair to the access device,

(b) delivering a current from said main power source to the access device over said data signaling pair, said current being insufficient, by itself, to operate said access device connected to the data signaling pair;

(c) sensing a voltage level on the data signaling pair in response to the current, and

(d) controlling power supplied by said secondary power source to said access device in response to a preselected condition of said voltage level.

*22. Apparatus for remotely powering access equipment in a data network, comprising:*

(a) a data node adapted for data switching,

(b) an access device adapted for data transmission,

(c) at least one data signaling pair connected between the data node and the access device and arranged to transmit data therebetween,

(d) a main power source connected to supply power to the data node and deliver a low level current from said main power source to the access device over said at least one data signaling pair resulting in a voltage level on the data signaling pair that can be sensed in response to the low level current,

(e) a secondary power source arranged to supply power from the data node via said data signaling pair to the access device, wherein the power supplied by said secondary power source to the access device is controlled in response to a preselected condition of the sensed voltage level.

*23. Method for remotely powering access equipment in an Ethernet data network, comprising:*

(a) providing an access device adapted for data transmission;

(b) connecting said access device to at least one data signaling pair connected between the access device and a data node adapted for data switching, wherein said at least one data signaling pair is arranged to transmit data therebetween;

(c) receiving at said access device a low level current from a main power source over said data signaling pair, wherein said main power source is connected to supply power to the data node; and wherein a voltage level is generated on the data signaling pair in response to the low level current;

(d) producing a voltage level on the data signaling pair in

US 6,218,930 C1

3

4

*(e) receiving at said access device controlled power supplied by a secondary power source arranged to supply power from the data node via said data signaling pair to the access device, in response to a preselected condition of said voltage level.*

5

\* \* \* \* \*